



**neptronic®**

# **Steam to Steam Humidifier**

**SKS4 Series**

**Installation Instructions and User Manual**



**READ AND SAVE THESE INSTRUCTIONS**

## Safety

### Steam or Hot Water (HTHW) Supply



All work concerned with Steam or High Temperature Hot Water (HTHW) supply installation **MUST** only be performed by skilled and qualified technical personnel. The customer is always responsible for ensuring the suitability of the technical personnel.

Please observe the local regulations concerning the provision of steam and/or hot water installations.

### Electricity



All work concerned with electrical installation **MUST** only be performed by skilled and qualified technical personnel, such as an electrician or a technician with appropriate training. The customer is always responsible for ensuring the suitability of the technical personnel.

Please observe the local regulations concerning the provision of electrical installations.

## Health & Safety

Neptronic has considered the aspects of the design of their humidification systems to reduce as much as possible the risk of Legionnaires' disease and other similar conditions, but it is important that users are also aware of their responsibilities.

To prevent the growth of Legionella, users are required to:

- Avoid water temperature that favours the growth of Legionella (20-45°C).
- Avoid water stagnation.
- Clean and disinfect the humidification system.
- Have a competent person carry out a risk assessment of the water system supplying the humidifier, to ensure that the water supply is of an acceptable quality.

## Correct Use

Neptronic systems and its products are designed only for humidification use. Any other application is not considered appropriate for the intended purpose. The manufacturer cannot be made liable for any damage resulting from incorrect use.

## Access

The SKS4 electrical panel access door **MUST** never be left open, in order to avoid accidental access to live electrical parts.

## Water

Neptronic systems are designed to be used with mains, reverse osmosis, de-mineralized or partially softened water. On no account must a user attempt to introduce any other fluid or chemical into the system without first consulting Neptronic or its authorized distributor.

Water supply must not exceed the maximum pressure of 480 kPa, or the pressure limits laid out in the Installation Instructions, and must comply with local regulations.

## Foreword

### Neptronic Company Overview

Founded in 1976, we're a private corporation that designs, manufactures and distributes products for the HVAC industry. Our product line includes intelligent controllers, electronic actuators, actuated valves, humidifiers and electric heaters.

Our products are designed and manufactured by over 250 dedicated employees in our 7,500 m<sup>2</sup> (80,000 ft<sup>2</sup>) state-of-the-art facility located in Montreal, Canada. Using a vertical integration model, our entire manufacturing chain is under one roof, from software and hardware development, to SMT circuit board assembly, to sheet metal fabrication, to product testing, ensuring that our products are engineered to last.

We currently hold several national and international patents and with our continued commitment to research and development, we provide innovative products and technologies for the ever-evolving challenges of the HVAC industry. Exporting over 70% of our sales, we have an exclusive distribution network around the globe that provides comprehensive solutions to our worldwide customers.

### About the Manual

These installation and operation instructions have been developed to facilitate the installation of the SKS4 humidifier.

- The strict application of these instructions will ensure the conformity of your installation and operation as per the manufacturer's recommendations.
- The application of these instructions is one of the conditions for the application of the warranty.
- The application of these instructions does not ensure, at any time conformity to procedures, regulation or local codes, regarding electric installation and connection to local water supply.

This product has been declared conform to applicable Canadian, American and European standards.

2021<sup>©</sup>: All rights reserved. This document cannot be reproduced totally or partially by any means whether, electronic, mechanical, photocopy, recording or other, without prior written authorization of Neptronic.

### General Warranty

This product is subject to the terms and conditions described at <http://www.neptronic.com/Sales-Conditions.aspx>.



# Contents

Overview .....	5
Handling and Lifting.....	5
List of Accessories Supplied.....	6
Technical Specifications .....	6
SKS4 Nomenclature .....	6
Steam Output Capacities .....	7
Steam Output Capacities for HTHW Supply.....	8
Dimensions and Weight.....	10
Weather Proof Enclosure .....	11
Installation Overview .....	12
Installation Method Statement.....	12
Installation Steps.....	12
Step 1 - Unit Positioning and Mounting.....	13
Location .....	13
Positioning .....	14
Minimum Clearances .....	14
Ceiling Installation.....	14
Minimum Clearances - Weather Proof Enclosure .....	15
Weather Proof Enclosure Installation on Floor/Roof .....	16
Step 2 - Steam Distribution Pipe Installation.....	17
Fundamental Design Concepts .....	17
Steam Dispersion System Selection .....	18
Steam Absorption Manifold (S.A.M.E2) Horizontal Duct .....	18
Steam Absorption Manifold (S.A.M.E2) Vertical Duct .....	18
Multi-Steam System.....	18
Steam Dispersion General Recommendations .....	19
S.A.M.E2 System .....	19
Positioning the S.A.M.E2 .....	19
Placement of Steam Pipe in Horizontal Duct .....	20
Placement of Steam Pipe in Vertical Duct .....	20
Steam Pipe Work to Duct Connections with S.A.M.E2.....	21
Multi-Steam System .....	23
Selection of Multi-Steam System.....	23
Steam Pipe Work to Duct Connections with Multi-Steam.....	24
Step 3 - HTHW / Raw Steam Supply Connection.....	25
Union Dimensions and Installation .....	25
Typical Raw Steam Installation .....	25
Steam Supply Size.....	26
Raw Steam Supply and Condensate Installation .....	26
Typical HTHW Installation .....	27

HTHW Supply Size .....	27
HTHW Supply and Condensate Installation .....	27
Positioning the Control Valve .....	27
Step 4 - Water Supply Installation.....	28
Water Inlet Specifications .....	28
Water Supply Line Installation .....	28
Step 5 - Water Drain Connection .....	29
Water Drain Specifications .....	29
Water Drain Installation .....	29
Stage 6 - Electrical Supply Connections.....	30
Electrical Power Supply.....	30
Step 7 - Electrical Control Connections .....	31
Printed Circuit Board .....	31
Safety Contact Connections .....	32
Dry Contacts .....	32
Humidifier Control .....	33
Analog Signals .....	33
Humidity Control by Humidistat (External Mode).....	33
Humidity Control by Humidifier (Internal Mode).....	34
Humidity Control by External Signal .....	35
Network Communication .....	36
Controls Placement (Steam Dispersed into a Duct or AHU).....	37
Steam Actuated Valve .....	38
Controller Configuration .....	39
Control Panel Features.....	39
Idle Screen .....	40
Menu Access .....	40
Menu Navigation and Configuration .....	41
Menu - General .....	42
Menu - User Settings .....	44
Menu - Service.....	45
Menu - Installation.....	46
Menu - Integration.....	50
List of Alarms .....	53
Manual Water Level Calibration .....	55
Start-up Procedure .....	57
Initial Verification .....	57
Start-Up .....	58
Service .....	59
Cleaning the Humidifier .....	59
Strainer Maintenance .....	61
Troubleshooting .....	62



## Overview

### Handling and Lifting



Lifting or handling **MUST** be carried out by trained and qualified personnel. Ensure that the lifting operation has been properly planned, assessed for risk and that the equipment has been checked by a competent Health & Safety representative, and effective control measures are in place.

It is the customer's responsibility to ensure that the operators are trained in handling heavy goods and to enforce the relevant lifting regulations.

The SKS4 humidifier **MUST** be handled and lifted with care at all times and remain in its original packaging for as long as possible, prior to installation.

The SKS4 humidifier package may be carried using a forklift from the underside. Exercise caution before lifting to ensure that the load is balanced.

Lifting of the SKS4 humidifier **MUST** always be carried out using the appropriate Neptronic Lifting bracket. The lifting sling angle must be greater than 30° to the horizontal.

Refer to Dimensions and Weight section for system dry weights.

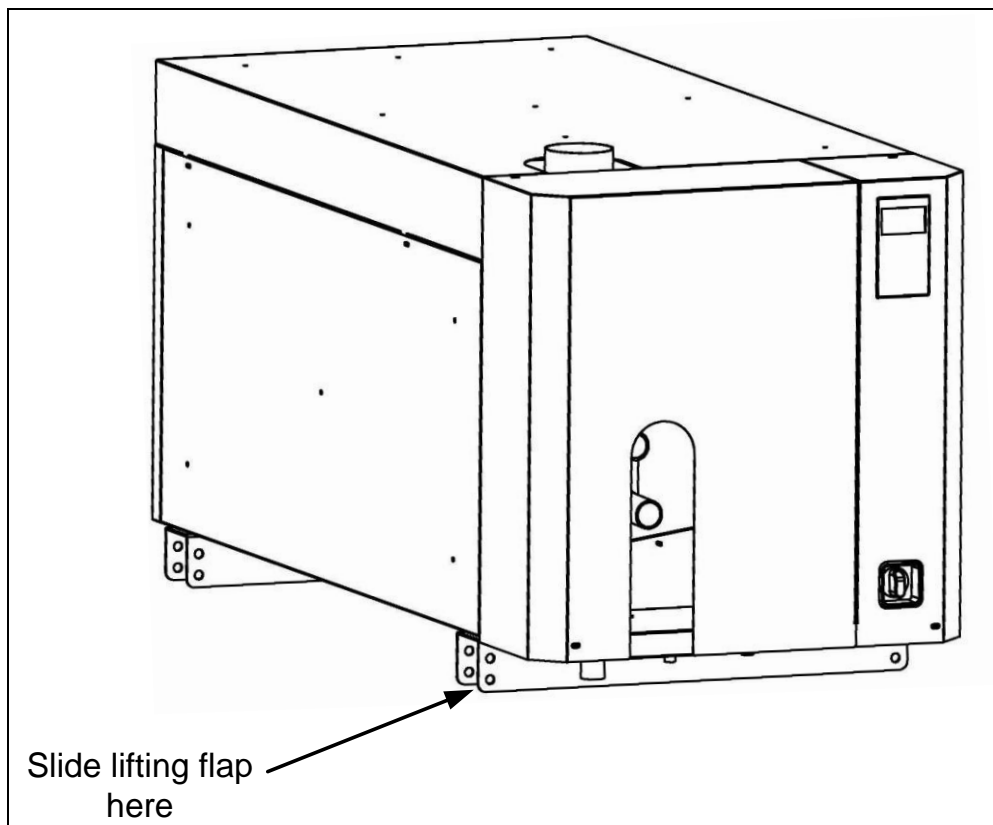

Illustration 1 - SKS4 Humidifier Lifting Bracket

### Unpacking

The SKS4 humidifier is shipped inside carton boxes or in a wooden crate. Remove packing and skids prior to commissioning.



## Steam Output Capacities

Table 1 - Stainless Steel Heat Exchanger

Model*	Nb of Heat Exc.	Output Steam Capacity (kg/h) for Supply Steam Pressure <sup>(2)</sup>					Steam Outlet Qty & Ø (mm)
		0.34 Bar (34.5kPa)	0.55 Bar (55.1kPa)	0.69 Bar (68.9kPa)	0.83 Bar (82.7kPa)	1.03 Bar (103.4kPa)	
SKS4-050-SLP	1	8	12	15	18	23	51
SKS4-100-SLP	1	15	24	30	36	45	76
SKS4-130-SLP	1	19	31	39	47	59	76
SKS4-190-SLP	1	28	46	57	69	86	76
SKS4-290-SLP	1	44	70	87	105	132	100
SKS4-390-SLP	1	59	94	118	142	177	100
SKS4-500-SLP	1	76	121	151	182	230	125
SKS4-690-SLP	1	104	167	209	251	314	125
SKS4-950-SLP	1	144	230	287	345	432	(2x) 100
SKS4-1250-SLP	2	189	303	378	454	568	(2x) 125

Table 2 - Copper Heat Exchanger

Model*	Nb of Heat Exc.	Output Steam Capacity (kg/h) for HTHW Pressure <sup>(2)</sup>							Steam Outlet Qty & Ø (mm)
		116°C	121°C	127°C	138°C	149°C	160°C	170°C	
		0.69 Bar (69kPa)	1.03 Bar (103kPa)	1.37 Bar (137kPa)	2.41 Bar (241kPa)	3.44 Bar (344kPa)	5.17 Bar (517kPa)	6.89 Bar (689kPa)	
SKS4-333-CHP	1	29	50	66	116	166	249	333	(2x) 100
SKS4-667-CHP	2	59	100	132	231	331	499	667	(2x) 125



Note: (\*) In-between capacity models are available upon request to factory.

1 - Power supply is 230Vac, 0.75A (50Hz).

2 - Raw steam or HTHW pressure at actual point of connection to humidifier.

3 - Maximum static duct pressure is 1.250 kPa. For higher static duct pressures, please consult Neptronic or its authorized distributor.





### Steam Output Capacities for HTHW Supply

Table 3 - HTHW Supply Flow, Output Capacity and Pressure Drop

Model	Flow		Output Steam Capacity (Kg/hr) for HTHW Peak Temperature and Pressure						Pressure Drop (kPa)	
			122°C	130°C	140°C	150°C	160°C	170°C		
	l/min	GPM	1.03 Bar	1.65 Bar	2.50 Bar	3.44 Bar	5.17 Bar	6.89 Bar		
103kPa			165kPa	250kPa	344kPa	517kPa	689kPa			
SKS4-333-CHP	272.4	60							287	2000
	181.6	40	49	64	108	144	198	264	1000	
	113.5	25	46	63	101	133	174	238	450	
	104.4	23	45	62	100	131	171	234	350	
	90.8	20	44	61	98	127	166	222	250	
	77.2	17	43	61	94	122	160	208	150	
	68.1	15	41	60	90	118	154	198	120	
	54.5	12	38	59	85	112	144	180	90	
	45.4	10	35	56	80	107	135	166	60	
	36.3	8	33	53	72	100	122	150	35	
	22.7	5	27	44	60	78	102	117	12	
13.6	3	21	35	54	68	88	90	-		
SKS4-667-CHP	544.8	120							574	2000
	363.2	80	98	128	216	288	396	528	1000	
	227.0	50	92	126	202	266	348	476	450	
	208.8	46	90	124	200	262	342	468	350	
	181.6	40	88	122	196	254	332	444	250	
	154.4	34	86	122	188	244	320	416	150	
	136.2	30	82	120	180	236	308	396	120	
	109.0	24	76	118	170	224	288	360	90	
	90.8	20	70	112	160	214	270	332	60	
	72.6	16	66	106	144	200	244	300	35	
	45.4	10	54	88	120	156	204	234	12	
27.2	6	42	70	108	136	176	180	-		

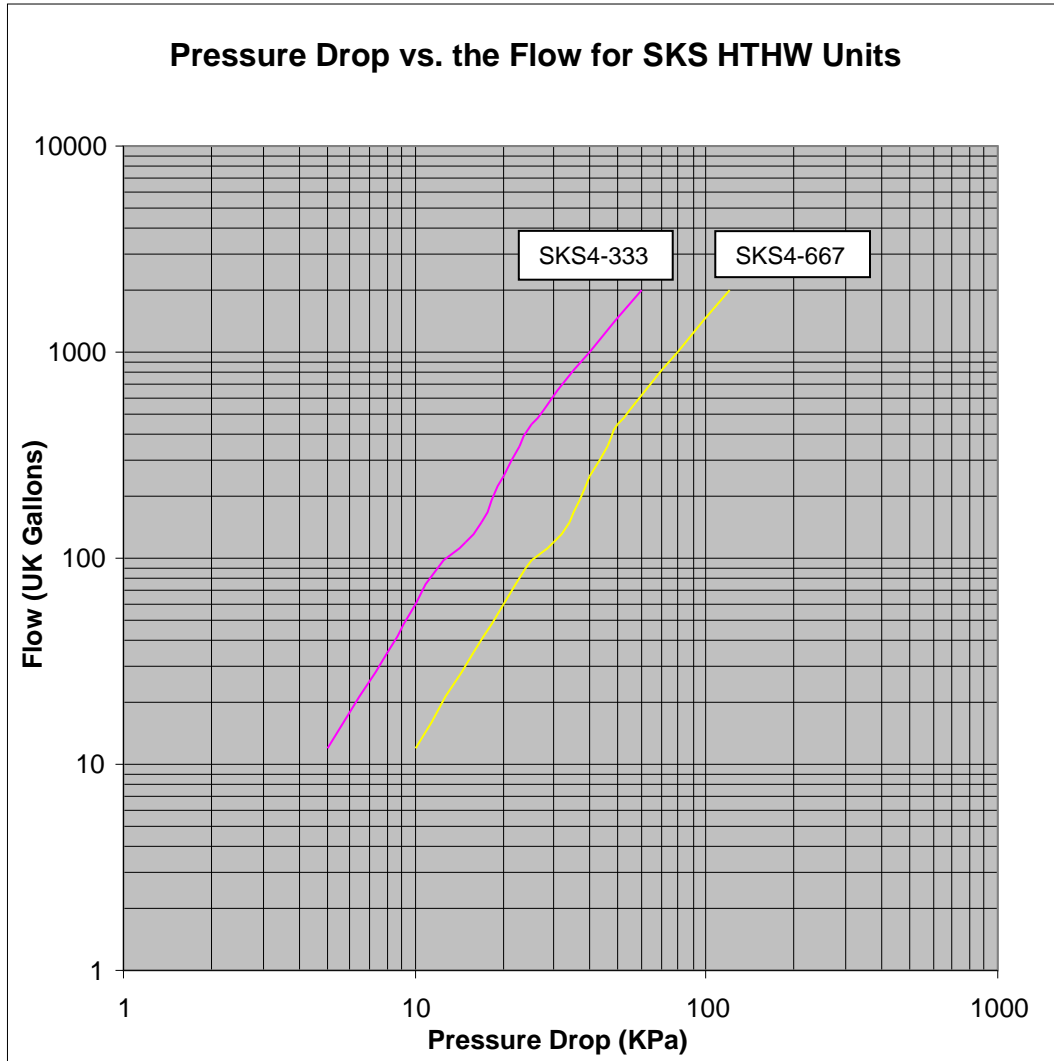

Illustration 3 - SKS4 HTHW Pressure Drop vs. Flow

- SKS4-333-CHP capacity up to 287 kg/hr, depending on flow, peak temperature and pressure drop.
- SKS4-667-CHP capacity up to 574 kg/hr, depending on flow, peak temperature and pressure drop.



## Dimensions and Weight

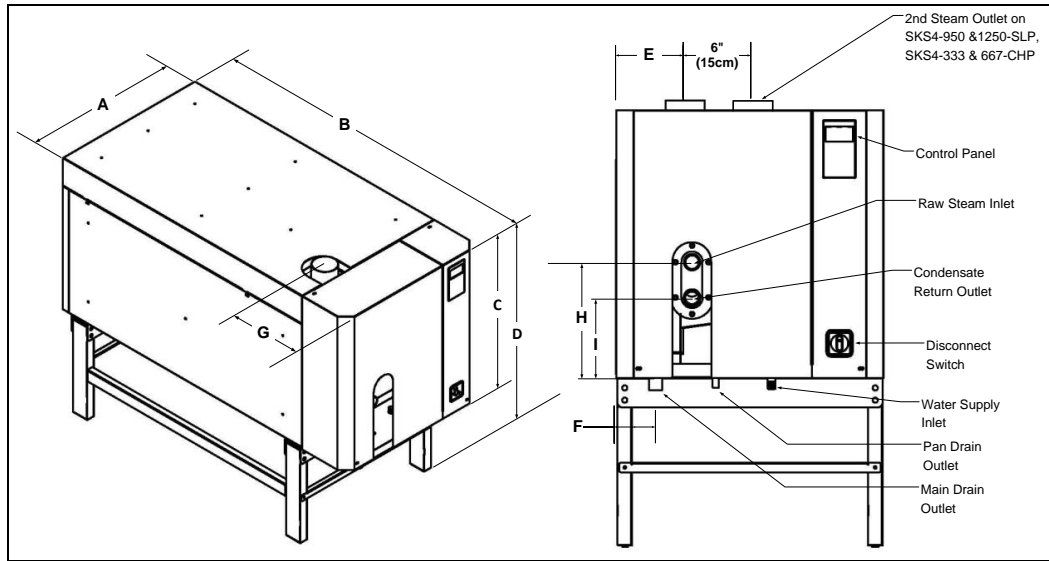

Illustration 4 - SKS4 Humidifier Dimensions

Table 4 - Dimensions and Weight (Stainless Steel Heat Exchanger)

Model	Dimensions (cm)								Weight (kg)		
	A	B	C	D	E	F	G	1 <sup>st</sup> Heat Exc.	2 <sup>nd</sup> Heat Exc.	Empty	In Operation
								H <sub>1</sub>	H <sub>2</sub>		
								I <sub>1</sub>	I <sub>2</sub>		
SKS4-050-SLP	50.3	116.3	66.5	110.5	18.1	6.0	29.8	34.0 27.2	-	116	207
SKS4-100-SLP	50.3	116.3	66.5	110.5	18.1	6.0	29.8	26.9 20.1	-	120	221
SKS4-130-SLP	50.3	116.3	66.5	110.5	18.1	6.0	29.8	26.9 20.1	-	122	220
SKS4-190-SLP	58.2	116.2	74.7	118.8	18.1	5.8	29.0	27.9 20.0	-	141	263
SKS4-290-SLP	58.2	116.2	74.7	118.8	18.1	5.8	29.0	27.9 20.0	-	143	280
SKS4-390-SLP	70.0	148.9	69.3	113.3	18.2	10.5	30.2	29.7 20.3	-	179	376
SKS4-500-SLP	70.0	148.9	69.3	113.3	18.2	10.5	30.2	29.7 20.3	-	182	373
SKS4-690-SLP	78.5	148.9	87.1	131.2	20.6	10.6	30.2	33.5 24.1	-	213	501
SKS4-950-SLP	78.5	148.9	87.1	131.2	16.8	10.6	30.2	33.5 24.3	-	215	531
SKS4-1250-SLP	78.5	148.9	108.0	152.1	16.8	10.5	30.2	31.4 22.2	60.8 51.9	259	715

Table 5 - Dimensions and Weight (Copper Heat Exchanger)

Model	Dimensions (cm)								Weight (kg)		
	A	B	C	D	E	F	G	1 <sup>st</sup> Heat Exc.	2 <sup>nd</sup> Heat Exc.	Empty	In Operation
								H <sub>1</sub>	H <sub>2</sub>		
								I <sub>1</sub>	I <sub>2</sub>		
SKS4-333-CHP	70.0	148.9	69.3	113.3	15.5	10.5	29.8	33.9 20.0	-	118	355
SKS4-667-CHP	78.5	148.9	108.0	152.1	16.8	10.6	30.2	35.6 21.6	61.7 47.7	158	485



## Weather Proof Enclosure

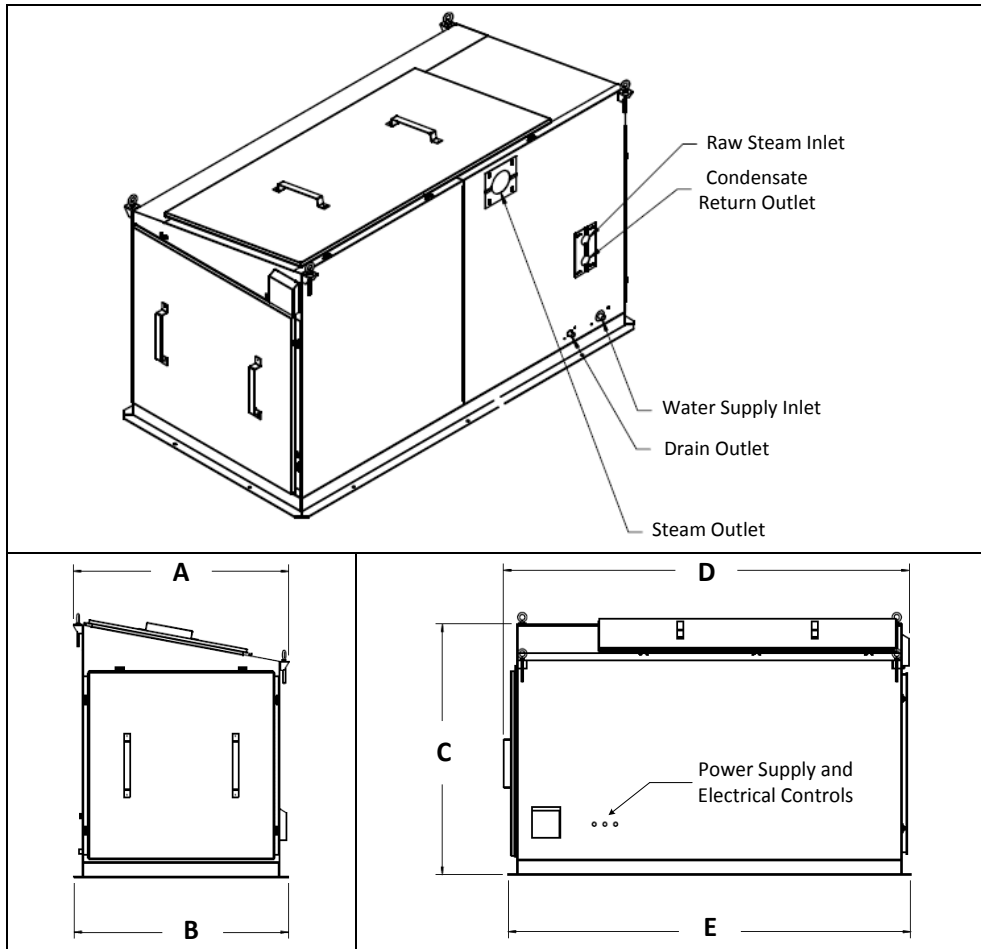

Illustration 5 - Weather Proof Enclosure Dimensions

Table 6 - Weather Proof Enclosure Dimensions and Weight (Stainless Steel Heat Exchanger)

Model	Dimensions (cm)					Weight (kg)	
	A	B	C	D	E	Empty	In Operation
SKS4-050-SLP	117.2	116.6	130.9	216.5	214.9	252	343
SKS4-100-SLP						256	357
SKS4-130-SLP						258	356
SKS4-190-SLP						277	399
SKS4-290-SLP						279	416
SKS4-390-SLP						315	512
SKS4-500-SLP	127.5	127	184.2	216.5	214.9	318	509
SKS4-690-SLP						394	682
SKS4-950-SLP						396	712
SKS4-1250-SLP						440	896

Table 7 - Weather Proof Enclosure Dimensions and Weight (Copper Heat Exchanger)

Model	Dimensions (cm)					Weight (kg)	
	A	B	C	D	E	Empty	In Operation
SKS4-333-CHP	117.2	116.6	130.9	216.5	214.9	254	491
SKS4-667-CHP	127.5	127	184.2	216.5	214.9	339	666



# Installation Overview

## Installation Method Statement



**WARNING: Risk of electric shock. Disconnect the appliance from electric supply before commencing installation.**



*Note: All installation work must conform to local codes and regulations.*

All work related to the installation of the SKS4 humidifier **MUST** only be performed by skilled and qualified technical personnel (e.g. electricians, plumbers or technicians with appropriate training).

The customer is responsible for ensuring their suitability.

For the installation of the SKS4 humidifier and its associated components, no special tooling is required above that of a fitter's toolkit.

## Installation Steps

Step 1: Unit Positioning and Mounting

Step 2: Steam Distribution Pipe Installation

Step 3: Raw Steam Supply Connection

Step 4: Water Supply Installation

Step 5: Water Drain Connection

Step 6: Electrical Supply Connections

Step 7: Electrical Control Connections

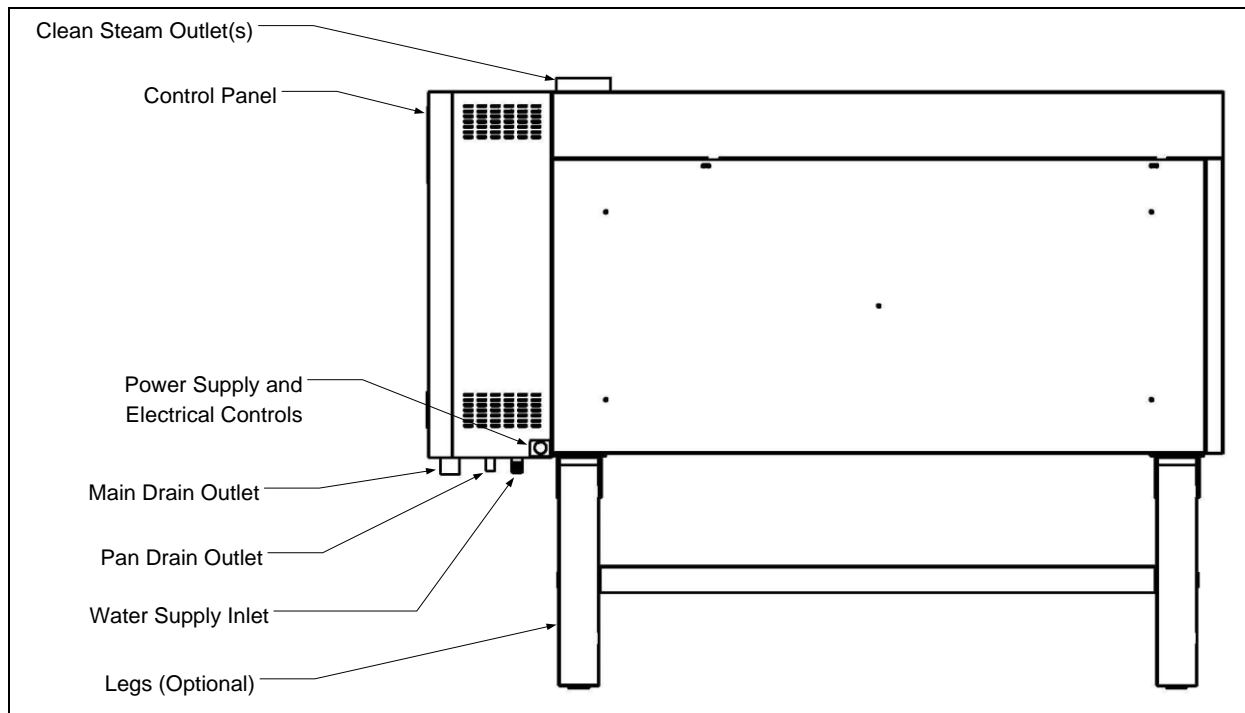

Illustration 6 - SKS4 Humidifier Overview

# Step 1 - Unit Positioning and Mounting

---

## Location



**WARNING: Failure to follow these guidelines will void the warranty.**

Consider the following points before deciding the location for the SKS4 humidifier:

- Plan a location that is easy to access and permits an easy inspection and servicing of the humidifier.
- Do not install the humidifier where failure of the appliance could cause damage to the building structure or to other expensive equipment.
- Ensure that the location is well ventilated and that the ambient temperature is less than 30°C.
- For humidifiers having the weather proof enclosure, ensure that the humidifier is installed in a location in which the outside temperature lies between -40°C and 50°C.
- Consider the total steam line length between the humidifier and the steam distributor based on the steam line material type:
  - For flexible steam hose, total steam line must not exceed 5 meters. For longer distances, use insulated hard piping.
  - For insulated hard piping, the total steam line is determined by the humidifier capacity: 0.67 m for each kg/hr capacity of the humidifier, with a maximum of 15 m. For longer steam line runs, consult factory.
- The SKS4 humidifier must be installed in a way that ensures that the steam hose length is kept to the shortest possible length.
- The SKS4 humidifier must be installed with provision for the steam supply piping connections and steam condensate trap installation.



## Positioning

- The SKS4 humidifier can be provided with adjustable legs (optional) in order to ensure proper level when installed directly on the floor. Provide a level, solid foundation for the humidifier and ensure that the floor beneath the humidifier is water proof to withstand any water spillage during servicing or in the event of a problem. Ensure that the humidifier is properly attached through its legs using anchors to the floor.
- The SKS4 humidifier must be properly levelled, in order to ensure proper return of condensate through the heat exchanger.

## Minimum Clearances

- The following minimum clearances are indicated for inspection and servicing access. The SKS4 humidifier is designed for a zero clearance to combustible materials.
- Leave a clearance of at least 1 m to the front panel and 0.6 m on the left, right and back sides of the humidifier.
- Leave a clearance of at least 0.75 m on top of the humidifier.

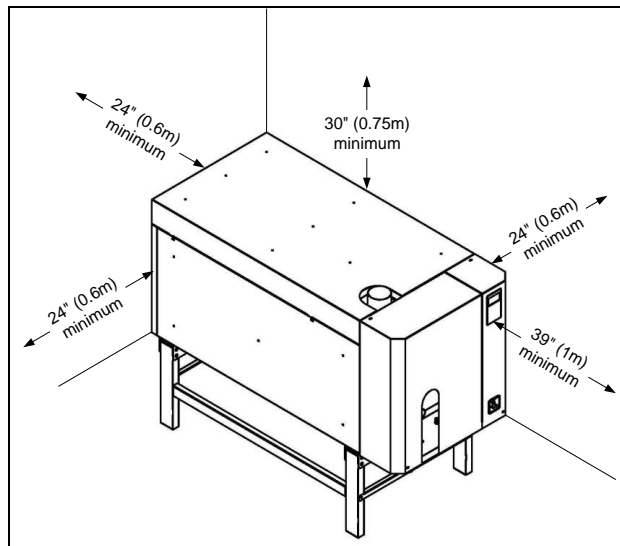

Illustration 7 - SKS4 Minimum Clearances (Floor Mounted)

## Ceiling Installation

The SKS4-050, 100 & 130-SLP models can also be hung by the ceiling using the appropriate lifting and hanging bracket. Provide the following clearances when hanging these models to the ceiling:

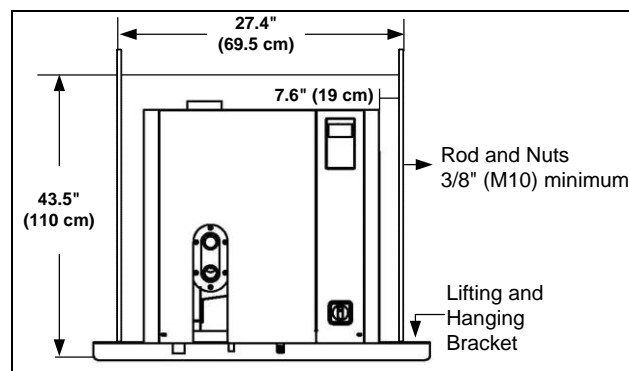

Illustration 8 - Minimum Clearances for Models SKS4-050, 100 & 130-SLP (Ceiling Mounted)



### Minimum Clearances - Weather Proof Enclosure

- The following minimum clearances are indicated for inspection and servicing access. The SKS4 humidifier is designed for a zero clearance to combustable materials.
- Leave a clearance of at least 1 m to the front panel and 0.6 m on the left, right and back sides of the humidifier.
- Leave a clearance of at least 0.75 m on top of the humidifier.

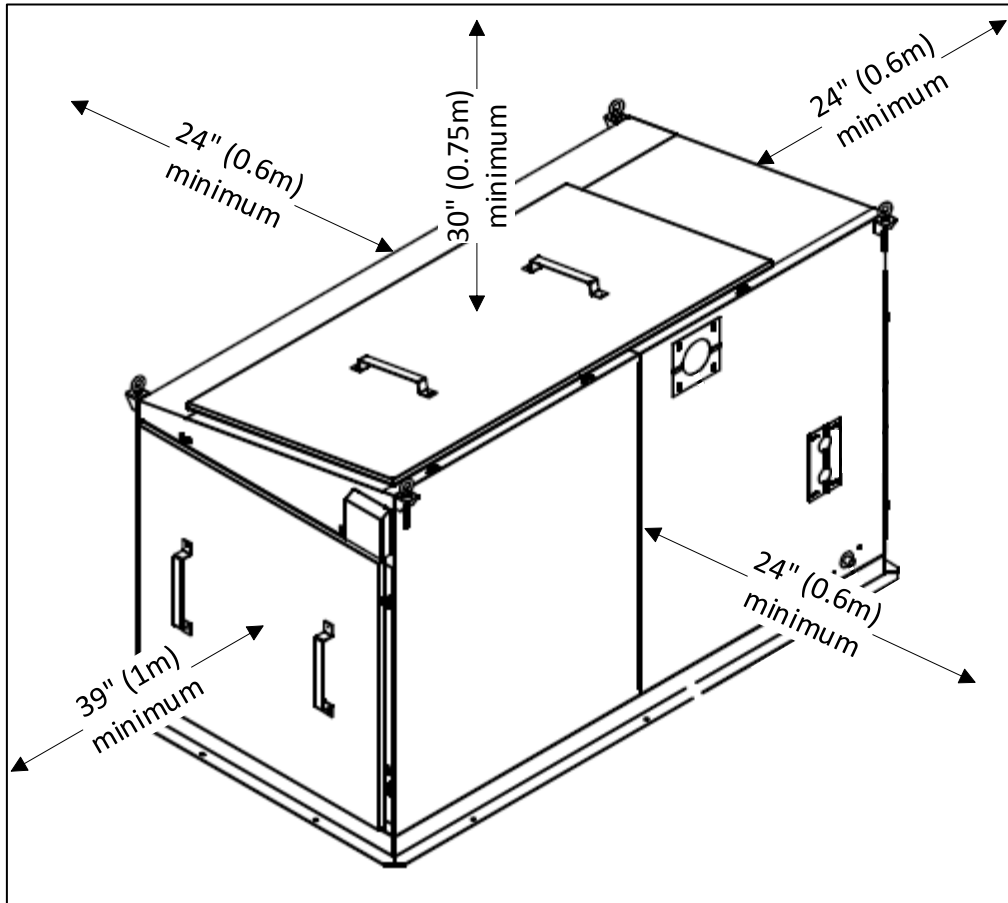

Illustration 9 - Weather Proof Enclosure Clearances





### Weather Proof Enclosure Installation on Floor/Roof

The base of the SKS4 humidifier must be secured to the floor/roof using 12mm diameter bolts and washers (not supplied). Use the provided 12mm diameter holes to secure the SKS4 humidifier to the floor/roof.

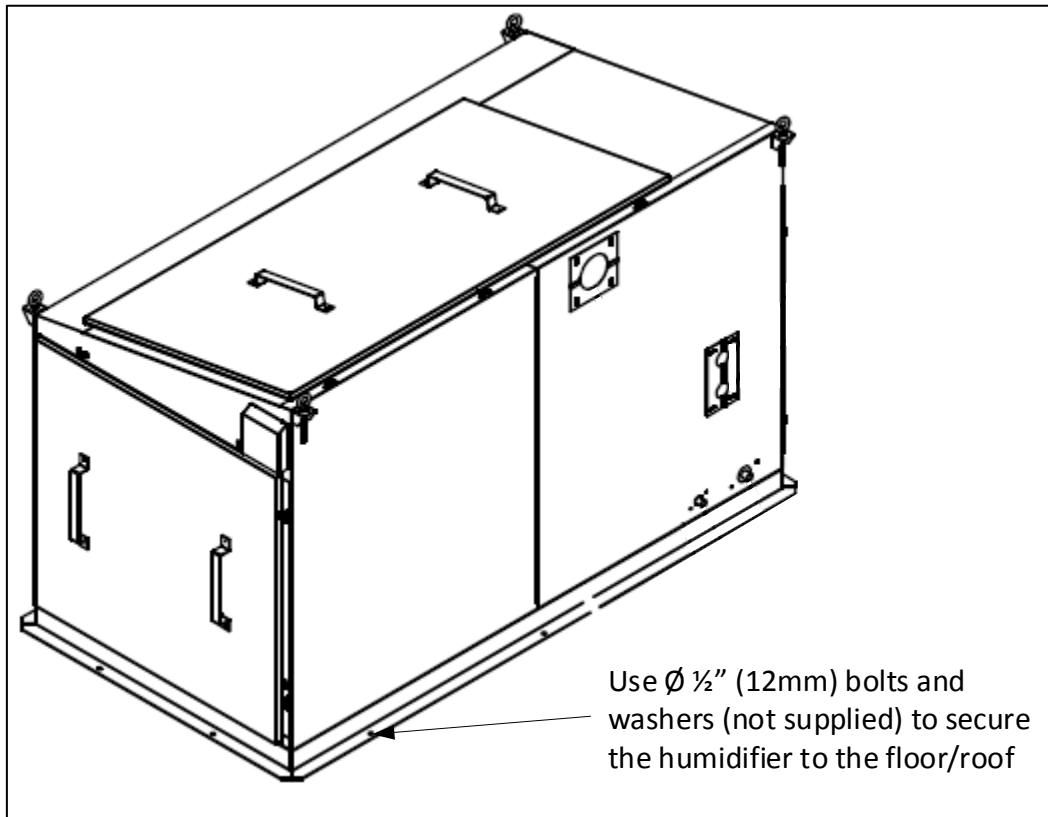

Illustration 10 - Floor/Roof Installation



## Step 2 - Steam Distribution Pipe Installation

### Fundamental Design Concepts

Follow these general installation rules in order to avoid any restrictions inside the distribution pipes and the humidifier, as well as condensation accumulation, which can lead to severe water accumulation in the duct or a humidifier malfunction.



**CAUTION: Risk of malfunction. Avoid kinks, sags and areas where condensate can be trapped.**

- The minimum steam pipe gradient must be  $7^\circ$ , i.e. 125mm rise in 1m run.
- The total length of flexible steam hoses must not exceed 5 m. For insulated rigid piping, it must not exceed 15 m.
- The lowest point of any steam hose or rigid pipe must be the humidifier. If the humidifier cannot be the lowest point of the piping, install one or more steam traps (S Type) at the lowest point(s) of the steam supply piping. The steam separator (S trap) must be installed higher than the static pressure of the system by at least 51 mm.
- Use rigid copper piping whenever possible. Flexible steam hoses can be used for short runs (up to 5 m) or for interconnecting between rigid pipe runs. Ensure that there are no kinks and that the hose does not sag when using flexible tubing. Do not use flexible hoses for curved portions of the steam line.
- When using rigid copper pipe, insulation must be used to diminish condensation build up.

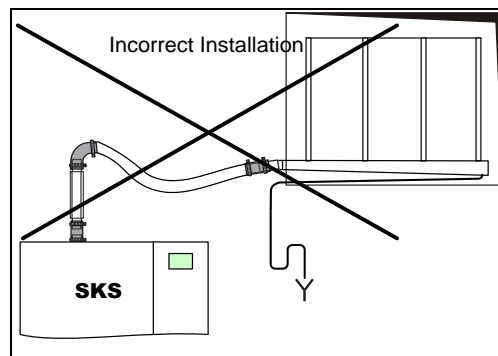

Illustration 11 - Steam Distribution Pipes: Incorrect Installation

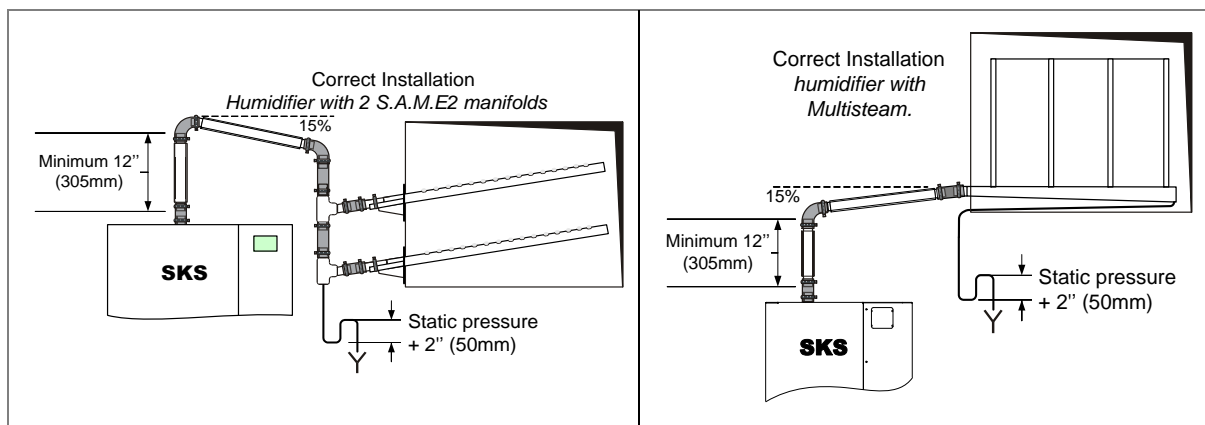

Illustration 12 - Steam Distribution Pipes: Correct Installation



## Steam Dispersion System Selection

In order to prevent the accumulation of condensation in air ducts, Neptronic has designed three basic configurations of steam distribution systems to provide the most economical solution for any particular application.

### Steam Absorption Manifold (S.A.M.E2) Horizontal Duct

The S.A.M.E2 system is suitable for installations where absorption distances are short, less than 1500 mm, and/or low duct temperatures are in effect. S.A.M.E2 are used in applications with restricted duct dimensions.

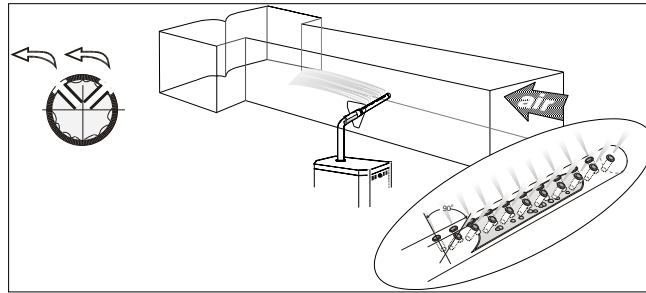

Illustration 13 - Steam Absorption Manifold (S.A.M.E2) Horizontal Duct

### Steam Absorption Manifold (S.A.M.E2) Vertical Duct

The S.A.M.E2 system for vertical ducts is used when the absorption distances are normal and the requirement is for an economical and efficient solution.

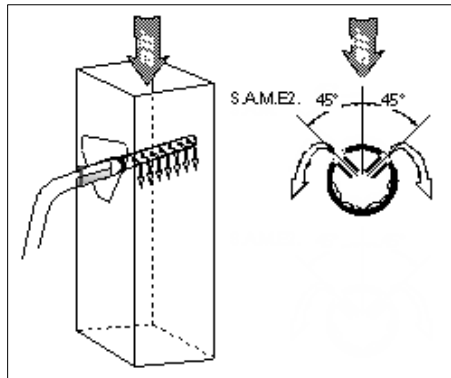

Illustration 14 - Steam Absorption Manifold (S.A.M.E2) Vertical Duct

### Multi-Steam System

The Multi-Steam system is used in critical locations in air handling systems, particularly where absorption distances are very short, less than 900 mm, or where low air duct temperatures are present. The Multi-Steam is custom made to the dimensions of the duct or AHU.

Instructions to install the Multi-Steam system are described in a specific installation instructions manual enclosed with the Multi-Steam system.

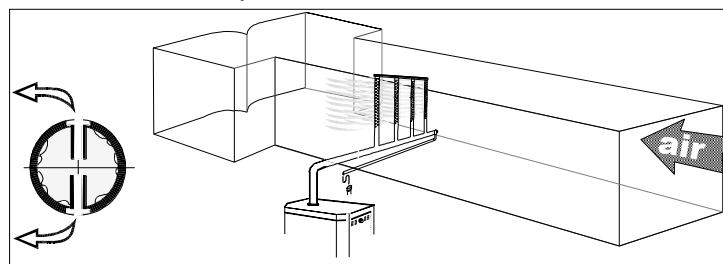

Illustration 15 - Multi Steam System



## Steam Dispersion General Recommendations

Follow these general rules based on the steam capacity of the humidifier:

- The connection pipe sizes between the SKS4 humidifier and the steam distributor in the duct must be:
  - 51mm for capacities up to 41 kg/h
  - 76mm for capacities up to 110kg/h
  - 100mm for capacities up to 200kg/h
  - 125mm for capacities up to 314kg/h
- For all humidifiers having a capacity below 100kg/h, use standard Neptronic S.A.M.E2 steam distribution pipes. A Multi-Steam system can be offered if shorter absorption distances are required.
- For all humidifiers having a capacity above 100kg/h, use the Multi-Steam system.
- For all humidifiers having a capacity above 314kg/h, use 2 Multi-Steam units per air handling unit (AHU) or air duct with an equal duty split to each Multi-Steam system.

## S.A.M.E2 System

### Positioning the S.A.M.E2

The steam manifold must be mounted and secured through the side of the air handling unit or duct. Ensure that provisions are made for safe accessibility, ideally with an observation light and window. Ensure that the construction of the duct wall is suitable enough to support the steam pipe for the duration of the installation life.

The dimension of the hole size in the duct must be as follows:

Steam Manifold Ø	Hole Size ØA
54 mm	51 mm
	76 mm

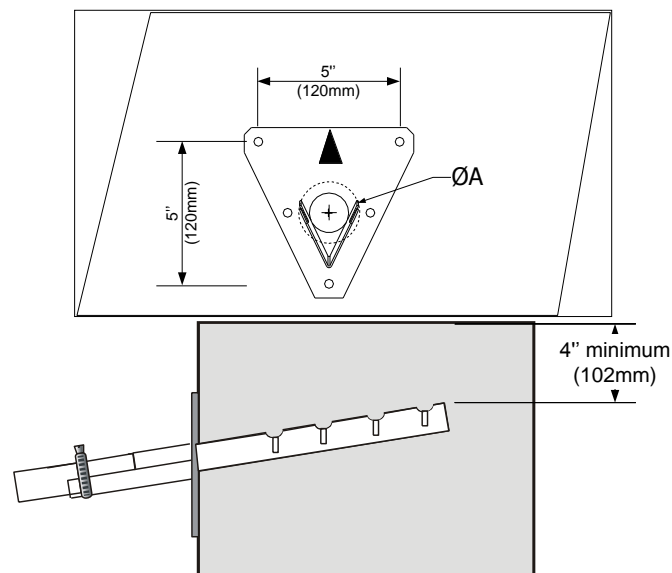

Illustration 16 - Duct Hole Dimensions and Minimum Distance



**WARNING: Risk of condensation. Ensure that the minimum distance at the end of the manifold is at least 102 mm from the top of the duct.**



### Placement of Steam Pipe in Horizontal Duct

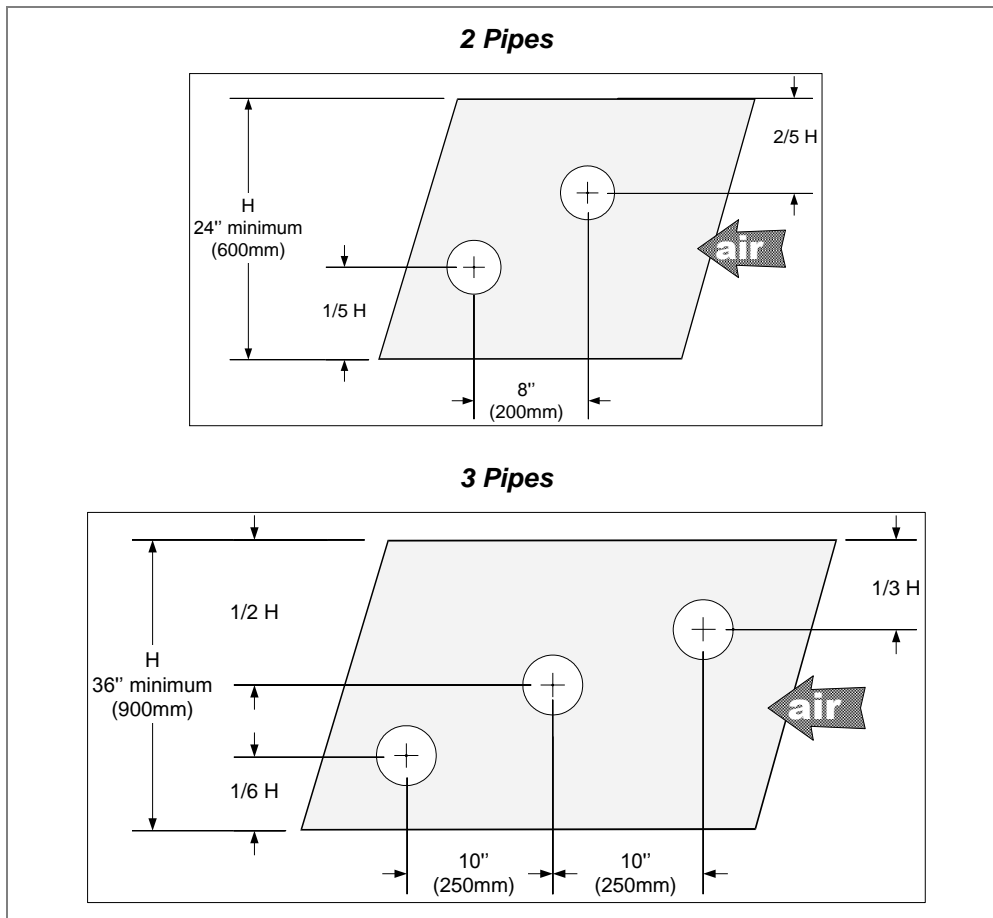

Illustration 17 - Pipe Placement: Horizontal Duct



Note: Steam pipe must be supported on the end by appropriate duct hanger or strap (supplied by others).

### Placement of Steam Pipe in Vertical Duct

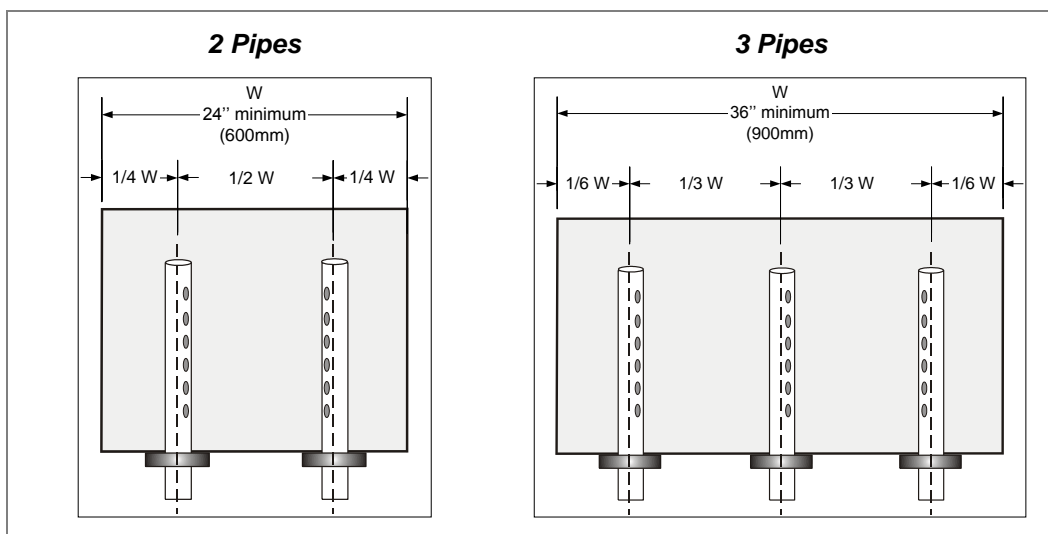

Illustration 18 - Pipe Placement: Vertical Duct

## Steam Pipe Work to Duct Connections with S.A.M.E2

### Models SKS4-050-SLP

For these models, a single  $\text{\O}51\text{mm}$  feed pipe must be connected to two S.A.M.E2 steam manifolds with a suitable reduction at the lowest point to allow a  $\text{\O}15\text{mm}$  condensate drain from the main steam supply.

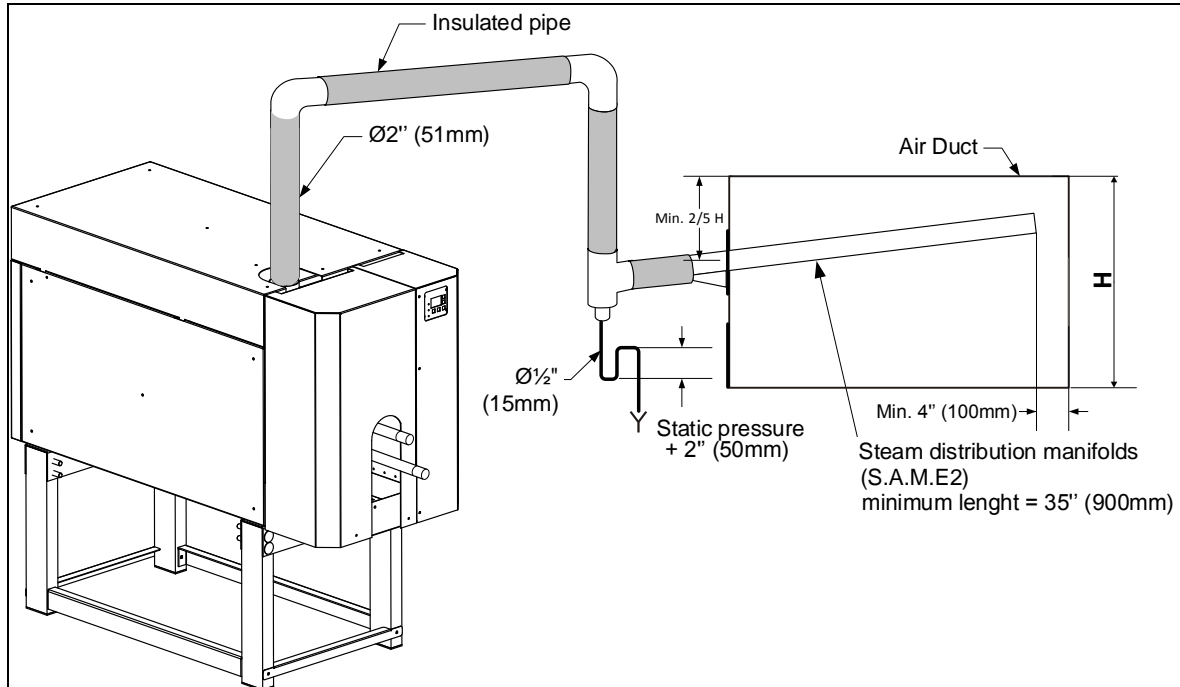

Illustration 19 - SKS4-050-SLP Steam Pipe Connections

### Models SKS4-100-SLP

For these models, a single  $\text{\O}76\text{mm}$  feed pipe must be connected to two S.A.M.E2 steam manifolds with a suitable reduction at the lowest point to allow a  $\text{\O}15\text{mm}$  condensate drain from the main steam supply.

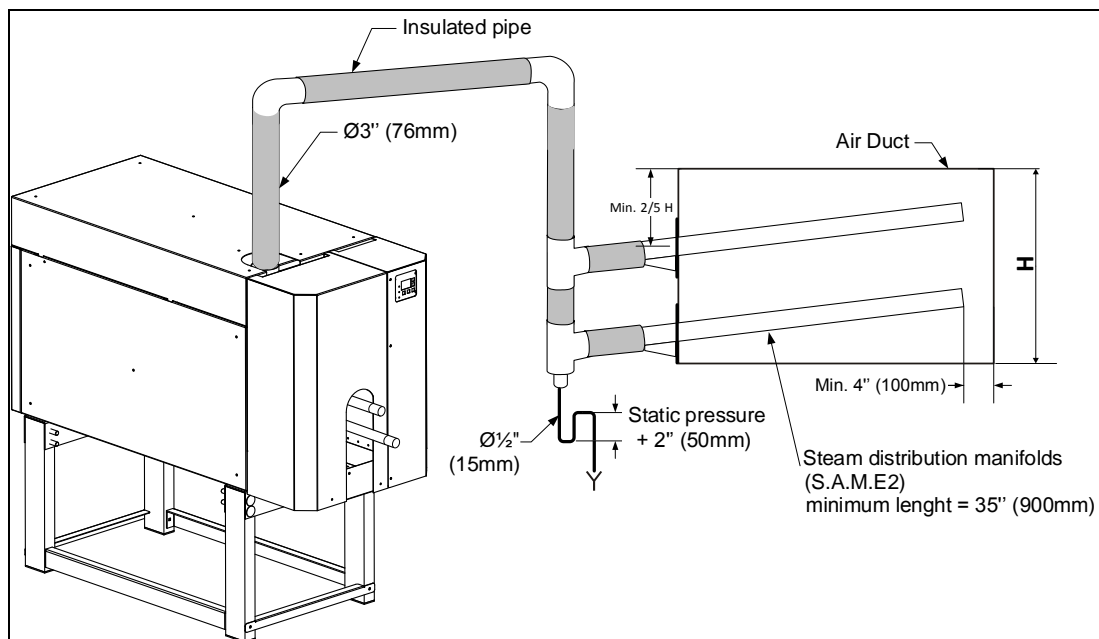

Illustration 20 - SKS4-100-SLP Steam Pipe Connections



Models SKS4-130-SLP & SKS4-190-SLP

For these models, a single  $\text{Ø}76\text{mm}$  feed pipe must be connected to three S.A.M.E2 steam manifolds with a suitable reduction at the lowest point to allow a  $\text{Ø}15\text{mm}$  condensate drain from the main steam supply.

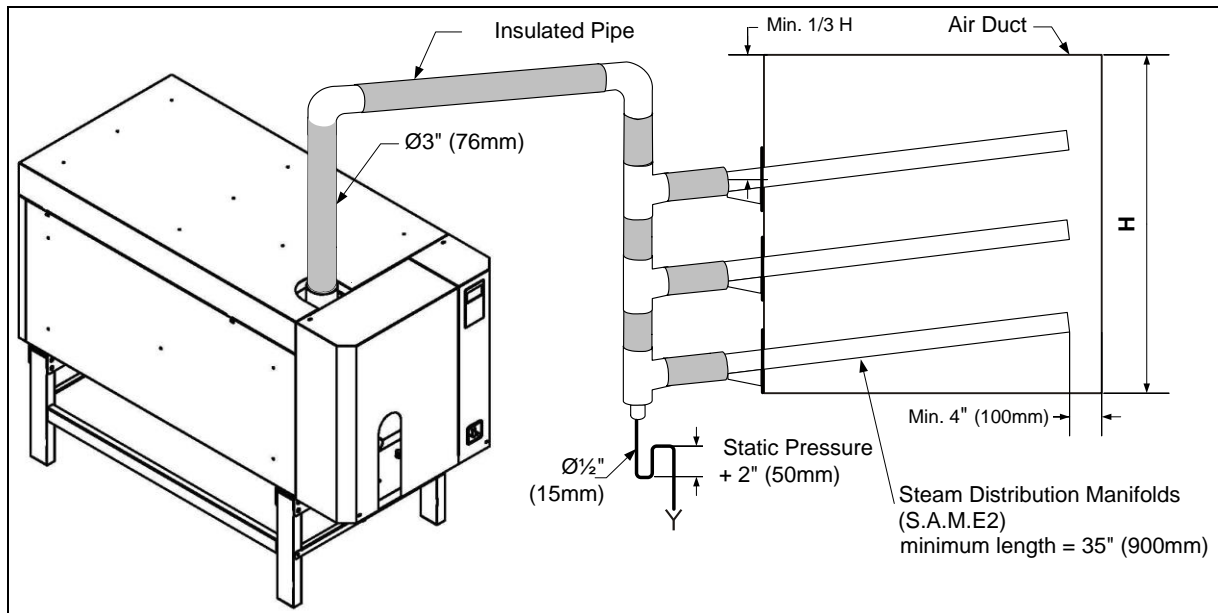

Illustration 21 - SKS4-130-SLP & SKS4-190-SLP Steam Pipe Connections



## Multi-Steam System

### Selection of Multi-Steam System

- For all Multi-Steam units, use the Neptronic Humidisoft program to size the unit.
- Where two Multi-Steam units are required (duties in excess of 314kg/h), make your selection using the following rules:
  - Divide the air flow volume in half.
  - Divide the AHU / air duct **width** in half.
  - **Height** of the duct must remain at 100% its height.
  - This will size the Multi-Steam units so that they can be placed side by side.
- For installation of Multi-Steam units, refer to the Neptronic Multi-Steam Installation Instructions.

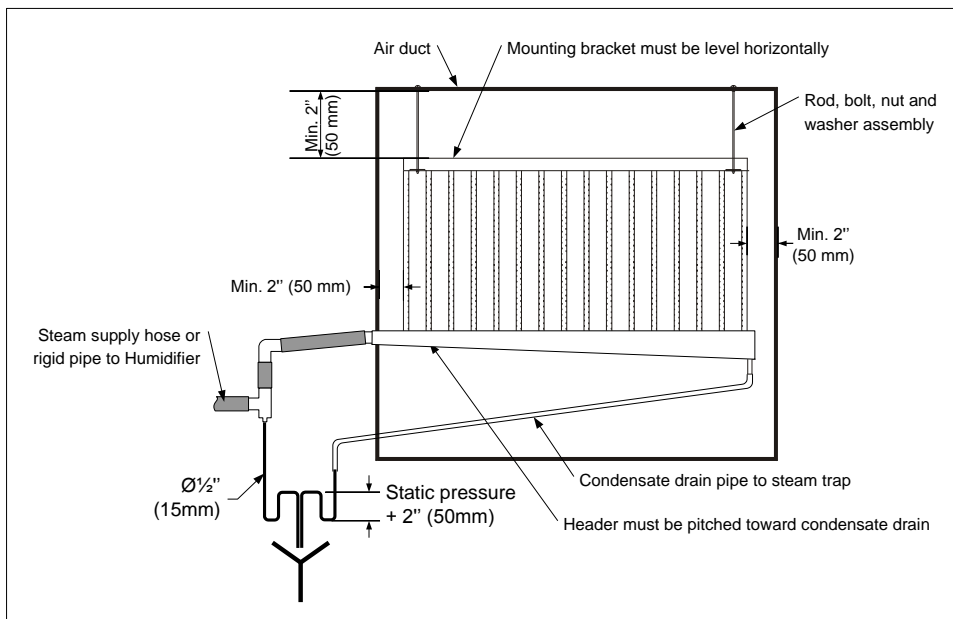

Illustration 22 - Multi-Steam (Horizontal Duct)

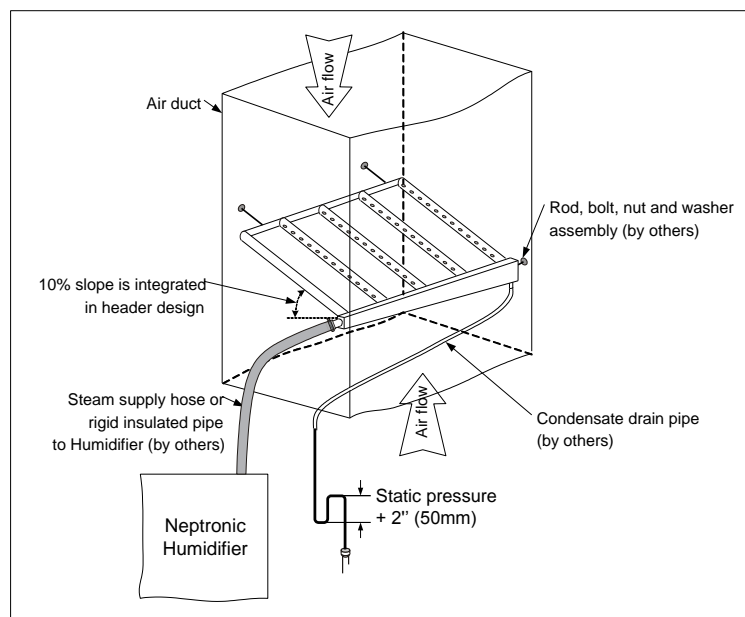

Illustration 23 - Multi-Steam (Vertical Duct)





### Steam Pipe Work to Duct Connections with Multi-Steam

#### Models SKS4-050-SLP to SKS4-690-SLP

For these models, a single Ø51mm, Ø76mm, Ø100mm or Ø125mm feed pipe must be connected to a single Multi-Steam with a suitable reduction at the lowest point to allow a Ø15mm condensate drain from the main steam supply.

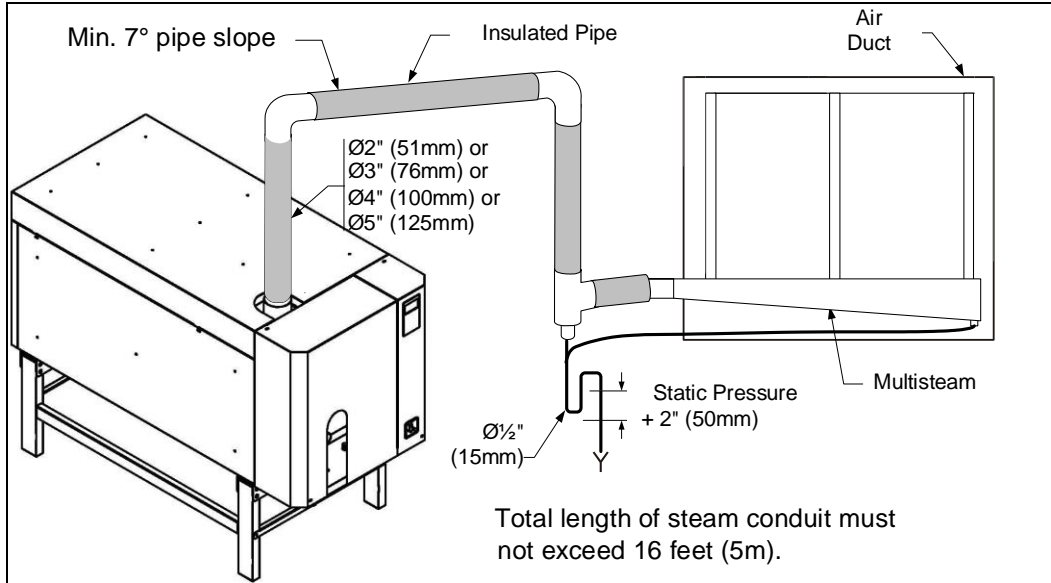

Illustration 24 - SKS4-050-SLP to SKS4-690-SLP Steam Pipe Connections

#### Models SKS4-950 & 1250-SLP, SKS4-333 & 667-CHP

For these models, two Ø100mm or Ø125mm steam outlets must be connected to two Multi-Steam with a suitable reduction at the lowest point to allow a Ø15mm condensate drain from the main steam supply.

If the two Ø15mm condensate pipes are connected, the common condensate drain must be Ø20mm.

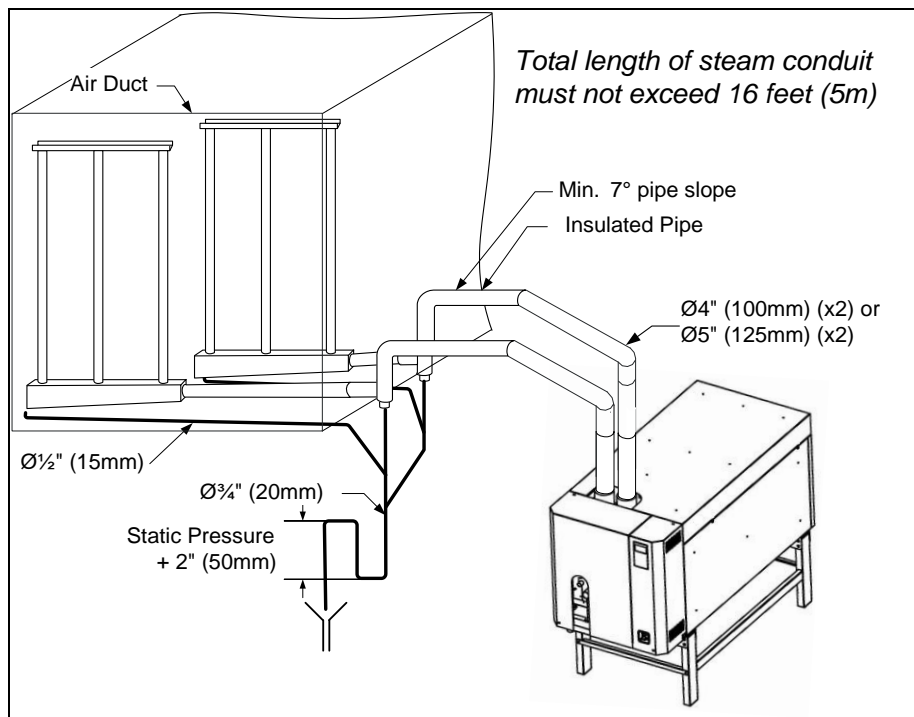

Illustration 25 - SKS4-950 & 1250-SLP, SKS4-333 & 667-CHP Steam Pipe Connections

## Step 3 - HTHW / Raw Steam Supply Connection



**HTHW / Raw steam supply piping must conform to local codes and regulations. Any installation work must be carried out by suitably qualified personnel.**

- Risk of distortion and failure. Steam piping installation must be supported so that no strain are imposed on the humidifier steam inlet flange and control valve.
- Pipes must be inspected for dirt and chips after threading and reaming the end of pipes.

## Union Dimensions and Installation

Table 8 - HTHW / Raw Steam Supply Dimensions

<i>Model</i>	<i>HTHW / Raw Steam Inlet</i>	<i>Condensate Return Outlet</i>
<b>SKS4-050/100/130-SLP</b>	Ø20mm	Ø20mm
<b>SKS4-190/290-SLP</b>	Ø25mm	Ø20mm
<b>SKS4-390/500/690-SLP</b> <b>SKS4-333-CHP</b>	Ø32mm	Ø32mm
<b>SKS4-950-SLP</b>	Ø40mm	Ø40mm
<b>SKS4-1250-SLP</b> <b>SKS4-667-CHP</b>	Ø32mm (x2)	Ø32mm (x2)



*Note: Models **SKS4-1250-SLP** and **SKS4-667-CHP** are equipped with two heat exchangers and therefore have two raw steam inlets and two condensate return outlets.*

## Typical Raw Steam Installation

- A strainer as well as a shut off valve (not supplied) must be installed upstream to the actuated control valve on the raw steam supply pipe.
- Vacuum breakers (not supplied) must be installed between the SKS4 heat exchanger and the actuated control valve.
- Brass coupling must be used between the heat exchanger stainless steel pipes and steam inlet / condensate outlet piping.
- The condensate must be evacuated efficiently. Therefore, a condensate pocket (not supplied) and steam trap must be installed to ensure proper condensate elimination.
- After installation, field piping and humidifier steam piping must be checked for leaks. All leaks **MUST** be sealed prior to commissioning the Humidifier.

## Steam Supply Size

The size of the steam supply pipe and the control valve must be calculated considering **1.5 times more raw steam compared to the clean steam** produced and distributed into the AHU.

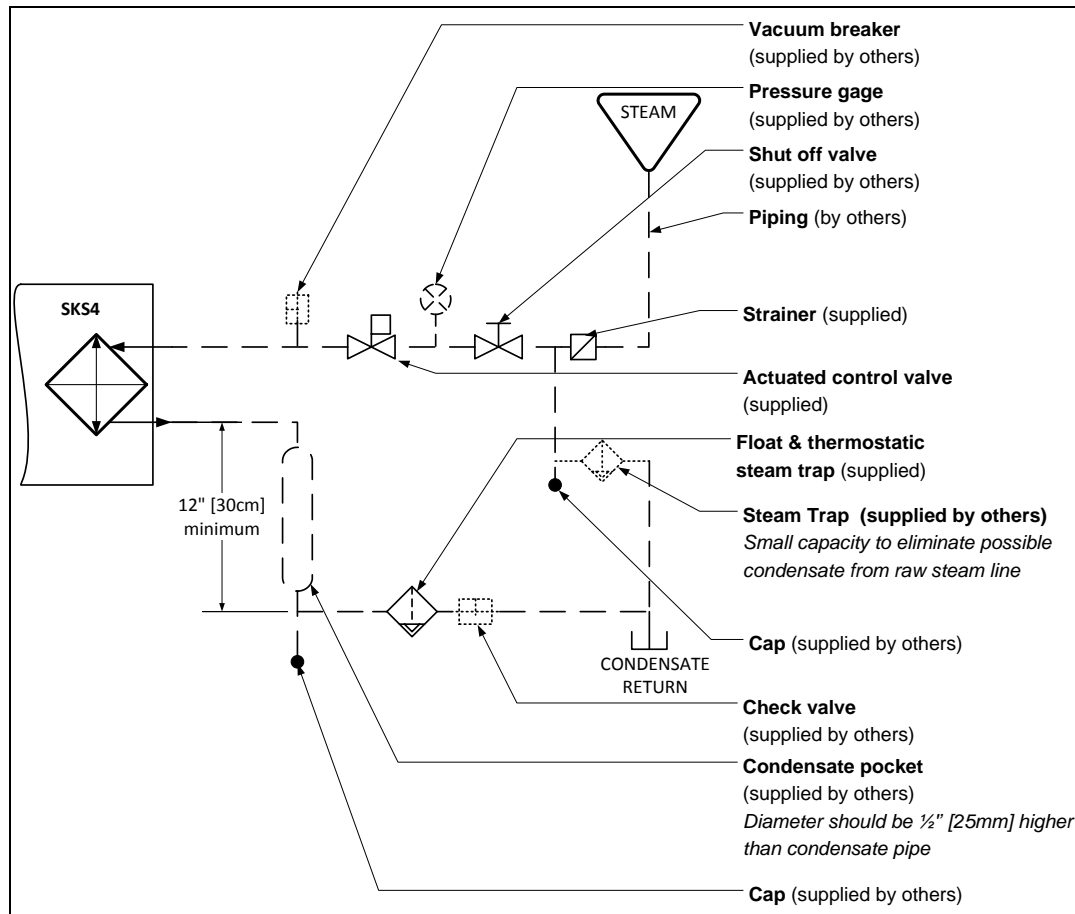

Illustration 26 - SKS4 Pipework for Raw Steam

## Raw Steam Supply and Condensate Installation

- Connect the raw steam inlet to an adequate steam supply with actuated control valve, strainer and shut off valve.
- One control valve is required for each raw steam inlet.
- Control valve must be fitted with a mechanism and be electrically wired so that the valve returns to the closed position when no air flow is detected in the AHU.
- In case of two condensate outlets, each individual condensate outlet requires an individual steam trap. Do not "group trap".
- Float and thermostatic type steam traps are recommended for the condensate from the heat exchanger and must be fitted no less than 30cm below the condensate outlets, with condensate pocket fitted before the trap.
- Thermostatic type steam traps are recommended as the small capacity trap to eliminate condensate from the raw steam line.



## Typical HTHW Installation

### HTHW Supply Size

The size of the HTHW supply pipe and control valve must be calculated considering **0.8kW of HTHW for each kg of clean steam** produced and distributed into the AHU.

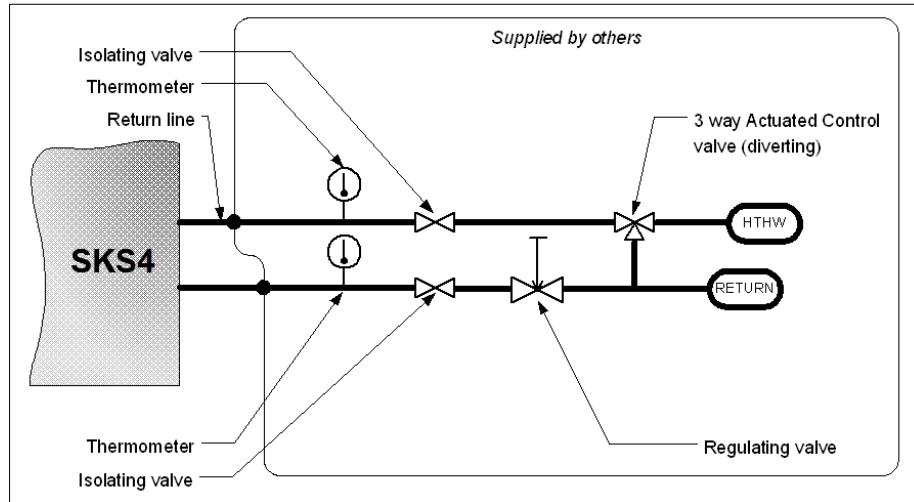

Illustration 27 - SKS4 Pipework for HTHW

### HTHW Supply and Condensate Installation

- Connect the HTHW inlet(s) to an adequate HTHW supply with 3 way diverting control valve, isolating valves, regulating valve and thermometers.
- Only one (1) control valve is required irrespective of the number of HTHW inlets.
- Control valve must be fitted with a mechanism and be electrically wired so that the valve returns to the closed position when no air flow is detected in the AHU.
- Return outlet(s) must be connected to the HTHW with an isolating valve.
- Thermometers must be installed on the HTHW supply line and the return line close to the humidifier.

### Positioning the Control Valve

- Install the actuated valve (AM060 actuator with globe valve) between 20 to 30 degrees from vertical in order to reduce the convection heat to the actuator.

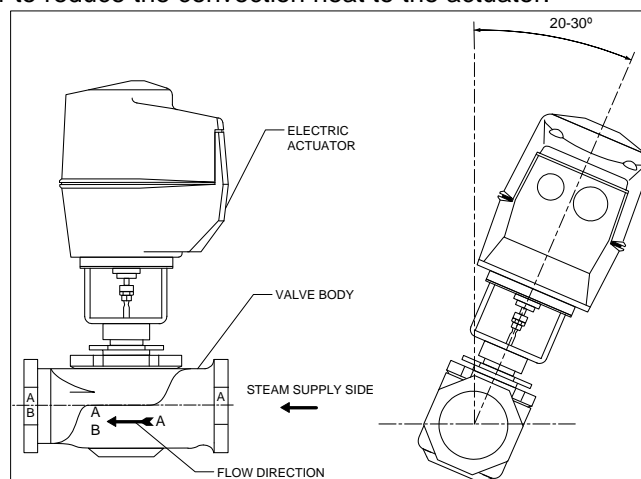

Illustration 28 - Control Valve Orientation and Angle



## Step 4 - Water Supply Installation



**Water supply installation must conform to Local and National Codes.**  
**Any installation work must be carried out by suitably qualified personnel.**

### Water Inlet Specifications

The SKS4 humidifier is designed to be used with tap, reverse osmosis and deionised water.

- For normal operation, pre-treatment of water is not necessary.
- As the humidifier is equipped with the Neptronic Anti-Foaming Energy Conservation (AFEC) system, which drains the humidifier in the presence of foam to ensure clean and safe operation, the use of softened water is not required.

If a third party requires a water softener for any operational or equivalency purposes, ensure that the water dilution feature is enabled. To enable this function, configure the value of the *BlowdownRate* setting located in the *Installation* menu (see page 46 for details).

- Water Inlet Specifications:
  - Maximum water supply pressure: 170 to 480kPa
  - Minimum water temperature: 4°C
  - Maximum water temperature: 30°C

### Water Supply Line Installation

- To facilitate servicing, a shut off valve (not supplied) must be installed in the water line, close to the humidifier.
- It is recommended to install a water hammer arrestor, in order to absorb hydraulic shock and minimize water hammer when the fill valve closes.
- To install the water supply, connect to the male threaded part of the pipe and tighten it.

<i>Model</i>	<i>Water Inlet Connection Size</i>
<b>SKS4-XXXX</b>	15mm NPT Male

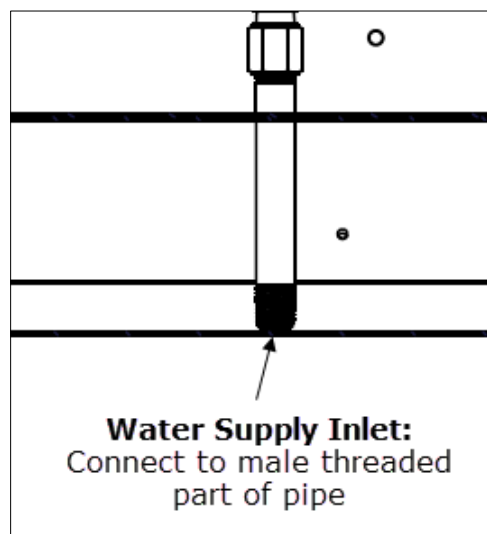

Illustration 29 - Water Supply Connections



## Step 5 - Water Drain Connection



Water drain installation must conform to Local and National Codes.  
Any installation work must be carried out by suitably qualified personnel.

### Water Drain Specifications

- Water drain temperature: 60°C

Model	Water Drain Outlet Connection Size	Pipe Ø for Length More Than 4.5m	Maximum Drain Flow Rate
SKS4-050 to 290-SLP	Ø22mm	Ø40mm	48 l/min
SKS4-390 to 1250-SLP, SKS4-333 & 667-CHP	Ø35mm	Ø50mm	96 l/min

### Water Drain Installation

- Water drain outlet connection must be connected to drain pipe of sufficient size.
- It is recommended to use Ø22mm or Ø35mm minimum standard copper or stainless steel hydraulic pipes.
- The installed drain piping must be rated for a temperature of 100°C.
- Water main drain and drip pan must be kept separate to the open drain. Do not connect the main drain and the drip pan before the open drain, they must not be piped together or to other appliances.
- Minimum water drain pipe gradient must be of 6.5mm per 300mm horizontal run.
- No drain trap must be installed on the humidifier drain pipes.
- The maximum equivalent pipe length of the main drain must not exceed 4.5m between the drain outlet of the humidifier and the open drain. Otherwise, the drain pipe diameter must be increased to the value indicated in the table above.
- A minimum 25mm air gap must be kept between the connection of the humidifier drain pipes and the open drain line.

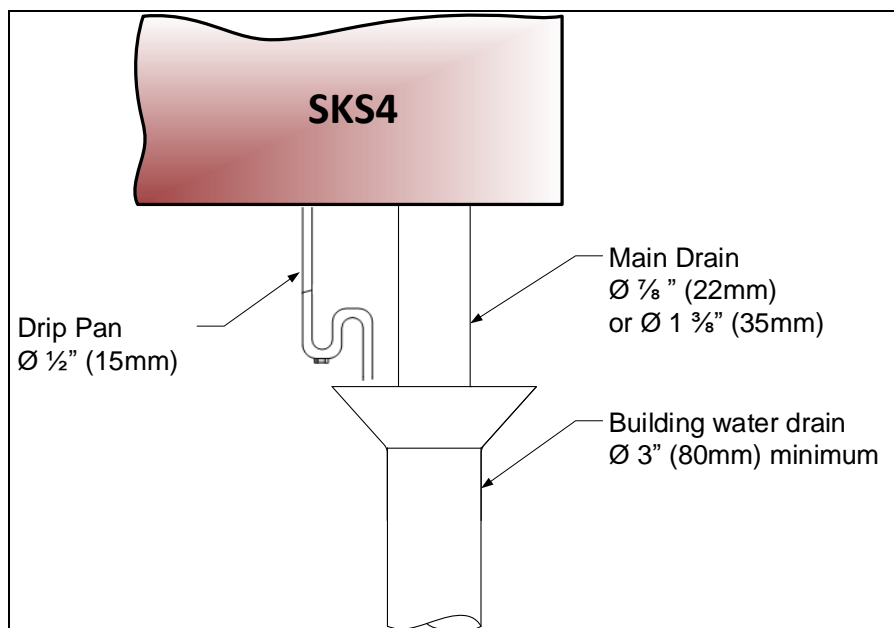

Illustration 30 - Water Drain Connections



## Stage 6 - Electrical Supply Connections



**CAUTION:** Risk of electric shock. Disconnect the humidifier from the electric supply before proceeding with the connection.



All work concerned with electrical installation **MUST** only be performed by a qualified electrician and must conform to the procedure, regulation and local codes.

- Use copper conductors only.
- The electrical supply must also be isolated for the purpose of emergency and servicing.
- The isolator must have a contact separation of at least 3mm.
- The humidifier is equipped with a built-in disconnect switch, to turn off the power without opening any access doors.
- An external over current protection must be installed on the supply, adjacent to the humidifier. It is also recommended to install a circuit breaker.
- To provide strain relief to the supply cable, install a knock-out (not supplied) at the bottom of the electrical compartment of the humidifier.
- Ensure that the size of the wire conductors is appropriate for the current supplied.
- Ensure that the incoming power cable is secured via a suitably sized cable gland.
- Ensure that each terminal connection is properly secured.
- Ensure that the ground conductor is equipped with a ring terminal and is connected directly to the electrical panel. Do not use raw steam or HTHW piping as an electrical ground.

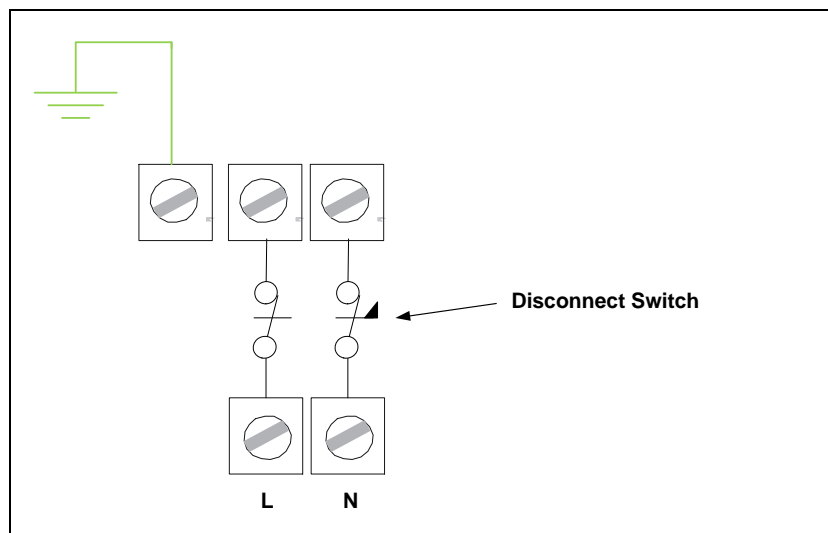

Illustration 31 - Power Supply Connection

## Electrical Power Supply

The SKS4 humidifier requires the following single phase power supply:

Model	Voltage	Current
SKS4-050 to 290-SLP	240Vac - 1ph	4A
SKS4-390 to 1250-SLP, SKS4-333 & 667-CHP		8A

# Step 7 - Electrical Control Connections

## Printed Circuit Board

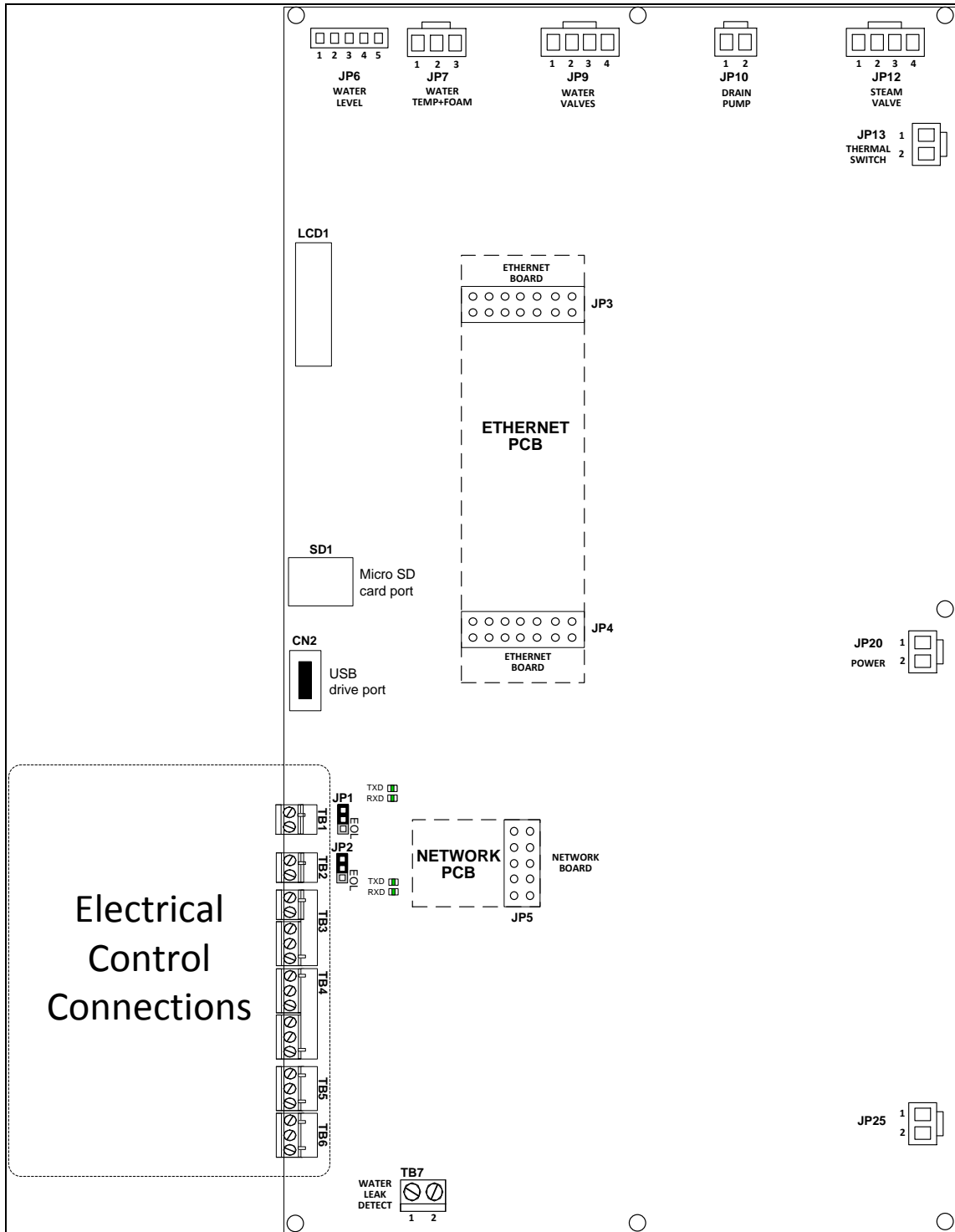

Illustration 32 - Printed Circuit Board Interface

The Printed Circuit Board (PCB) is equipped with an advanced microprocessor, which controls all of the functions of the humidifier. All electrical control connections have been grouped alongside the bottom left corner of the PCB.



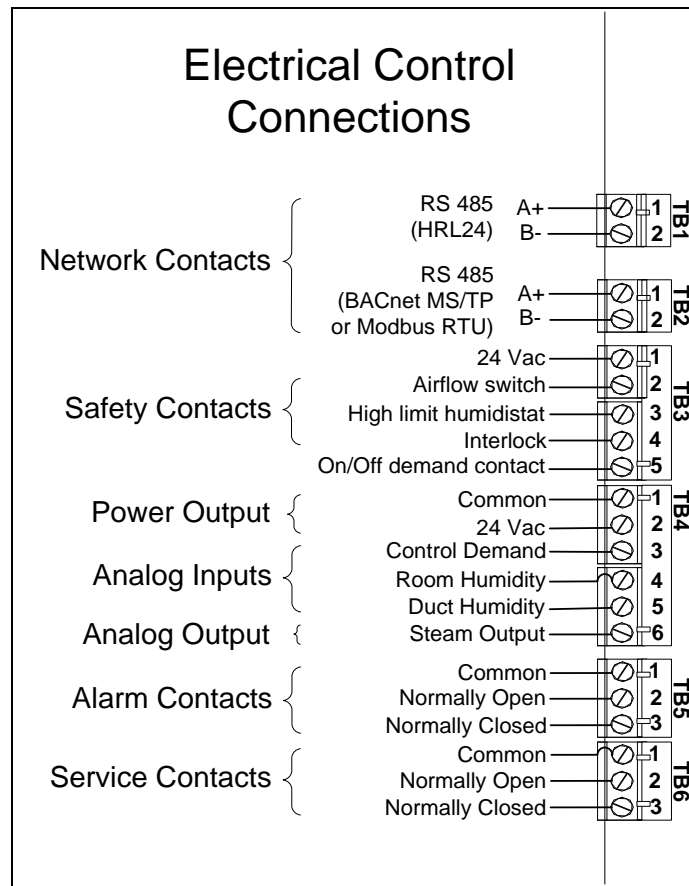

Illustration 33 - Electrical Control Connections

## Safety Contact Connections

The **Airflow switch** contact must be wired between terminals TB3 1&2. If this contact opens, operation of the SKS4 unit will stop. The unit will display the airflow switch as open, but will not generate an alarm. If an airflow switch is not used, install a jumper between terminals TB3 1&2.

The **High limit humidistat** contact must be wired between terminals TB3 1&3. If this contact opens, operation of the SKS4 unit will stop and an **alarm** message will be displayed. If a high limit humidistat is not used, install a jumper between terminals TB3 1&3.

The **Interlock** must be wired between terminals TB3 1&4. If this contact opens, operation of the SKS4 unit will stop. The unit will display the Interlock as open, but will not generate an alarm. If Interlock is not used, install a jumper between terminals TB3 1&4.

## Dry Contacts

Two series of volt free contacts are provided:

1. Alarm Contacts
  2. Service Contacts
- These contacts are used to switch a low voltage, ideally 24V, with a switching current of no more than 3 Amps.
  - Each series has one Normally Closed contact and one Normally Open contact.
  - It is recommended to use the Normally Closed contact, as this contact will open in the event of a humidifier fault.

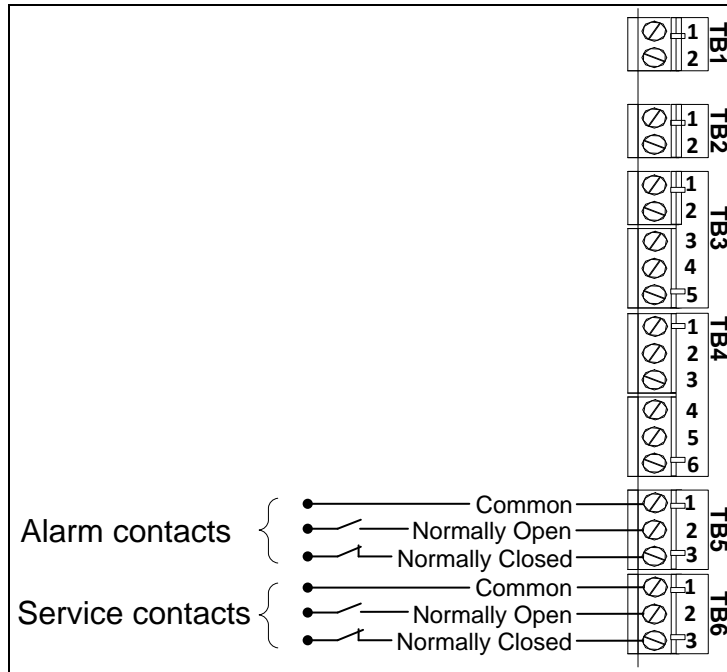

Illustration 34 - Alarm and Service Contact Wiring

## Humidifier Control

### Analog Signals

For operation of modulating humidifiers, the analog signal(s) must be connected between terminals TB4 1 and TB4 3, 4 and/or 5. To configure the source of the signal(s), access the *Control* sub-menu located in the *Installation* menu (see page 46).

### Humidity Control by Humidistat (External Mode)

Humidity controlled externally, using HRO20 humidistat:

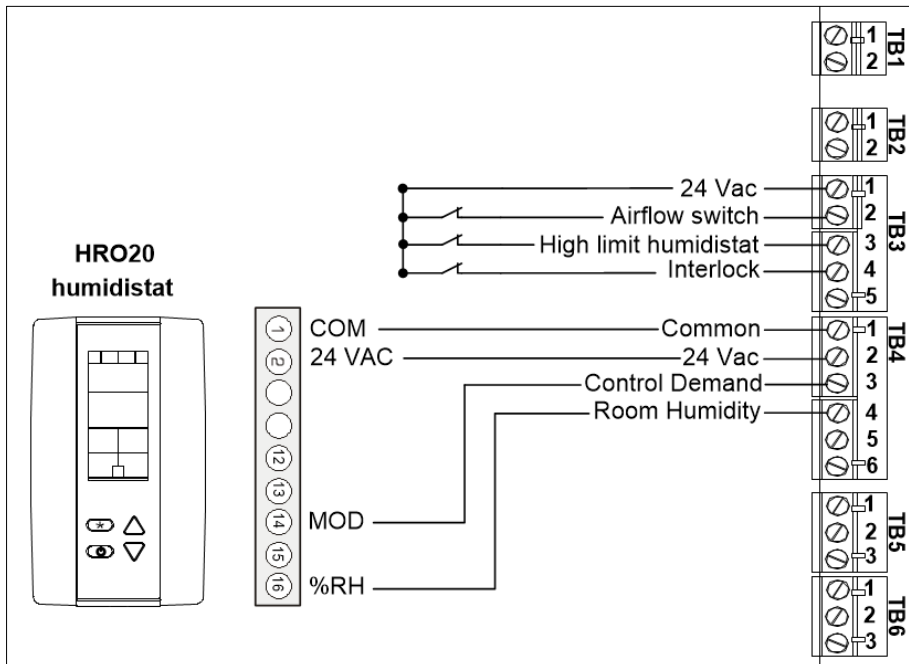

Illustration 35 - Control Signal from HRO20 Humidistat



Humidity controlled externally, using HRO20 humidistat with SHR10 or SHC80 as space sensor:

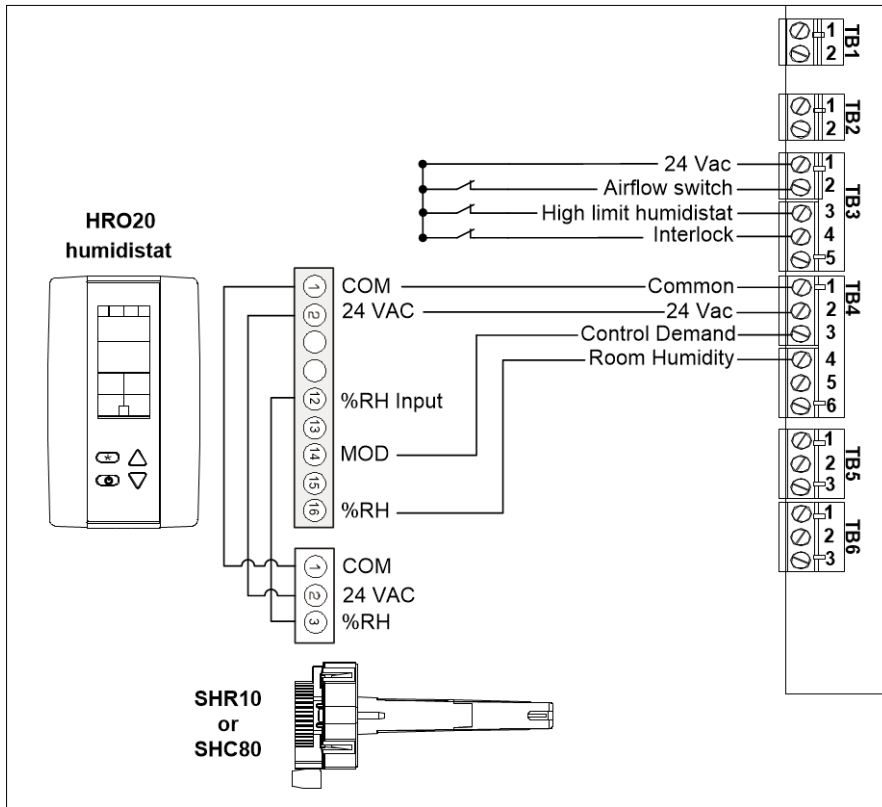

Illustration 36 - Control Signal from HRO20 Humidistat with Remote Humidity Sensor (SHR10 or SHC80)

### Humidity Control by Humidifier (Internal Mode)

Humidity controlled internally, using SHR10 or SHC80 as space sensor:

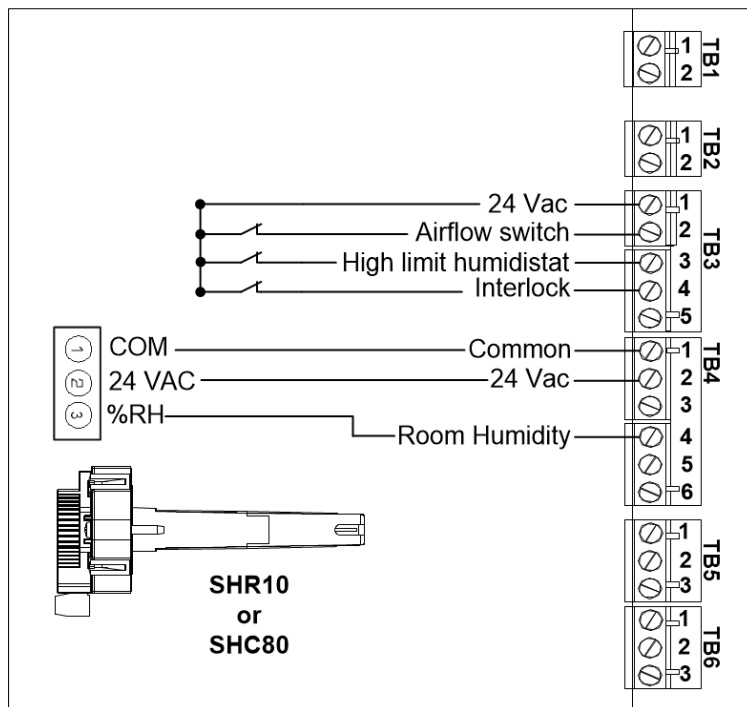

Illustration 37 - Humidity Signal from Remote Humidity Sensor (SHR10 or SHC80)



## Humidity Control by External Signal

Humidity controlled externally, using an external signal source:

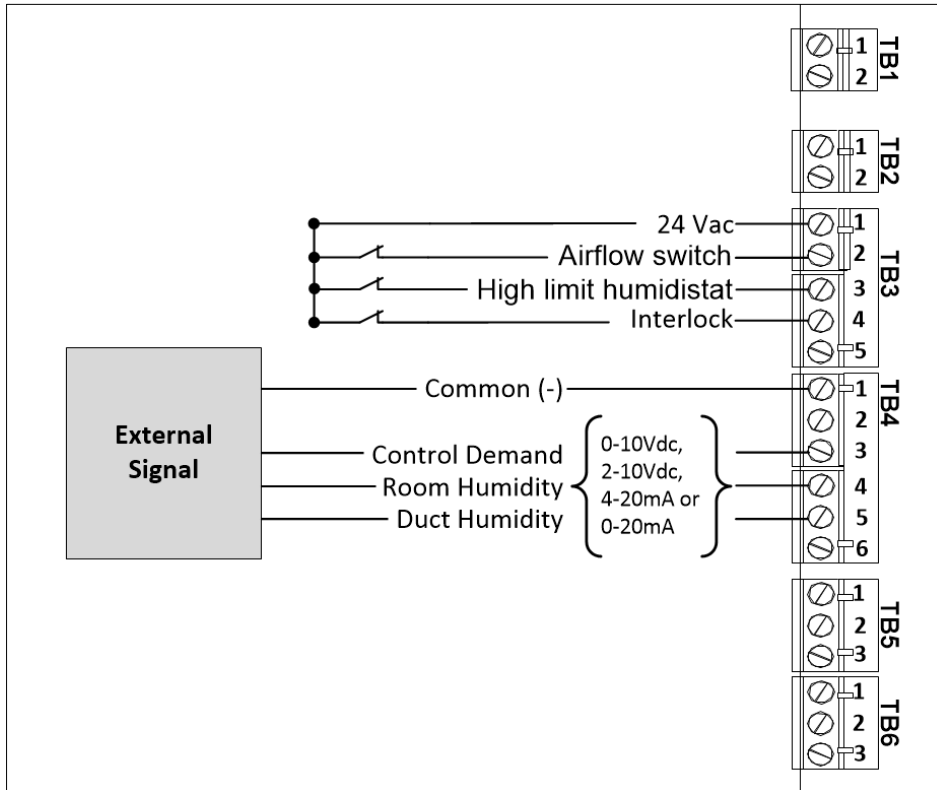

Illustration 38 - Control Signal from External Device

## Network Communication

If the control signal is from a BACnet MS/TP or Modbus RTU network, connect terminals TB2 1&2 to the network (RS485 A+ & B-).

If the control signal is from a HRL24, connect terminals TB1 1&2 to the network (RS485 A+ & B-).

The network control signal(s) must be selected by accessing the *Control* sub-menu located in the *Installation* menu (see page 46). To setup the communication parameters, access the *Integration* menu (see page 50).



*Note: BACnet MS/TP is configured by default. To change the communication interface to Modbus RTU, access the NtwrkOption setting located in the Network sub-menu of the Integration menu (see page 50).*

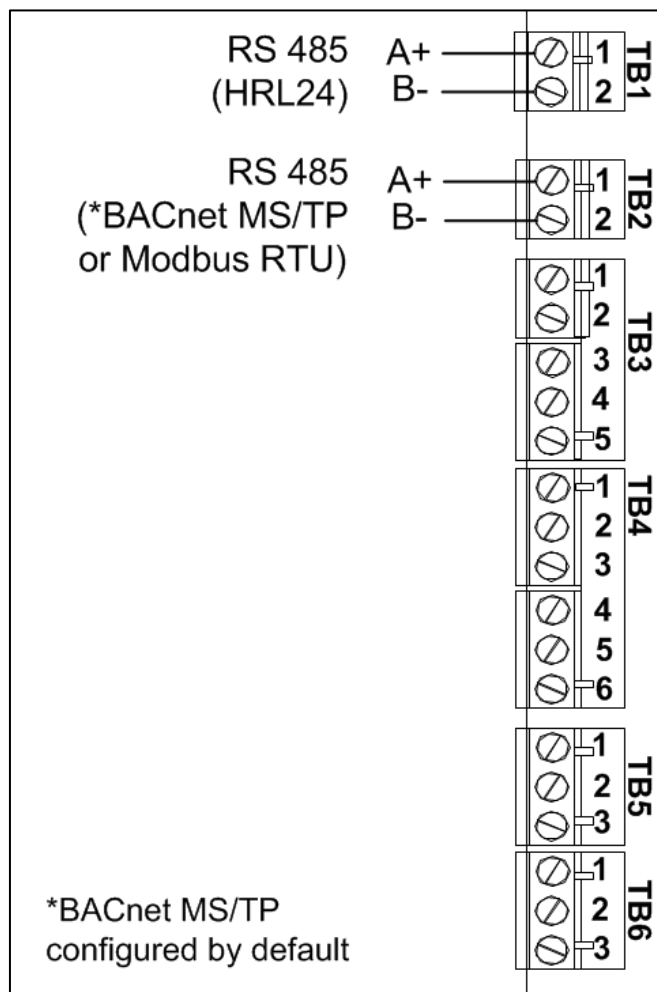

Illustration 39 - Network Communication Connections



## Controls Placement (Steam Dispersed into a Duct or AHU)

A typical humidifier control system includes the following along with the humidifier:

- A wall or return duct humidistat
- A high limit duct humidistat
- An airflow switch

Placement of these devices is critical to the proper operation of the overall system.

- The return air humidistat must always be located in the return air duct, in order to ensure accurate sensing of the air from the humidified space.
- Alternatively, a room humidistat can be used. The room humidistat must be located on an inside wall or column. It must not be near any discharge air from supply ducts or sources of heat or cold.
- The airflow switch must be placed in a position capable of accurately opening on a loss of air flow, in order to prevent the humidifier from running when there is no air to absorb humidity.
- The high limit humidistat must be positioned far enough, minimum 4.6 m, downstream of the steam dispersion manifold(s) to prevent over humidification of the duct that could result in condensation.
- Any device that may be triggered by high humidity levels in a close proximity to the steam dispersion manifold must also be positioned at least 4.6 m, downstream of the dispersion manifold(s).

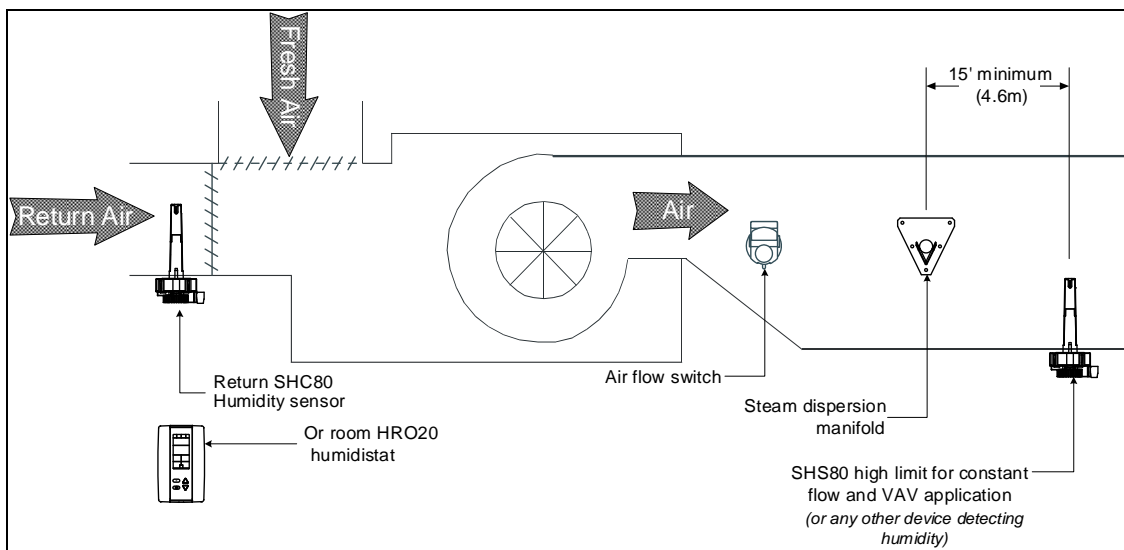

Illustration 40 - Controls Placement (Steam Dispersed into a Duct or AHU)

## Steam Actuated Valve

- For models SKS4-050-SLP to SKS4-950-SLP, SKS4-333-CHP (1 control valve), connect the humidifier to the actuated valve (AM060 actuator with globe valve) as per the illustration on the left.
- For models SKS4-1250-SLP and SKS4-667-CHP (2 control valves), connect the humidifier to the actuated valves (AM060 actuators with globe valves) as per the illustration on the right.

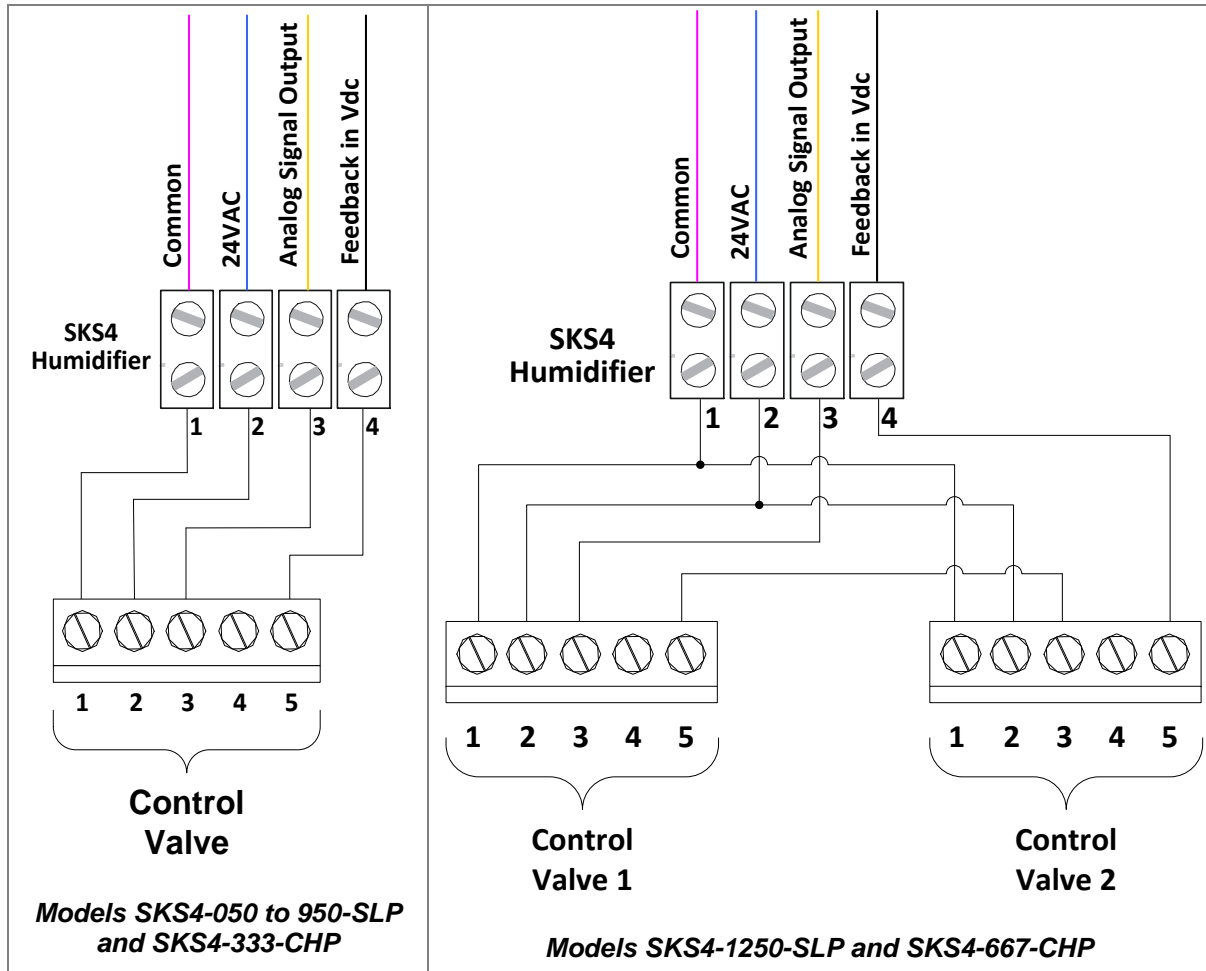

Illustration 41 - Control Valve Connection

- Ensure that DIP switch #4 is set to the “ON” position on the AM060 actuator.

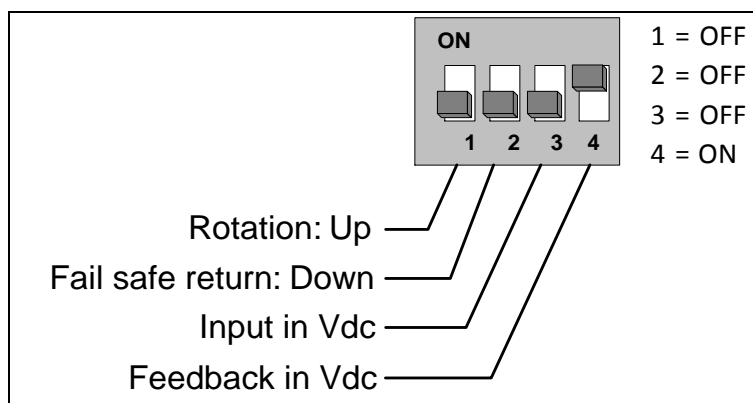

Illustration 42 - AM060 Actuator DIP Switch Settings

# Controller Configuration

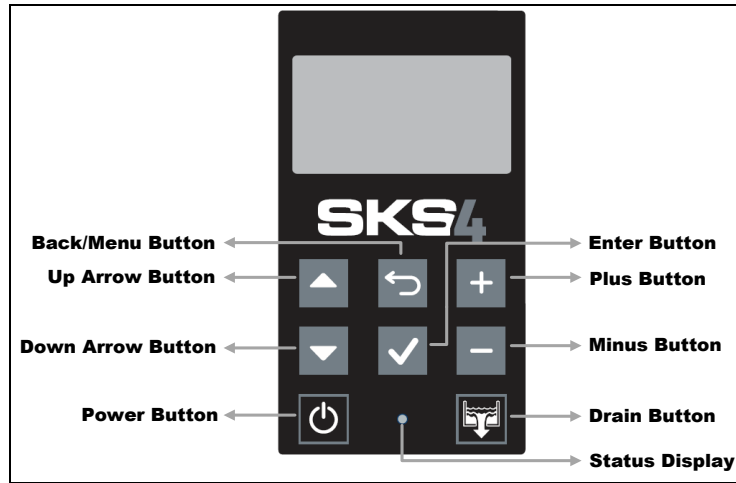













Illustration 43 - SKS4 Controller

## Control Panel Features

The following are the features of the Control Panel and their description:

Table 9 - Humidifier Control Panel Description

Feature		Description
Status Display	 (Blue)	Indicates that the humidifier is turned on. The LED will begin blinking as the system is initializing.
	 (Red)	Indicates that the alarm is issuing a warning and that the system must be verified.
	 (Off)	Indicates that the humidifier is turned off.
Power Button		The power button is used to turn the humidifier on or off. Must be pressed and held for 3 seconds to perform the related action, in order to prevent accidental activation. Even when the humidifier is powered off, the controller remains operational.
Drain Button		The drain button is used to manually activate the drain cycle. Must be pressed and held for 3 seconds to perform the related action, in order to prevent accidental activation. Even when the humidifier is powered off, a drain cycle may be initiated. <i>Once the manual drain cycle is completed, the system will automatically be powered off. To turn the humidifier back on, press and hold the power button.</i>
Up and Down Arrow Buttons	 	The up arrow button is used to scroll to the next menu item or parameter. The down arrow button is used to scroll to the previous menu item or parameter.
Plus and Minus Buttons	 	The plus button is used to increase the value of the displayed parameter. The minus button is used to decrease the value of the displayed parameter.
Back/Menu Button		The back/menu button is used to go to previous menu or to access the Main Menu page from the Idle Screen.
Enter Button		The enter button is used to advance to the next sub-menu, to access the selected option or to confirm set parameter value.





## Idle Screen

When the controller is in operation, the unit displays the following information on the Idle Screen:

Table 10 - Idle Screen Display Description

Setting	Default	Range (* indicates no configuration; display only)	Description/Notes
HumDemand:	Current value	* (min: 0.00%, max: 100.00%)	Displays the current humidity demand value.
ControlState:	Current value	* (Off, Normal, LowLimit, HighLimit, NoAirFlow, Interlock)	Displays the current state of the safety control circuit and whether the circuit has been disconnected due to a safety switch.
PowerOutput:	Current value	* (min: 0.00%, max: 100.00%)	Displays the measured power output of the system as a percentage of the total power.
State:	Current value	* (Off, Idle, LineRinse, TankRinse, Filling, Draining, Heating, Boiling, Alarm)	Displays the current state of operation of the humidifier.

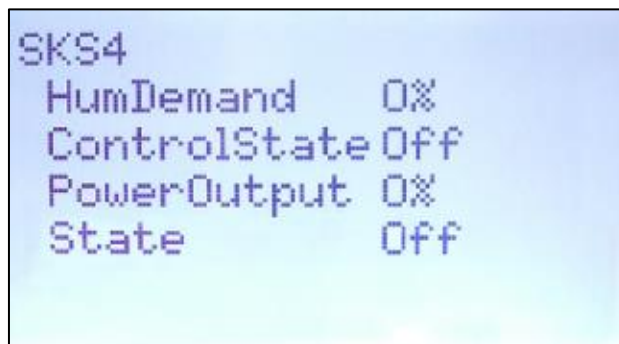

Illustration 44 - Idle Screen Display

## Menu Access

- From the Idle Screen, the Main Menu can be accessed by pressing the Back/Menu button ↵, enabling access to the General menu.
- To view other menu options and perform configurations to the system, press Enter ✓ while on the Idle Screen to advance to the Login Screen, where a valid password must be entered.
- Four different passwords can be used, each granting access to an additional menu option depending on the access level assigned to the provided password.
- If a password of higher access is provided, all menu options accessible with the use of a lower level password will also be unlocked.

Table 11 - Access Levels

Access Level	Password	Menu Unlocked	Description/Notes
1	None	General	Grants access to General menu.
2	2222	User	Grants access to General and User menus.
3	3322	Service	Grants access to General, User and Service menus.
4	4433	Installation	Grants access to General, User, Service and Installation menus.
5	5544	Integration	Grants access to General, User, Service, Installation and Integration menus.

Note: To modify or retrieve lost passwords, please contact factory.



- A. After accessing the Login Screen, use the + or - buttons to increase or decrease the value of the number that is highlighted.
- B. Use the ▲, ▼ buttons to scroll to the next or previous number.
- C. Press Enter ✓ to confirm the password once completed. If you enter the wrong password, the SKS4 controller displays a "Login Failed" message.
- D. The Back/Menu button ↵ may also be used to return to the Idle Screen display.



Illustration 45 - Login Screen

## Menu Navigation and Configuration

- A. Use the ▲, ▼ buttons to select the desired menu category and press Enter ✓ to advance to the next sub-menu.
- B. Use the + and - buttons to increase and decrease values. Use the ▲, ▼ buttons to scroll to the next or previous parameter. Values are saved as soon as a change is made.
- C. Press the Back/Menu button ↵ to go back one menu. The current menu location is displayed at the top of the screen.
- D. To exit completely, press the Back/Menu button ↵ until you return to the Idle Screen. After 5 minutes of inactivity, the controller will automatically return to the Idle Screen.

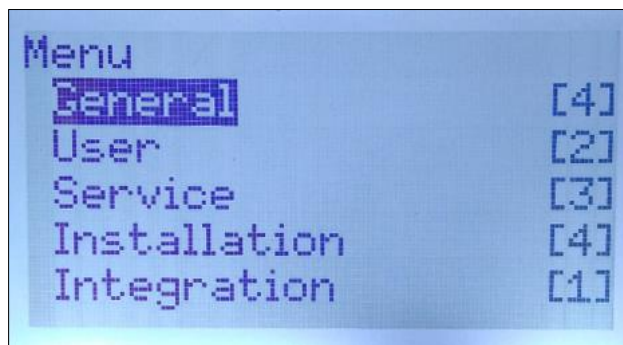

Illustration 46 - Main Menu Page

*Note: Available settings and range selections may vary depending on current configuration. The tables in the following sections display all the possible selections. The Description/Notes column indicates the conditions required for the associated setting to appear.*

## Menu - General [Level 1 - No password required]

Press the back/menu button from the Idle Screen to access the General menu.

Sub-Menu	Setting	Default	Range (* indicates no configuration; display only)	Description/Notes
Status	AirFlow:	Closed	* (Closed, Open)	Displays the status of the airflow switch. If <i>Open</i> is displayed, it indicates that the airflow is not detected by the air pressure switch.
	SupplyHighLimit:	Closed	* (Closed, Open)	Displays the status of the high limit contact. If <i>Open</i> is displayed, it indicates that the humidity level has exceeded the setpoint on the high limit humidistat.
	Interlock:	Closed	* (Closed, Open)	Displays the status of the interlock. If <i>Open</i> is displayed, it indicates that the humidifier is stopped as a result of the interlock safety being open.
	OccupancyState:	<i>Current value</i>	* (Occupied, Unoccupied, Vacant, Off)	Displays the current occupancy state.
	ControlState:	<i>Current value</i>	* (Off, Normal, LowLimit, HighLimit, NoAirFlow, Interlock)	Displays the current state of the safety control circuit and whether the circuit has been disconnected due to a safety switch.
	BoilerDemand:	<i>Current value</i>	* (min: 0.00%, max: 100.00%)	Displays the measured humidity demand of the humidifier.
	PowerOutput:	<i>Current value</i>	* (min: 0.00%, max: 100.00%)	Displays the measured power output of the system as a percentage of the total power.
	ServiceDue:	No	* (No, Yes)	Displays whether the humidifier is due for servicing.
	State:	<i>Current value</i>	* (Off, Idle, LineRinse, TankRinse, Filling, Draining, Heating, Boiling, Alarm)	Displays the current state of operation of the humidifier.
WtrProbeFail:	None	* (None, Capacitive, Resistive, Both)	Displays which one of the water level sensor's probes is currently not functioning properly.	
Control	RoomDemand:	<i>Current value</i>	* (min: 0.00%, max: 100.00%)	Displays the room humidity demand value. <b>(Only appears if ControlProfile is set to an internal control mode or HumCntrlDemandSrc is set to RoomDemand.)</b>
	SupplyHLDemand:	<i>Current value</i>	* (min: 0.00%, max: 100.00%)	Displays the supply high limit humidity demand value. <b>(Only appears if ModHLProfile is set to an internal control mode or HumCntrlHLSrc is set to SupplyHLDemand.)</b>
	HumDemand:	<i>Current value</i>	* (min: 0.00%, max: 100.00%)	Displays the current humidity demand value.
Physical IO	AirFlow:	Closed	* (Closed, Open)	Displays the status of the airflow switch. If <i>Open</i> is displayed, it indicates that the airflow is not detected by the air pressure switch.
	SupplyHighLimit:	Closed	* (Closed, Open)	Displays the status of the high limit contact. If <i>Open</i> is displayed, it indicates that the humidity level has exceeded the setpoint on the high limit humidistat.
	Interlock:	Closed	* (Closed, Open)	Displays the status of the interlock. If <i>Open</i> is displayed, it indicates that the humidifier is stopped as a result of the interlock safety being open.
	BinExtDemand:	0%	* (0%, 100%)	Displays whether there is currently a humidity demand, when an On/Off humidifier is used. <b>(Only appears when using an On/Off humidifier.)</b>
	ControllInput:	<i>Current value</i>	* (min: 0.00%, max: 100.00%)	Displays the current control input reading.
	RoomRH:	<i>Current value</i>	* (min: 0.00%, max: 100.00%)	Displays the room humidity reading value. <b>(Only appears if ControlProfile is set to InternAnalog or RoomRHSrc is set to RoomRH.)</b>
	SupplyHLRH:	<i>Current value</i>	* (min: 0.00%, max: 100.00%)	Displays the supply high limit humidity reading value. <b>(Only appears if ModHLProfile is set to InternAnalog or SupplyHLReadingSrc is set to SupplyHLRH.)</b>
	WtrLeakDet:	Ok	* (Ok, Leak)	Displays whether a water leak has been detected. If <i>Leak</i> is displayed, it indicates that there is a leak within the water line.
WtrLvLow:	<i>Current value</i>	* (Inactive, Active)	Displays the status of the resistive low water level sensor.	

Sub-Menu	Setting	Default	Range (* indicates no configuration; display only)	Description/Notes
<b>Physical IO</b>	WtrLvlHigh:	<i>Current value</i>	* (Inactive, Active)	Displays the status of the resistive high water level sensor.
	WaterTemp:	<i>Current value</i>	* (min: 0.00°C, max: 125.00°C) Units: C, F	Displays the temperature of water in the evaporation chamber.
	FoamSensor:	NoFoam	* (NoFoam, Foam)	Displays whether foam has been detected within the evaporation chamber. If <i>Foam</i> is displayed, it indicates that the Anti-Foaming Energy Conservation (AFEC) system has detected foam. The humidifier will drain for a few minutes and return to normal operation.
	ThermalCutout:	Closed	* (Closed, Open)	Displays the status of the thermal switch circuit on the PCB. If <i>Open</i> is displayed, it indicates that the wire has been incorrectly connected to the PCB.
	DrainValve:	<i>Current value</i>	* (Off, On)	Displays the status of the normally open drain valve. <b>(Only appears for units with weatherproof enclosure.)</b>
	CabinetTemp:	<i>Current value</i>	* (min: -20.00°C, max: 100.00°C) Units: C, F	Displays the temperature measured inside of the cabinet. <b>(Only appears for units with the weather proof enclosure.)</b>
	ContactorsFuse:	Normal	* (Normal, Blown Fuse)	Displays the current status of the PCB fuse. If <i>Blown Fuse</i> is displayed, the fuse must be replaced.
	PowerOutFdbck:	<i>Current value</i>	* (min: 0.00%, max: 100.00%)	Displays the feedback value of power output analog output.
	AlarmWarnRelay:	<i>Current value</i>	* (Off, On)	Displays the status of the alarm warning relay.
	ServiceWarnRelay:	<i>Current value</i>	* (Off, On)	Displays the status of the service warning relay.
	WtrLvlValve:	<i>Current value</i>	* (Off, On)	Displays the status of the water level sensor supply valve.
	TankWtrValve:	<i>Current value</i>	* (Off, On)	Displays the status of the evaporation chamber water supply valve.
	DrainCoolValve:	<i>Current value</i>	* (Off, On)	Displays the status of the internal drain cooler valve.
	DrainPump:	<i>Current value</i>	* (Off, On)	Displays the status of the first drain pump.
	SteamVlvCtrl:	<i>Current value</i>	* (min: 0.00%, max: 100.00%)	Displays the value of the control signal coming from the actuated steam valve.
	DrainPump2:	<i>Current value</i>	* (Off, On)	Displays the status of the second drain pump. <b>(Only appears for models having a second drain pump.)</b>
	DrainPump3:	<i>Current value</i>	* (Off, On)	Displays the status of the third drain pump. <b>(Only appears for models having a third drain pump.)</b>
	WaterLevel:	<i>Current value</i>	* (min: 0.0%, max: 120.0%)	Displays the percentage of water remaining in the evaporation chamber.
SteamValveFdbck:	<i>Current value</i>	* (min: 0.00%, max: 100.00%)	Displays the value of the feedback signal coming from the actuated steam valve.	
<b>System</b>	SysStatus:	Operational	* (Operational, Operational Read-Only, Download required, Download in progress, Non-operational, Backup in progress)	Displays the current system status.
	Vendor:	Neptronic	*	Displays the name of the vendor of the product. (Always Neptronic)
	Model:	-	*	Displays the humidifier model name.
	AppVersion:	2.00.20210114	*	Displays the current application software version.
	SerialNo:	-	*	Displays the serial number of the humidifier.
	Profile:	-	*	Displays a short profile for the configured device.
	MCULoad:	<i>Current value</i>	* (min: 0.0%, max: 100.0%)	Displays the current microcontroller load.
	MemoryLoad:	<i>Current value</i>	* (min: 0.0%, max: 100.0%)	Displays the current memory load.
	Runtime:	<i>Current value</i>	* (min: 0sec, max: 999999999sec)	Displays the number of seconds that the system has been powered on. This value is reset every time the system id shut off.
ResetReason:	None	* (None, BOR, Pin, POR, Soft, IWDG, WWDG, LPWR, Unknown)	Displays the reason for the previous system reset: <i>None = No Reset; BOR = Brownout Reset; Pin = Pin Reset (using PCB Reset Button); POR = Power-on Reset; Soft = Software Reset; IWDG = Independent Watchdog; WWDG = Windowed Watchdog; LPWR = Low Power Reset; Unknown = Unknown Cause</i>	

**Menu - User Settings** [Level 2 - Requires level 2 (or higher) password in order to access]

Sub-Menu	Setting	Default	Range	Description/Notes
<b>Command</b>	OccupSchedule:	-	00:00 Monday to Sunday Event 1 to Event 6	Create a customized occupancy schedule with up to six events per day.
<b>Control</b>	<b>RoomDemandLoop [3]</b>			<b>Only appears if <i>ControlProfile</i> is set to an internal control mode or <i>HumCntrlDemandSrc</i> is set to <i>RoomDemand</i>.</b>
	RoomRHStp:	40.0%	min: 0.0%, max: 100.0%	Define the room demand setpoint value used during <i>Occupied</i> state. <b>(Only appears if <i>RoomRHStptSrc</i> is set to <i>Internal</i>.)</b>
	RoomRHUnocStp:	30.0%	min: 0.0%, max: 100.0%	Define the room demand setpoint value used during <i>Unoccupied</i> state.
	RoomRHVacStp:	20.0%	min: 0.0%, max: 100.0%	Define the room demand setpoint value used during <i>Vacant</i> state.
	<b>SupplyHLLoop [1]</b>			<b>Only appears if <i>ModHLProfile</i> is set to an internal control mode or <i>HumCntrlHLSrc</i> is set to <i>SupplyHLDemand</i>.</b>
	SupplyHLStp:	80.0%	min: 0.0%, max: 100.0%	Define the supply high limit demand setpoint value.
<b>System</b>	UTCOffset:	-300min	min: -720min, max: 720min	Configure the value of the UTC offset.
	Daylight Savings:	No	No, Yes	Select whether to enable daylight savings or not.
	LocalDateTime:	YYYY-MM-DD 00:00:00		Configure the current date and time.
<b>Interface</b>	<b>Local Display [5]</b>			
	BacklightLvl:	25%	min: 0%, max: 100%	Select the backlight level of the LCD screen.
	Contrast:	10%	min: 0%, max: 30%	Select the contrast level of the LCD screen.
	KeypadBuzzer:	Inactive	Inactive, Active	Select whether to enable or disable the key press sound.
	Language:	English	English, French, Spanish	Select the device language.
	Units:	Metric	Metric, Imperial	Select whether to use a metric or imperial system of units for the local device.
	<b>HRL [3]</b>			<b>For units connected to the HRL24 controller.</b>
	Temperature:	<i>Current value</i>	* (min: -40.0°C, max: 260.0°C) Units: C, F	Displays the room temperature value measured by the HRL24 controller.
	Humidity:	<i>Current value</i>	* (min: 0.0%, max: 100.0%)	Displays the room humidity value measured by the HRL24 controller.
LockSetpnt:	Unlock	Unlock, Lock	Displays whether the setpoint obtained from the HRL24 controller can be modified or not.	

**Menu - Service** [Level 3 - Requires level 3 (or higher) password in order to access]

Sub-Menu	Setting	Default	Range <i>(* indicates no configuration; display only)</i>	Description/Notes
<b>Status</b>	RunTime:	0.00hr	*	Displays the total runtime of the unit.
	OnTime:	0.00hr	*	Displays the total operating time of the unit.
	ServRunTime:	0.00hr	*	Displays the runtime of the unit, since the last servicing.
	ServOnTime:	0.00hr	*	Displays the operating time of the unit, since the last servicing.
	ManCalibTime:	0.00hr	*	Displays the amount of time that has been elapsed since the last manual calibration of the water level sensor. <b>(Only appears if WtrAutoCalib is set to Off).</b>
	ServiceDue:	No	*(Yes, No)	Displays whether the humidifier is due for servicing.
<b>Command</b>	DrainSchedule:	-	00:00 Monday to Sunday Event 1 to Event 6	Create a customized draining schedule with up to six events per day.
	Request:	None	None, Reset Alarms, Drain, Reset Counters, Filling, WaterCalib	Perform one of the following actions for the humidifier: reset warning alarms, initiate a drain cycle, reset service counters, fill the evaporation chamber or calibrate the water level sensor.

**Menu - Installation** [Level 4 - Requires level 4 (or higher) password in order to access]

Sub-Menu	Setting	Default	Range (* indicates no configuration; display only)	Description/Notes	
<b>Import User Config</b>				Import all the controller configuration values onto the SD card. A SD card must be inserted in order to import the values.	
<b>Export User Config</b>				Export all the controller configuration values onto the SD card. A SD card must be inserted in order to export all the values.	
<b>Quick Config</b>	DrainInterval:	6hr	min: 0hr, max: 24hr	Set the frequency of the drain cycle. In general, a more frequent drain cycle is required as the water hardness level rises. The drain cycle setting does not affect the AFEC system.	
	IdleTime:	24hr	min: 0hr, max: 72hr	Set the amount of time the humidifier can remain in standby mode until an automatic drain cycle is performed.	
	BlowdownRate:	0%	min: 0%, max: 100%	Define the rate of boiler blowdown or water dilution, in order to minimize water impurities.	
	ServInterval:	1000hr	min: 1000hr, max: 3000hr	Set the time of operation before the humidifier calls for servicing.	
	ServOperation:	Allowed	Not Allowed, Allowed	Select whether to enable the unit to continue producing steam, even when it is due for servicing. When set to <i>Allowed</i> , the unit will continue operating even when a service alarm is active.	
	FillMode:	Pulsed	OneShot, Pulsed	Select the water filling method for the fill valve: When set to <i>OneShot</i> , water will continuously flow. When set to <i>Pulsed</i> , water will flow in short bursts.	
<b>Control</b>	ControlProfile:	ExternAnalog	ExternAnalog, ExternNetwork, InternAnalog, InternNetwork, HRL, Custom	Select a preconfigured control mode profile for the modulating humidity demand. Select the <i>Custom</i> option to configure individual settings. <b>(Network option only applicable for BACnet models.)</b>	
	ModHLPProfile:	Disabled	Disabled, ExternAnalog, ExternNetwork, InternAnalog, InternNetwork, Custom	Select a preconfigured control mode profile for the modulating high limit demand. Select the <i>Custom</i> option to configure individual settings. <b>(Network option only applicable for BACnet models.)</b>	
	<b>RoomDemandLoop [6]</b>				<b>Only appears if <i>ControlProfile</i> is set to an internal control mode or <i>HumCntrlDemandSrc</i> is set to <i>RoomDemand</i>.</b>
	RoomPropGain:	28.5	min: 1.0, max: 200.0	Set the value of the room demand proportional gain.	
	RoomIntgrlTime:	15.0sec	min: 0.0sec, max: 900.0sec	Set the value of the room demand integral time.	
	RoomDrvtveTime:	0.0sec	min: 0.0sec, max: 60.0sec	Set the value of the room demand derivative time.	
	RoomProbBand:	5.0%	min: 1.0%, max: 100.0%	Set the value of the room demand proportional band.	
	RoomRHSrc:	None	None, RoomRH, Network, HRL	Select the reading source for the room demand. <b>(Network option only applicable for BACnet models.)</b>	
	RoomRHStptSrc:	None	None, Internal, ControllInput	Select the room demand setpoint source.	
	<b>SupplyHLLoop [6]</b>				<b>Only appears if <i>ModHLPProfile</i> is set to an internal control mode or <i>HumCntrlHLSrc</i> is set to <i>SupplyHLDemand</i>.</b>
	SupplyHLPPropGain:	28.5	min: 1.0, max: 200.0	Set the value of the supply high limit demand proportional gain.	
	SupplyHLIntgrl:	15.0sec	min: 0.0sec, max: 900.0sec	Set the value of the supply high limit demand integral time.	
	SupplyHLDrvtveTime:	0.0sec	min: 0.0sec, max: 60.0sec	Set the value of the supply high limit demand derivative time.	
	SupplyHLProbBand:	10.0%	min: 1.0%, max: 100.0%	Set the value of the supply high limit demand proportional band.	
SupplyHLReadingSrc:	None	None, SupplyHLRH, Network	Select the reading source for the supply high limit demand. <b>(Network option only applicable for BACnet models.)</b>		
SupplyHLStptSrc:	None	None, Internal, ControllInput	Select the supply high limit demand setpoint source.		

Sub-Menu	Setting	Default	Range (* indicates no configuration; display only)	Description/Notes
Control	<b>HumidityControl [5]</b>			
	HumLowDeadBand:	1.00%	min: 0.00%, max: 100.00%	Set the lower limit deadband value for the humidity demand.
	NtwkTimeout:	900sec	min: 1sec, max: 900sec	Define the amount of time the humidifier may attempt to connect to the BACnet or Modbus network before it stops operating due to a communication error. <b>(Only appears if ControlProfile or ModHLProfile are set to InternNetwork or ExternNetwork.)</b>
	HumCntrlDemandSrc:	ControllInput	None, ControllInput, RoomDemand, Network	Select the humidity control demand source for modulating humidifiers. <b>(Network option only applicable for BACnet models.)</b>
	HumCntrlHLSrc:	None	None, ControllInput, SupplyHLDemand, Network	Select the humidity control high limit source for modulating humidifiers. <b>(Network option only applicable for BACnet models.)</b>
	HumCntrlBinDemandSrc:	None	None, BinaryExtDemand	Select the humidity control demand source for On/Off humidifiers.
Physical IO	<b>ControllInput [6]</b>			
	Signal:	0.000V	* (min: 0.000V, max: 15.000V)	Displays the value of the control demand analog input signal.
	ControllInput:	0.00%	* (min: 0.00%, max: 100.00%)	Displays the actual value of the control demand analog input.
	Min:	0.00%	min: 0.00%, max: 100.00%	Set the minimum value of the control demand analog input.
	Max:	100.00%	min: 0.00%, max: 100.00%	Set the maximum value of the control demand analog input.
	Bias:	0.00%	min: -10.00%, max: 10.00%	Set the bias value for the control demand analog input.
	SignalType:	0-10Vdc	0-10Vdc, 2-10Vdc, 4-20mA, 0-20mA	Select the signal type for the control demand analog input.
	<b>RoomRH [7]</b>			
	Signal:	0.000V	* (min: 0.000V, max: 15.000V)	Displays the value of the room humidity analog input signal.
	RoomRH:	0.00% RH	* (min: 0.00% RH, max: 100.00% RH)	Displays the actual value of the room humidity analog input.
	Min:	0.00% RH	min: 0.00% RH, max: 100.00% RH	Set the minimum value of the room humidity analog input.
	Max:	100.00% RH	min: 0.00% RH, max: 100.00% RH	Set the maximum value of the room humidity analog input.
	Bias:	0.00% RH	min: -10.00% RH, max: 10.00% RH	Set the bias value for the room humidity analog input.
	AlwaysShow:	On	Off, On	Select whether to always display the RoomRH setting, regardless of the configuration selected in the ControlProfile setting.
	SignalType:	0-10Vdc	0-10Vdc, 2-10Vdc, 4-20mA, 0-20mA	Select the signal type for the room humidity analog input.
	<b>SupplyHighLimRH [7]</b>			
	Signal:	0.000V	* (min: 0.000V, max: 15.000V)	Displays the value of the duct or supply high limit humidity analog input signal.
	SupplyHLRH:	0.00% RH	* (min: 0.00% RH, max: 100.00% RH)	Displays the actual value of the duct or supply high limit humidity analog input.
	Min:	0.00% RH	min: 0.00% RH, max: 100.00% RH	Set the minimum value of the duct or supply high limit humidity analog input.
	Max:	100.00% RH	min: 0.00% RH, max: 100.00% RH	Set the maximum value of the duct or supply high limit humidity analog input.
	Bias:	0.00% RH	min: -10.00% RH, max: 10.00% RH	Set the bias value for the duct or supply high limit humidity analog input.
	AlwaysShow:	On	Off, On	Select whether to always display the SupplyHLRH setting, regardless of the configuration selected in the ModHLProfile setting.
	SignalType:	0-10Vdc	0-10Vdc, 2-10Vdc, 4-20mA, 0-20mA	Select the signal type for the duct or supply high limit humidity analog input.
	WtrLvlSig:	0Hz	* (min: 0.000V, max: 30000V)	Displays the value of the water level feedback signal.



Sub-Menu	Setting	Default	Range (* indicates no configuration; display only)	Description/Notes	
Physical IO	WtrLvlLowSig:	0.000V	* (min: 0.000V, max: 10.000V)	Displays the value of the resistive low water level sensor signal.	
	WtrLvlHiSig:	0.000V	* (min: 0.000V, max: 10.000V)	Displays the value of the resistive high water level sensor signal.	
	<b>WaterTemp [3]</b>				
	WtrTempSig:	0.000V	* (min: 0.000V, max: 10.000V)	Displays the value of the water temperature sensor signal.	
	WaterTemp:	122.0°F [50.0°C]	* (min: 32.0°F, max: 257.0°F) * [min: 0.0°C, max: 125.0°C] Units: C, F	Displays the temperature of water in the evaporation chamber.	
	WaterTempBias:	0.00Δ°F [0.00Δ°C]	min: -18.00Δ°F, max: 18.00Δ°F [min: -10.00Δ°C, max: 10.00Δ°C] Units: Δ°C, Δ°F	Set the bias value for the water temperature sensor.	
	FoamSig:	0.000V	* (min: 0.000V, max: 10.000V)	Displays the value of the foam sensor signal.	
	<b>CabinetTemperature [3]</b>				<b>Only appears for units with the weather proof enclosure.</b>
	CabTempSig:	0.000V	* (min: 0.000V, max: 10.000V)	Displays the value of the cabinet interior temperature sensor signal.	
	CabinetTempBias:	0.00Δ°F [0.00Δ°C]	min: -18.00Δ°F, max: 18.00Δ°F [min: -10.00Δ°C, max: 10.00Δ°C] Units: Δ°C, Δ°F	Set the bias value for the cabinet interior temperature sensor.	
	CabinetTemp:	32.0°F [0.0°C]	* (min: -4.0°F, max: 212.0°F) * [min: -20.0°C, max: 100.0°C] Units: C, F	Displays the temperature measured inside of the cabinet.	
	<b>SteamOutFdbck [5]</b>				
	Signal:	0.000V	* (min: 0.000V, max: 10.000V)	Displays the value of the power output feedback signal.	
	Bias:	0.000V	min: -1.000V, max: 1.000V	Set the bias value for the power output feedback signal.	
	Min:	0.000V	min: 0.000V, max: 10.000V	Set the minimum value of the power output feedback signal.	
	Max:	0.000V	min: 0.000V, max: 10.000V	Set the maximum value of the power output feedback signal.	
	PowerOutFdbck:	0.00%	* (min: 0.00%, max: 100.00%)	Displays the value of the power output feedback.	
	<b>WaterProbe [4]</b>				<b>Only appears if WtrAutoCalib is set to Off.</b>
	LowPosReading:	0Hz	* (min: 0Hz, max: 30000Hz)	Displays the low position value of the water level sensor.	
	HighPosReading:	0Hz	* (min: 0Hz, max: 30000Hz)	Displays the high position value of the water level sensor.	
AbsLowPosReading:	0Hz	* (min: 0Hz, max: 30000Hz)	Displays the absolute low position value of the water level sensor.		
AbsHighPosReading:	0Hz	* (min: 0Hz, max: 30000Hz)	Displays the absolute high position value of the water level sensor.		
System	ResetFactory:	No	No, Yes	Select Yes in order to reset the humidifier back to its original factory configuration settings. <b>WARNING: There is no way to recover previous configurations once the device has been reset.</b>	
Extended Config	InstallationDate:	YYYY/MM/DD		Set the device installation date.	
	AlarmBuzzer:	Disabled	Normal, Disabled	Select whether to enable or disable the alarm buzzer sound whenever there is a system warning. This will not affect the Status Display LED.	
	SysLogLevel:	Debug	None, Emergency, Alert, Critical, Error, Warning, Notice, Info, Debug	Select the type of information to be stored on log file. <b>(The humidifier must be connected to an SD card.)</b>	
	WtrLvlReplace:	7day	Min: 0day, max: 7day	Set the amount of time the humidifier may run using only the resistive water level probes, if there is an issue with the capacitive probe, before an alarm message is displayed.	
	MinSteamOut:	5%	min: 1%, max: 25%	Set the minimum steam production demand value, below which no steam will be produced.	

Sub-Menu	Setting	Default	Range (* indicates no configuration; display only)	Description/Notes
<b>Extended Config</b>	DrainInterval:	6hr	min: 0hr, max: 24hr	Set the frequency of the drain cycle. In general, a more frequent drain cycle is required as the water hardness level rises. The drain cycle setting does not affect the AFEC system.
	DrainVolume:	100%	min: 25%, max: 100%	Define the volume of water that is drained from the chamber, relative to the total capacity of the chamber.
	MaxOutput:	100%	min: 0%, max: 100%	Set the maximum steam output of the humidifier relative to its total capacity. <b>(Only applicable for modulating humidifiers.)</b>
	IdleTime:	24hr	min: 0hr, max: 72hr	Set the amount of time the humidifier can remain in standby mode until an automatic drain cycle is performed.
	IdleTempStpnt:	0°C	min: 0°C, max: 60°C Units: C, F	Set the idle temperature setpoint value for the evaporation chamber when there is no demand.
	BlowdownRate:	0%	min: 0%, max: 100%	Define the rate of boiler blowdown or water dilution, in order to minimize water impurities.
	ServInterval:	1000hr	min: 1000hr, max: 3000hr	Set the time of operation before the humidifier calls for servicing.
	IdleRinseInterval:	3day	min: 1day, max: 7day	Set the amount of time the humidifier stays in "Idle" or "Off" mode, before the evaporation chamber undergoes an automatic rinse cycle.
	ActrDeadband:	5%	min: 0%, max: 25%	Set the deadband value for the steam actuated valve.
	ServOperation:	Allowed	Not Allowed, Allowed	Select whether to enable the unit to continue producing steam, even when it is due for servicing. When set to <i>Allowed</i> , the unit will continue operating even when a service alarm is active.
	PwrUpDrain:	Off	Off, On	Select whether to enable an automatic draining cycle each time the humidifier is powered on.
	FillMode:	Pulsed	OneShot, Pulsed	Select the water filling method for the fill valve: When set to <i>OneShot</i> , water will continuously flow. When set to <i>Pulsed</i> , water will flow in short bursts.
	IdleRinseOn:	Off	Off, On	Select whether to enable automatic rinse cycles while the humidifier is turned on and remains in "Idle" or stand-by mode. To select the amount of time the humidifier remains inactive before a rinse cycle is performed, configure the value of the <i>IdleRinseInterval</i> setting.
	IdleRinseOff:	Off	Off, On	Select whether to enable automatic rinse cycles while the humidifier is turned off and remains inactive. To select the amount of time the humidifier remains inactive before a rinse cycle is performed, configure the value of the <i>IdleRinseInterval</i> setting.
	WtrAutoCalib:	On	On, Off	Select whether to enable or disable the automatic calibration of the water level sensor.
StartupRinse:	Off	Off, On	Select whether to perform an automatic rinse cycle upon each start-up of the humidifier.	

**Menu - Integration** [Level 5 - Requires level 5 password in order to access]

Sub-Menu	Setting	Default	Range (* indicates no configuration; display only)	Description/Notes
<b>Network</b>	NtwrkOption:	BACnet	BACnet, Modbus	Select whether to connect to a BACnet MS/TP or Modbus RTU communication interface on terminal TB2 of the humidifier PCB.
	<b>Device [4]</b>			
	DeviceName:	-		Establish a name for the device.
	Location:	-		Establish a designated location for the unit.
	Description:	-		Establish a brief description for the unit.
	DeviceInstance:	0153001 (0x000255a9)		Define the device instance value.
	<b>HTTPServer [1]</b>			
	HttpServerUnits:	Metric	Metric, Imperial	Select whether to use a metric or imperial system of units for the HTTP server.
	<b>BACnetServer [3]</b>			
	Language:	English	English, French, Spanish	Select the language for the BACnet server.
	ListMode:	Integrator	Integrator, Advanced, Factory	Select the category of BACnet objects to display.
	Units:	Metric	Metric, Imperial	Select whether to use a metric or imperial system of units for the BACnet server.
	<b>BACnetMSTP [10]</b>			
	MaxMaster:	127	min: 1, max: 127	Configure MaxMaster value to increase network efficiency when there are less than 127 devices on the network. For optimal efficiency, set value to the highest MAC address in the MS/TP network.
	MaxInfoFrames:	1	min: 1, max: 100	Configure the maximum number of information messages the controller may transmit, before it must pass the token to the next controller.
	AutoBaud:	Yes	No, Yes	Enable or disable automatic baud rate detection.
	BaudRate:	38400	9600, 19200, 38400, 76800	Select the baud rate for data transfer.
	MAC:	001		Set the MS/TP network MAC address.
	RxValid:	0	*	Displays information on the received communication frames for troubleshooting purposes.
	RxInvalid:	0	*	
	RxLost:	0	*	
	Tx:	0	*	Displays information on the transmitted frames for troubleshooting purposes.
	TxLost:	0	*	
	<b>BACnetIP [6]</b>			
	RxValid:	0	*	Displays information on the received communication frames for troubleshooting purposes.
	RxInvalid:	0	*	
	RxLost:	0	*	
Tx:	0	*	Displays information on the transmitted frames for troubleshooting purposes.	
TxLost:	0	*		
BACnetIPPort:	47808	min: 0, max: 65535	Set the User Datagram Protocol (UDP) port number. BACnet port number is set by default.	

Sub-Menu	Setting	Default	Range (* indicates no configuration; display only)	Description/Notes
Network	<b>ModbusServer [1]</b>			<b>For models connected to Modbus.</b>
	Units:	Metric	Metric, Imperial	Select whether to use a metric or imperial system of units for the Modbus server.
	<b>ModbusRTU1In [4]</b>			<b>Only appears if <i>NtwrkOption</i> is set to <i>Modbus</i>.</b>
	MAC:	1	min: 1, max: 247	Set the Modbus MAC address.
	Autobaud:	Yes	No, Yes	Enable or disable automatic baud rate detection.
	PortConfig:	No Parity, 2 Stop Bits	No Parity, 2 Stop Bits Even Parity, 1 Stop bit Odd Parity, 1 Stop bit	Select the Modbus communication port configuration.
	BaudRate:	19200	9600, 14400, 19200, 38400, 57600	Select the baud rate for data transfer.
	<b>ModbusTCPiPoln [2]</b>			<b>For models connected to Modbus TCP/IP</b>
	KeepAliveTimeOut:	5min	min: 1min, max: 1440min	Set the amount of time the communication stays open before connection is cut out, when no signal is received from the device.
	Listening Port:	502	min: 0, max: 65535	Set the communication port number. Modbus TCP port number is set by default.
	<b>SMTP [7]</b>			
	SSL:	Off	Off, On	If turned to <i>On</i> , a secure socket layer will be used to encrypt the communication between the device and the email server (Port value must be set to 587 and <i>Username</i> and <i>Password</i> settings must be filled out). If turned to <i>Off</i> , the default socket will be used (use Port 25 to use server without login account or Port 587 if login details for email account have been entered).
	Port:	25	25, 587	If set to 25, server to server email transfer is enabled (can only be used if SSL is set to <i>Off</i> ). If set to 587, client to server email transfer is enabled.
	ServerAddr:	192.168.100.100		Configure the server IP address for the email account.
	From:	<i>Current value</i>		Set the email address that will be sending the humidifier notification messages.
	To:	<i>Current value</i>		Set the email address that will be receiving the humidifier notification messages.
	Username:	<i>Current value</i>		Set the login username for the email account.
	Password:	<i>Current value</i>		Set the login password for the email account.
	<b>Notify [3]</b>			
	Alarm:	Off	Off, On	If turned to <i>On</i> , then the humidifier alarm messages will be sent to the email configured in the <i>SMTP</i> sub-menu.
	Warning:	Off	Off, On	If turned to <i>On</i> , then the humidifier warning messages will be sent to the email configured in the <i>SMTP</i> sub-menu.
	AppMsg:	Off	Off, On	If turned to <i>On</i> , then the humidifier event messages will be sent to the email configured in the <i>SMTP</i> sub-menu.
	<b>BACnetETH [5]</b>			<b>For models connected to BACnet Ethernet.</b>
RxValid:	0	*	Displays information on the received communication frames for troubleshooting purposes.	
RxInvalid:	0	*		
RxLost:	0	*		
Tx:	0	*	Displays information on the transmitted frames for troubleshooting purposes.	
TxLost:	0	*		

Sub-Menu	Setting	Default	Range (* indicates no configuration; display only)	Description/Notes
Communication	<b>IPSettings [10]</b>			
	DHCP:	Inactive	Inactive, Active	Select whether to enable Dynamic Host Configuration Protocol (DHCP) to automatically provide an IP address.
	RstIPSetting:	No	No, Yes	Select whether to restart the IP module, in order to allow recent parameter modifications to be effective.
	StaticAddress:	192.168.1.100		Configure the static IP address.
	StaticSubnetMask:	255.255.255.0		Configure the static subnet mask.
	StaticDefaultGateway:	192.168.0.100		Configure the static default gateway.
	StaticDnsServer:	192.168.10.50		Configure the static DNS server.
	ActualAddress:	<i>Current value</i>	*	Displays the actual IP address.
	ActualSubnetMask:	<i>Current value</i>	*	Displays the actual subnet mask.
	ActualDefaultGateway:	<i>Current value</i>	*	Displays the actual default gateway.
	ActualDnsServer:	<i>Current value</i>	*	Displays the actual DNS server.
<b>ETHSettings [1]</b>				
EthernetMacAdd:	<i>Current value</i>	*	Displays the MAC address of the Ethernet interface. <b>(Only applicable if using an Ethernet connection.)</b>	



## List of Alarms

Table 12 - List of Alarms

Display	Description	Alarm Reset
AirFlow	Indicates that the airflow sensor is open. Verify that the signal from the airflow sensor is present at the controller's input on the PCB and verify wiring.	Automatic
SupplyHighLimit	Indicates that the high limit item is open. Verify that the signal from the supply high limit sensor is present at the controller's input on the PCB and verify wiring.	Automatic
Interlock	Indicates that the interlock and the cut-out circuitry are open. Verify that the signal from the interlock sensor is present at the controller's input on the PCB and verify wiring.	Automatic
HighLimitCutout	Indicates that the high limit cutout has been activated due to a humidity reading that exceeds the high limit setpoint. Ensure that the high limit humidistat is operating correctly and that the distance between the sensor and the steam dispersion manifold is sufficient (4.6 m).	Automatic
ThermalCutout	Indicates that the thermal switch circuit is open. Verify that the wire going to the thermal switch connection on the PCB is properly connected.	Automatic
WtrLvlLow	Indicates that the resistive low water level sensor is defective or incorrectly wired. Check sensor and verify wiring.	Automatic
WtrLvlHigh	Indicates that the resistive high water level sensor is defective or incorrectly wired. Check sensor and verify wiring.	Automatic
WaterTemp	Indicates that the evaporation chamber water temperature sensor is defective or incorrectly wired. Check sensor and verify wiring.	Automatic
CabinetTemp	Indicates that the cabinet temperature sensor is defective or incorrectly wired. Check sensor and verify wiring. (Only applicable for humidifiers having the weatherproof option.)	Automatic
FoamSensor	Indicates that the foam cutout sensor is defective or incorrectly wired. Check sensor and verify wiring.	Automatic
ContactorsFuse	Indicates that there is an issue with the printed circuit board fuse. Check the status of the fuse and replace it if defective.	Automatic
MemoryCard (Warning)	Indicates that the SD card has been detected, but it is not operating correctly or is non-functional. Verify the SD card and replace if defective.	Automatic
USB Device (Warning)	Indicates that the USB device has been detected, but it could not be read or is not operating correctly. Verify the functionality of USB device and replace if defective.	Automatic
Foam (Warning)	If <i>Detected</i> is displayed, it indicates that the foam sensor has detected foam and the humidifier is now draining. Once the drain cycle has ended, the warning message will disappear.	Automatic
ManWtrCalib (Warning)	Indicates that the water level sensor must be manually calibrated. See Manual Water Level Calibration section on page 55 for details. (Only applicable if <i>WtrAutoCalib</i> is set to <i>Off</i> .)	Automatic
WaterLevel (Warning)	If <i>Calib</i> is displayed, it indicates that there is a calibration error with the water level sensor. Verify that the <i>WtrAutoCalib</i> setting is set to <i>On</i> to ensure automatic calibration. If <i>Replace</i> is displayed, it indicates that the capacitive water level probe has drifted and the resistive probes have been activated until the capacitive probe is recalibrated. If the error persists, the warning message will change into the alarm message described below.	Automatic
WaterLevel (Alarm)	If <i>Defect</i> is displayed, it indicates that the water level sensor is defective or not working properly. Verify its operation and replace it if necessary. If the sensor is replaced, the humidifier will need to be turned on while there is a humidity demand in order to recalibrate the water level sensor. If <i>NoCalib</i> is displayed, it indicates that the water level sensor is not calibrated or must be recalibrated. Ensure that <i>WtrAutoCalib</i> is set to <i>On</i> for automatic calibration. If <i>WtrAutoCalib</i> has been changed to <i>Off</i> , ensure that the water level sensor has been manually calibrated.	Manual *
FailedPump	Indicates that there was an error during draining due to a pump failure. Verify that the drain pump is operating correctly and that it is not being hindered or obstructed.	Manual *
FillTimeout	Indicates that the water level sensor has not reached the desired value within the programmed delay. Verify and remove any obstructions in the water inlet line and verify that the shut-off valve is not closed.	Manual *
BlockedPiping	Indicates that there was an error during draining due to a blockage in the pipes. Verify and remove any obstructions in the piping and ensure that the drain outlet is not clogged.	Manual *
HeatTimeout	Indicates that the water temperature in the evaporation chamber has not reached the boiling point within the programmed delay. Verify the temperature of the supply water.	Manual *
Overheat	Indicates that the evaporation chamber temperature sensor has detected a temperature reading greater than or equal to 105°C. Verify the operation of the water level sensor and ensure that the water supply piping is not obstructed.	Manual *
WaterLeak	Indicates that a water leak has been detected. Verify the water line for signs of leaks and ensure that all piping and water connections have been properly installed and secured.	Manual *
TankBlocked	Indicates that there was an error while filling the evaporation chamber due to a blockage in the pipes. Verify and remove any obstructions in the piping and ensure that the water inlet is not clogged.	Manual *
RefillDelay	Indicates that the evaporation chamber has not been refilled with more water within the programmed delay after it has begun evaporating, due to a blockage in the pipes. Verify and remove any obstructions in the piping and ensure that the water inlet is not clogged.	Manual *
NtwkCtrlSt	Indicates that the communication attempt to the BMS server has exceeded the delay defined by the <i>Network Timeout</i> setting. Verify the wiring between the humidifier and the BACnet or Modbus network and ensure proper connection. (Only applicable for humidifiers having the BACnet or Modbus option).	Manual *



Display	Description	Alarm Reset
HRLState	Indicates that there is a communication error when attempting to connect to the HRL24 controller. Verify the wiring between the humidifier and the HRL24 and ensure that the controller is functioning properly. (Only applicable for humidifiers connected to the HRL24 controller).	Manual *
ServiceDue	Indicates that the due date for servicing the humidifier has arrived. See Service section on page 59 for details.	Manual **

\* Use *Reset Alarms* function in *Request* setting (see page 45).

\*\* Use *Reset Counters* function in *Request* setting (see page 45).



## Manual Water Level Calibration

If the humidifier is not equipped with the pure DI humidifier option and uses ultrapure water, the water level sensor must be manually calibrated to obtain a more accurate sensor reading. To turn off the automatic calibration of the water level sensor, access the *WtrAutoCalib* setting located in the *Extended Config* sub-menu of the *Installation* menu and set its value to *Off*. Once this is done, the water level sensor will need to be manually calibrated by using the following steps:

1. To view the water level sensor, remove the front access panel.
2. To begin the manual water level calibration process, access the Request settings located in the *Command* sub-menu of the *Service* menu, and set its value to *WaterCalib*.

**Step 1.** The water level sensor will then initiate a drain cycle. Wait until it has finished draining. The draining process can be stopped at any time by pressing and holding Enter ✓ for 3 seconds.

**Step 2.** Verify that no water remains in the water level sensor and press and hold Enter ✓ for 3 seconds to proceed. If the water has not been drained completely, open the manual drain valve to remove the remaining water.

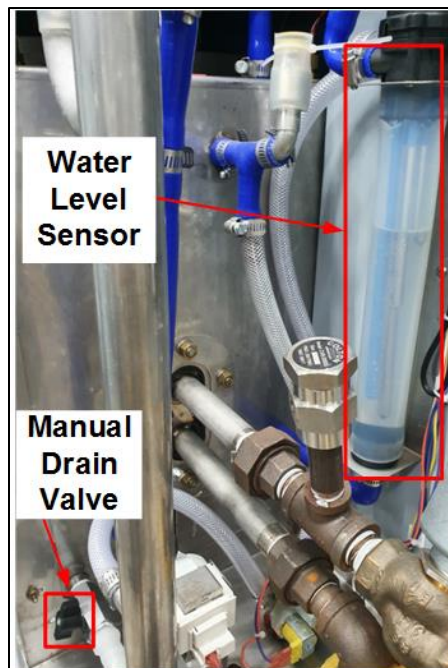

**Step 3.** The water level sensor will then start filling until it reaches the resistive low probe. The automatic filling process can be stopped at any time by pressing and holding Enter ✓ for 3 seconds.

**Step 4.** Once the *Low level* message appears on the controller, verify that the water has reached the resistive low water level probe.

- If the water has not reached the resistive low water level probe, use the + button to resume filling.
- If the water level sensor has been overfilled, open the manual drain valve to remove the additional water.
- Once the water has reached the resistive low probe, press and hold Enter ✓ for 3 seconds to proceed.



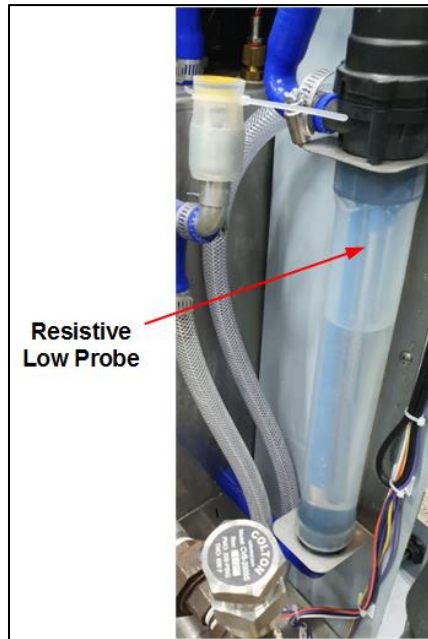

**Step 5.** The water level sensor will then start filling until it reaches the resistive high probe. The automatic filling process can be stopped at any time by pressing and holding Enter ✓ for 3 seconds.

**Step 6.** Once the *High level* message appears on the controller, verify that the water has reached the resistive high water level probe.

- If the water has not reached the resistive high water level probe, use the + button to resume filling.
- If the water level sensor has been overfilled, open the manual drain valve to remove the additional water.
- Once the water has reached the resistive high probe, press and hold Enter ✓ for 3 seconds to proceed.

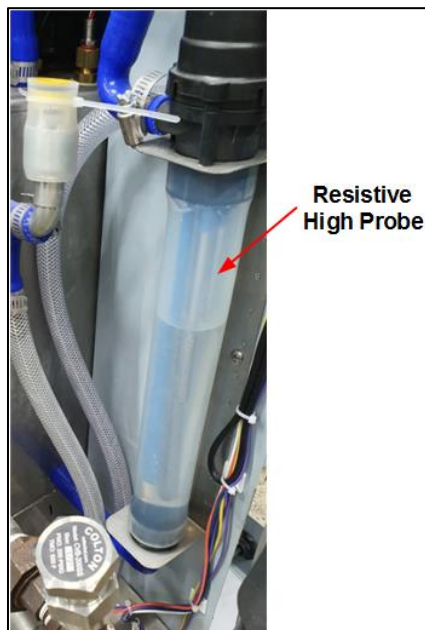

3. The manual water level calibration process is now complete.

# Start-up Procedure

---



**Initial verification and start-up must be carried out by suitably qualified personnel.**

It is strictly recommended to follow this start-up procedure in order to avoid any anomaly resulting from inaccurate installation of the components.

## Initial Verification

<b>Clearance</b>	1. Ensure that the humidifier cabinet is installed in a location in which the humidifier can be serviced correctly.	<input type="checkbox"/>
<b>Electrical Supply</b>	2. Verify that the power supply (voltage) conforms to the appliance name plate on the side of the humidifier.	<input type="checkbox"/>
	3. Confirm that 24Vac is present between terminals TB4 1&2 on the printed circuit board.	<input type="checkbox"/>
<b>Water Supply</b>	4. Ensure that water is supplied to the humidifier and that a shutoff valve is placed outside the humidifier.	<input type="checkbox"/>
	5. With the water shutoff valve turned on, check that the drain connections are connected to the main drain line with sufficient diameter. Ensure that there are no apparent leaks.	<input type="checkbox"/>
	6. Confirm that the drain piping is properly connected with a pitch of at least 6.5mm per 300mm.	<input type="checkbox"/>
<b>Clean Steam</b>	7. Verify that the steam distributors are properly installed into the ventilation duct.	<input type="checkbox"/>
	8. Verify that the flexible steam hoses and rigid steam supply pipes are shorter than 5 m in total, are properly sloped and have condensation "S" traps wherever required.	<input type="checkbox"/>
<b>Raw Steam or HTHW Supply</b>	9. Confirm that raw steam or HTHW is supplied to the humidifier and that the supply line is hot upstream the control valve. The pressure must not exceed 15 PSI (103.4 kPa) for SLP models.	<input type="checkbox"/>
	10. Confirm that the shut-off valve located outside the humidifier is closed. With the shut-off valve turned on, check for leaks or hissing sounds.	<input type="checkbox"/>
	11. When using raw steam supply, verify the type and size of the condensate return steam trap. The steam trap must be of float type and of sufficient dimension, according to the capacity.	<input type="checkbox"/>
	12. Ensure that the control valve is properly connected to the output control signal of the humidifier.	<input type="checkbox"/>
	13. Ensure that the Airflow switch is properly installed and connected to the printed circuit board. If an Airflow switch is not used, verify that a jumper is connected between terminals TB3 1&2.	<input type="checkbox"/>
	14. Ensure that the High limit duct humidistat is properly installed and connected to the printed circuit board. Verify that the setpoint is properly adjusted. If a High limit duct humidistat is not used, verify that a jumper is connected between terminals TB3 1&3.	<input type="checkbox"/>
<b>Controls</b>	15. Ensure that the Interlock is properly connected to the printed circuit board. If the Interlock is not used, verify that a jumper is connected between terminals TB3 1&4.	<input type="checkbox"/>
	16. If a room or duct humidistat is used, verify that it is correctly installed and properly connected to the humidifier. Verify that the setpoints are properly adjusted.	<input type="checkbox"/>
	17. Turn the power on using the disconnect switch or circuit breaker.	<input type="checkbox"/>
	18. Confirm the control set-up of the humidifier and verify that the setpoints are properly adjusted.	<input type="checkbox"/>



## Start-Up

---

**Start-up**

1. Proceed to start-up the humidifier, as follows:
  - a) Turn on the humidifier by pressing and holding the Power button  for 3 seconds. Verify that the controller Status Display LED is blue.
  - b) Verify that there is a humidity demand displayed on the LCD screen of the humidifier.
  - c) Ensure that the water supply valve connected to the humidifier is turned on and that water is flowing directly to the humidifier water supply inlet. Ensure that the water shut off valve is turned off.
  - d) Verify the water level as water is filling the evaporation chamber by using the control panel to access the *WaterLevel* setting located in the *Physical IO* sub-menu of the *General* menu. Ensure that there are no water leaks along the water line.
  - e) Once the evaporation chamber has been filled, observe the system for water and steam leaks during several minutes of operation.



---

**Safety Test**

2. Check the location of the Airflow switch in the system and its operation by stopping the fan. With no air movement, the humidifier should automatically stop.

---

**Drain and Reset**

3. Turn off the humidifier by pressing and holding the Power  button for 3 seconds.
4. Conduct a drain cycle by pressing and holding the Drain button  for 3 seconds. Ensure that the evaporation chamber has been emptied.
5. Once the drain cycle is complete, restart the humidifier by pressing and holding the Power  button for 3 seconds.
6. Reset the Airflow switch if needed.

---

**End**

7. The humidifier is now ready for normal operation.
-

## Service

---



**WARNING: Danger of hot water. Drain water before servicing.**

The humidifier requires regular periodic service to ensure efficient and trouble-free running. Regular service involves manually cleaning the humidifier and the strainer located on the steam line. Generally, frequency of cleaning can range from two months to once a year, depending on the following factors:

- Quality of water
- Frequency of automatic drain cycles
- Demand placed on the humidifier

All SKS4 humidifiers are programmed for 1000 hours of operation. This is a default factory setting.

To view the number of hours the humidifier has run and the number of service hours, use the control panel to access the *Service Menu* (see page 45 for more details).

After 1000 hours of operation have passed, the Status Display LED on the control panel will turn red, indicating that the humidifier is due for servicing. Although the humidifier will continue to operate, it is imperative that service is performed as soon as possible, in order to ensure proper functionality.

## Cleaning the Humidifier

Cleaning the humidifier involves the following steps:

**Stage 1 - Drain the Evaporation Chamber**

**Stage 2 - Shut Down the Electrical Supply**

**Stage 3 - Disassemble the Humidifier**



**Stage 4 - Clean the Components**

**Stage 5 - Reassemble the Humidifier**

**Stage 6 - Restart the Humidifier**

### Stage 1 - Drain the Evaporation Chamber

Before commencing the cleaning procedure, ensure that the evaporation chamber is cool and comfortable enough to handle, as the evaporation chamber and its contents can be extremely hot and can cause burning. To allow the evaporation chamber to cool, initiate a drain cycle:

1. Press and hold the Power  button for 3 seconds to switch off the humidifier.
2. Press and hold the Drain button  for 3 seconds to initiate a drain cycle and empty the evaporation chamber.

### Stage 2 - Shut Down the Electrical Supply



**CAUTION: Risk of electric shock. The electric supply of the humidifier must be shut down. Disconnect the power at the External Breaker/Fused Disconnect before commencing servicing.**

Once the drain cycle is complete, remove the power supply to the humidifier at the disconnect switch or the breaker.



### Stage 3 - Disassemble the Humidifier

1. Remove the painted top cover by manually turning the two thumb screws located on each side of the humidifier.
2. Remove the second cover made of stainless steel, by using the wrench found underneath the top cover (supplied) in order to remove the nuts connected to the stainless steel cover.
3. Remove both scale pans from the humidifier.

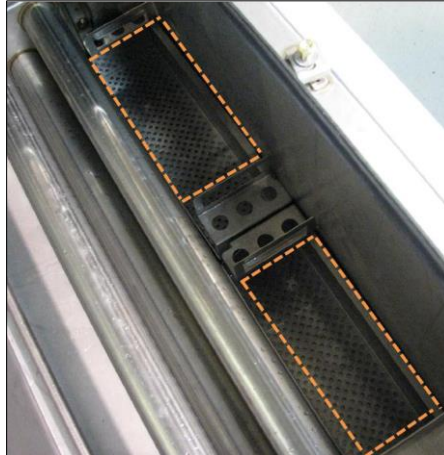

Illustration 47 - Removal of Scale Pans

### Stage 4 - Clean the Components

1. Clean the scale pans and the evaporation chamber:
  - Empty out all accumulated scale build-up from the scale pans and remove the residue that has accumulated inside the chamber.
  - To clean out any remaining scale, use a stiff brush (synthetic filament only) and some vinegar or any weak acid suitable for cleaning stainless steel.



**WARNING: The use of a wire brush or any non-recommended acid will void the warranty.**

- Do not scrape off the walls of the scales pans or the evaporation chamber.
  - Ensure that the water inlet aperture is not blocked.
2. Remove the excess water using the manual drain valve, in order to clean the scale pan area.
  3. Close the manual drain valve.

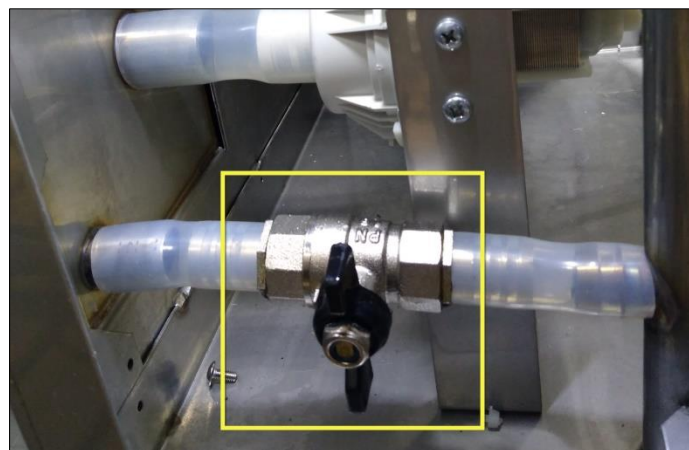







Illustration 48 - Manual Drain Valve



### Stage 5 - Reassemble the Humidifier

1. Reinstall both scale pans. Ensure that the drain hole remains free from any obstruction.
2. Close the stainless steel cover using the wrench (supplied) and ensure that it is tightened properly to prevent steam loss.
3. Close the painted top cover by turning the four thumb screws.
4. Turn the power back on at the disconnect switch or the breaker.

### Stage 6 - Restart the Humidifier

1. Press and hold the Power  button for 3 seconds to power on the humidifier.
2. Conduct a performance test by verifying the water level of the evaporation chamber as it is filled with water. Verify that there are no leaks.
3. Conduct a drain test by turning off the humidifier using the Power  button and performing a drain cycle using the Drain button .
4. Restart the humidifier to resume normal operation by pressing and holding the Power  button for 3 seconds.
5. To reset the service counters and clear the alarm warning after servicing:
  - a. Using the control panel, access the *Request* setting located in the *Command* sub-menu of the *Service* menu.
  - b. Select the *Reset Counters* value and press Enter  to reset the service counters.
6. Ensure that the drain cycles are set for every 6 hours of operation. This is the factory default setting and is recommended for city water.
  - To configure the drain cycle frequency, use the control panel to access the *DrainInterval* setting located in the *Quick Config* or *Extended Config* sub-menus of the *Installation* menu.

After the water boils for 6 hours in the chamber, it is laden with minerals and solutions. This affects the humidity output and the efficiency of the humidifier. Diluting the boiling water with a drain cycle will improve the performance of the humidifier.

## Strainer Maintenance

Perform the following steps for strainer maintenance:

1. Turn off the steam supply coming to the strainer on the steam supply pipe.
2. Unscrew the meshing cap.



Illustration 49 - Meshing Cap

3. Clean the meshing cap by removing any debris located inside of it.
4. Reassemble the meshing in the strainer body using the cap.
5. Reopen the steam supply on the steam supply line.

# Troubleshooting

Table 13 - Troubleshooting Guide

<b>Problem</b>	<b>Possible Cause</b>	<b>Corrective Action</b>
<i>Humidifier does not operate (Screen turned Off)</i>	Power is not being supplied to the humidifier.	Check the main power supply and fuses. Verify the disconnect switch and the circuit breaker.
	The low voltage fuse is open.	Check the transformer and the low voltage fuse. Verify that the low voltage circuit is complete.
	Wire harnesses inside the humidifier are not secured properly.	Check the wires harnesses and the main PC board. Verify that all connections have been made properly.
<i>Humidifier does not operate (Screen turned On, <b>Status Display LED: Off</b>)</i>	The humidifier is not powered on.	Verify that the Power button has been pressed and held for 3 seconds for correct activation.
<i>Humidifier does not produce steam (No demand)</i>	No analog signal detected.	Verify the setting of the control input.
	Air flow is not detected by air pressure switch.	Check the fan operation.
	High limit humidistat is open.	Check the operation of the high limit humidistat.
	Interlock contact is open.	Check the interlock contact.
<i>No water inside the evaporation chamber or Humidifier does not stop draining</i>	Control wires are not properly secured to the terminal blocks.	Verify the connections of the wires to the control terminal blocks.
	Humidifier is being filled with water but has not yet reached or does not reach the high limit of the water level sensor.	<ul style="list-style-type: none"> <li>- Verify that the drain valve is open.</li> <li>- Check if the shutoff valve on the water supply line is open.</li> <li>- Verify the operation of the fill valve.</li> <li>- Check that the fill valve strainer and the external strainer are not blocked.</li> </ul>
<i>Humidifier does not drain</i>	Humidifier is not being filled with water.	<ul style="list-style-type: none"> <li>- Check that the fill valve strainer and the external strainer are not blocked.</li> </ul>
	Drain valve is clogged.	Check the drain valve.
<i>Humidifier is always on Foam cycle (<b>FoamSensor</b> setting displays <b>Foam</b>)</i>	During a drain or foaming cycle, the water level sensor has sensed that the water level has not decreased.	Verify that the drain pump, the fill and drain water pipe connections and the water level sensor chamber are not obstructed.
	Excessive foaming condition inside the evaporation chamber.	<ul style="list-style-type: none"> <li>- Verify the quality of the supply water.</li> <li>- Verify if chemical products were used to clean the evaporation chamber during maintenance. Rinse the chamber properly with water.</li> <li>- Check the setting of the drain cycle. Reduce the time between drain cycles.</li> </ul>
<i>Humidifier is operating and the Status Display LED is Red (<b>ServiceDue</b> setting displays <b>On</b>)</i>	The humidifier is due for servicing.	Service the humidifier (see Service section on page 59). Use <i>Request</i> setting in <i>Service</i> menu to reset counters (see page 45).
<i>Humidifier does not operate (Screen turned Off, <b>Status Display LED: Blue</b>)</i>	The following components can be the cause of this problem: water level sensor, PC board or LCD display.	Call factory for troubleshooting instructions.
<i>Humidifier is producing steam (Screen turned Off, <b>Status Display LED: Blue</b>)</i>	The display FFC cable is not connected properly.	Verify that the connections of the FFC cable are properly secured and are on the correct side.
	The LCD display is defective.	Replace the LCD display.



**neptronic®**

400 Lebeau blvd, Montreal, Qc, H4N 1R6, Canada

[www.neptronic.com](http://www.neptronic.com)

Toll free in North America: 1-800-361-2308

Tel.: (514) 333-1433

Fax: (514) 333-3163

Customer service fax: (514) 333-1091

Monday to Friday: 8:00am to 5:00pm (Eastern time)