

SKV EVAPORATIVE COOLING HUMIDIFIER



neptronic[®]
www.neptronic.com

SKV EVAPORATIVE COOLING HUMIDIFIER

In an evaporative humidifier, water is supplied to the top of the evaporative module and flows down the wet media (like a waterfall). Warm dry air passes through the wet media, evaporates water and thus raises the humidity level. The SKV also offers up to 12°C (21.5°F) of cooling as a result of the transfer of energy when the water evaporates.



Up to 12°C



± 1% RH

SKV Advantages

- Very low energy consumption (< 1kW)
- Hygienic operation
- Environmentally friendly
- Very low maintenance
- Free cooling up to 12°C (21.5°F)
- Custom modular design to fit any application
- Low pressure drop

Typical Applications

The SKV Evaporative Cooling humidifier is ideal for any application requiring cost effective and hygienic solutions for humidification needs with free cooling up to 12°C (21.5°F). With very low energy and water consumption, the SKV is the perfect complement to any green or LEED building. The SKV can be installed in applications such as:

■ Data Centers



■ Paint Shops



■ Amphitheaters



■ Greenhouses



■ Commercial Buildings



Typical Installation

Use the Neptronic Humidisoft web application to customize the evaporative module to your exact duct dimensions. This minimizes the need of blanking plates, thus ensuring a lower pressure drop.

The SKV is easy to install. Just connect the drain, water supply, power supply, and 6 low-voltage wires between the controller and the evaporative module. The controller's stainless steel IP56 rated enclosure allows for outdoor installations.

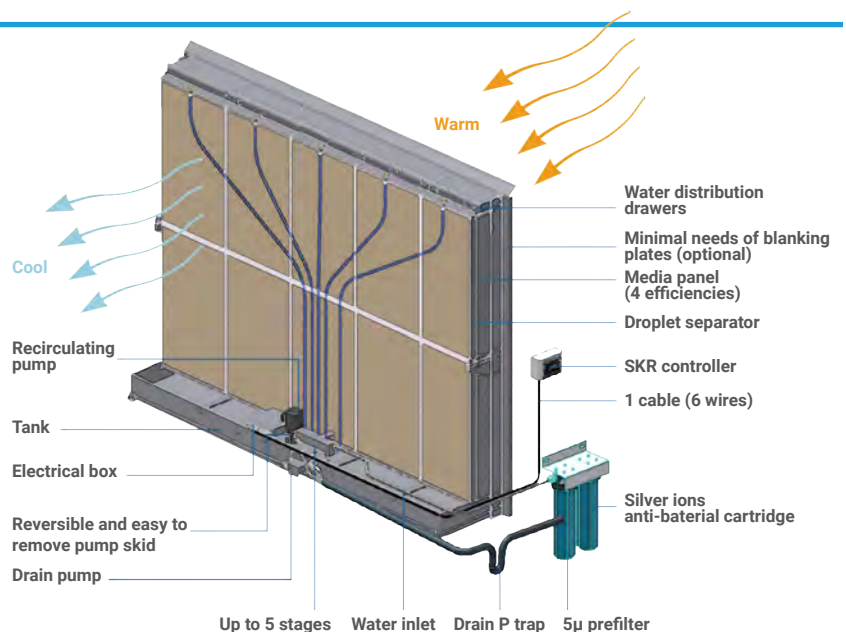

neptronic.com

System Overview

Inorganic Fibreglass Media

Hygienic, maintenance free, fire resistant and incombustible corrugated media, provides exceptional moisture absorption, for continuous humidification and evaporative cooling even at high air velocity.

Parametric Design

Use Neptronic Humidisoft web application to customize the evaporative module to your exact duct dimensions. This minimizes needs of blanking plate, thus ensuring a lower pressure drop.

Water Distribution Drawer

Easy to remove for cleaning and maintenance

Staging Valves

Offers up to 5 stages providing very flexible and accurate control

Circulation Pump

Robust pump functions with any water type (tap, RO or Di)

Drain Pump

Fast and reliable pump that can lift the drained water.

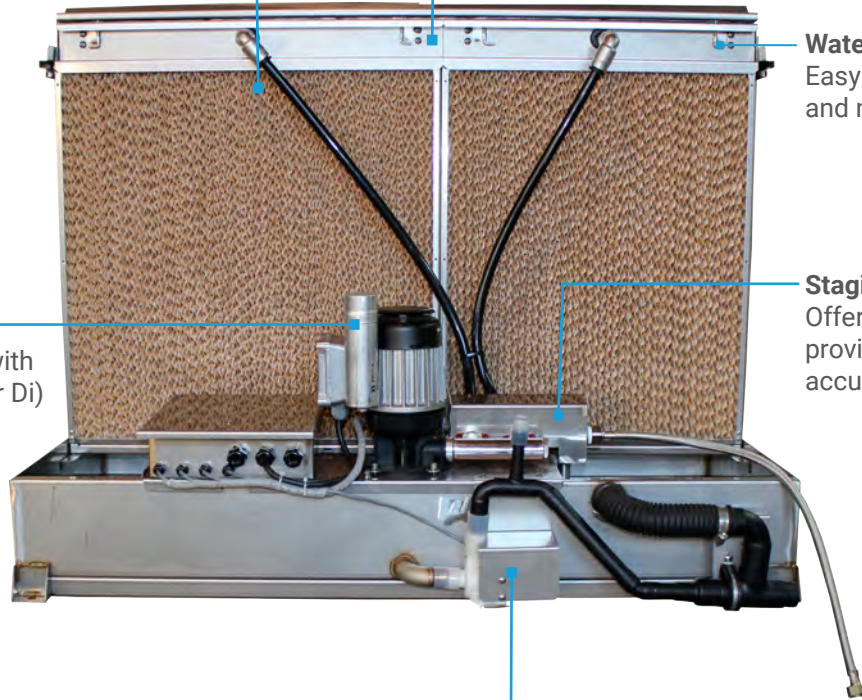

Silver Ion Cartridge

Water pretreated with 5µm pre-filter and anti-bacterial silver ions prevent microbial growth.

SKV Controller

The SKV controller is configured specifically for your SKV Evaporative Humidifier.

- Microprocessor based, field configurable controller
- Master/slave configuration for up to 4 evaporative modules
- On/Off or modulating control type
- Real-time clock with flexible scheduler
- Simple viewing and exporting of trending log and alarm log
- In-field firmware upgradeable via SD card
- Easy connection with only one 6-wire control cable
- Stainless steel IP56 rated (equivalent to NEMA type 4) enclosure for outdoor installations
- 8 buttons and menu driven 128 x 64 LCD



SKV Media Panels

The SKV Evaporative corrugated media is made of fibreglass material bounded with a special inorganic compound, which allows exceptional moisture absorption, ensuring continuous humidification and evaporative cooling even at a high air velocity. The inorganic compound makes it hygienic, fire resistant and incombustible.

- Inorganic and inflammable material
- Safe & hygienic
- Low pressure drop
- Trouble free maintenance
- No water treatment required
- No risk of over saturation
- Available in 4 efficiencies: 65%, 75%, 85% and 95%
- Media frame made of stainless steel
- Media easily removable from stainless steel frame

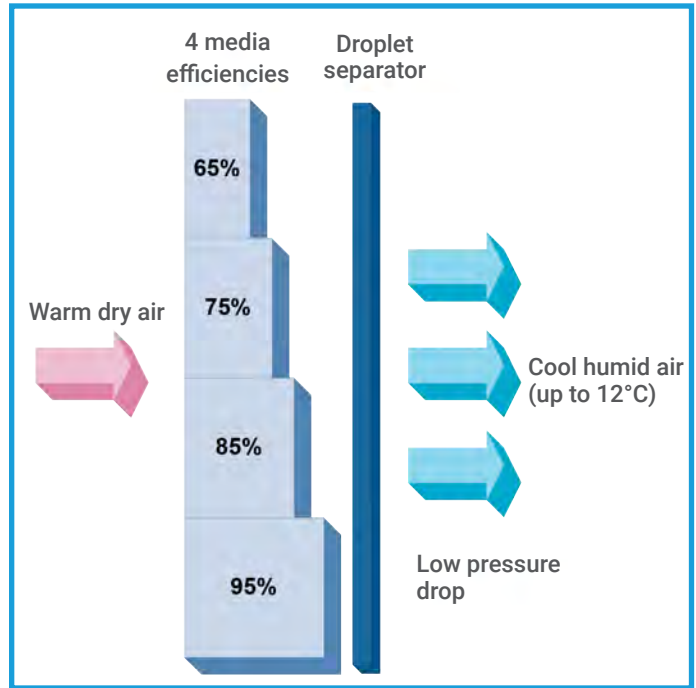

Water Quality

Hygienic operation with any type of supplied water quality (tap, RO or Di)

- Self-cleaning, odor free media
- Water treated with 5µm pre-filter
- Anti-bacterial silver ion dosing cartridges prevent microbial growth
- UV sterilizer on water line (optional)

How Silver Ions Work

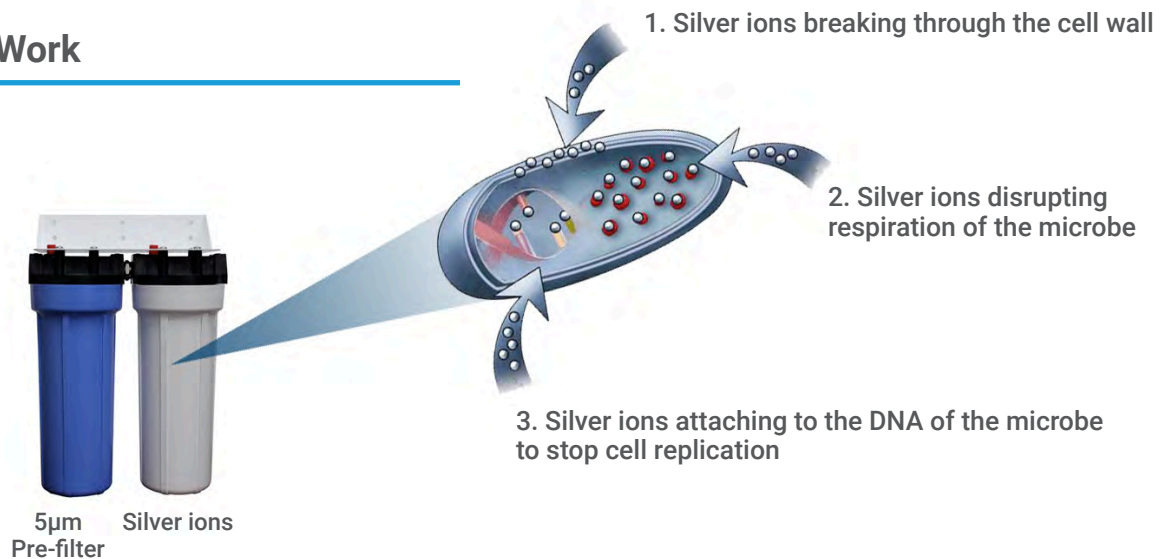

Easy Maintenance

The SKV has been designed for easy access to components of the evaporative module for maintenance. Five easy steps:

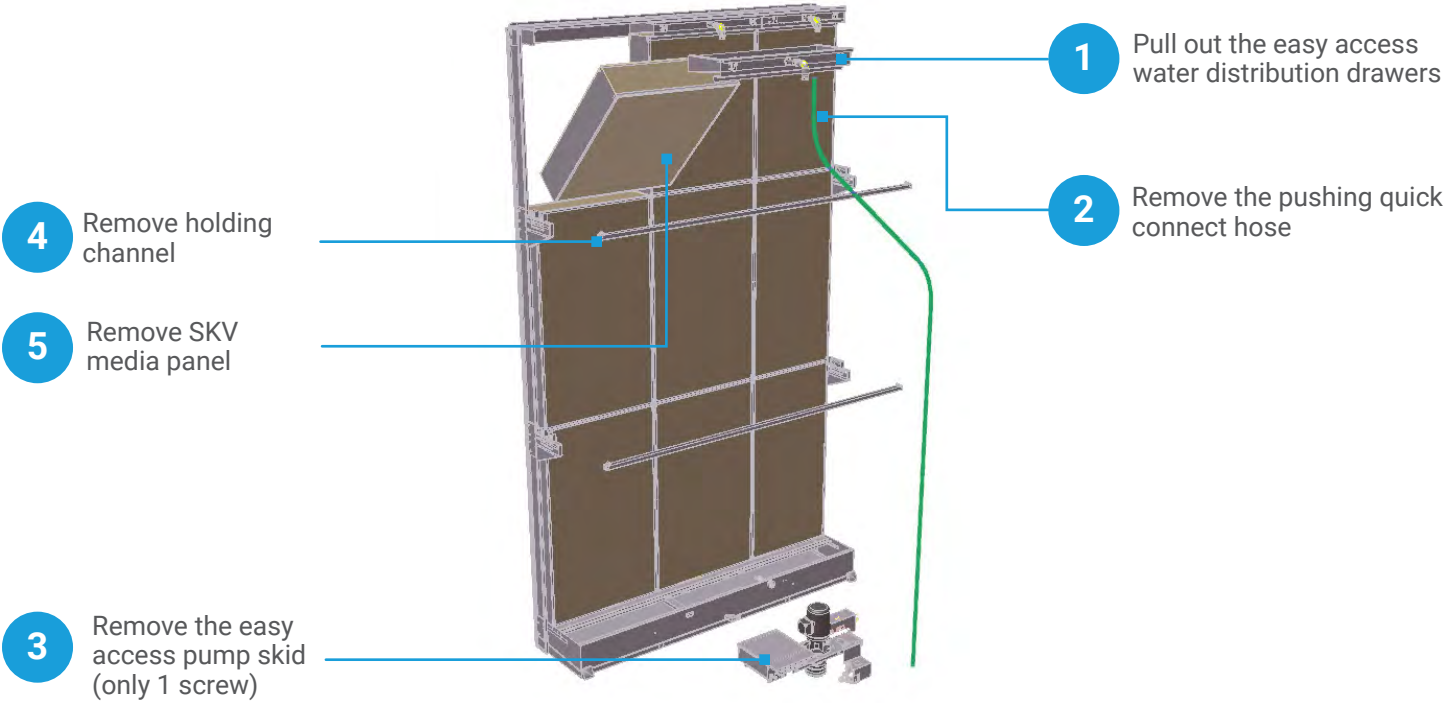

Nomenclature

SKV R 95 C 1 D C

- Type**
R: Recirculation
D: Direct Feed
O: OEM
- Media Efficiency**
65: 65% efficiency
75: 75% efficiency
85: 85% efficiency
95: 95% efficiency
- Controller**
C: Controller (standard)
B: BACnet controller
-: None
- No. of Stages**
1: 1 Stage
2: 2 Stages
3: 3 Stages
4: 4 Stages
5: 5 Stages
- Droplet**
D: Droplet separator included
- Voltage**
A: 120Vac
C: 230Vac

Standards for media

- European:**
- EN 13501-1, Fire classification of construction products and building elements-Part1: Classification using data from reaction to fire test
 - EN 1182, Non combustibility test method of building materials
 - EN 13823, Reaction to fire test for building products. Fire class **A2**, Smoke production class: **s2**, flaming particles class: **d0**
 - ISO 846, Evaluation of the action of microorganisms' microbiology testing lab
 - ILH Berlin tested and found to fulfill the requirements from VDI6022 Part I, suitable for use in HVAC-systems.
- North American:**
- UL 900, Air Filter Units
 - ETL tested, Class I (no flame or spark, Less than 2.5sq.in of smoke)

Specify your SKV online

Humidifier System Design and Specification Web Application

Ready to specify your Humidifier? Nepronic has developed a web application that saves you time when sizing and specifying Nepronic commercial, industrial or residential humidifiers.



Features

- Automatic humidification load calculation
- Customize evaporative module to exact duct dimensions
- Web based
- Selection specific report generator
- Only options related to your selections appear
- Manage users, clients, job sites and humidifier specs
- History log

Project	Humidifier	Dispersion	Options	Reports	Pricing
Type					
<input type="radio"/> Isothermal (Hot Steam) <input checked="" type="radio"/> Adiabatic (cold mist)					
Category					
<input type="radio"/> SKA Atomizing <input checked="" type="radio"/> SKV Evaporative					
Indoor Conditions		Application		Distribution	
Temperature	22.0 °C	<input checked="" type="radio"/> Humidity <input type="radio"/> Cooling		<input checked="" type="radio"/> In Duct <input type="radio"/> In Space	
Relative Humidity	40 %				
Ventilation System					
Total Air Flow	60000 m ³ /hr	Minimum OFF Temperature		8 °C	
Outside Air	100 %	Pre-Heat(Δ Temp)			
Frost Coil (Δ Temp)	0.0 °C	2.9 °C			
OFF (supply) Temp	22.0 °C				
Humidifier(s)					
<input type="checkbox"/> Enter Load Manually		Calculated Load	137.41 kg/hr	Total Capacity	137.41 kg/hr

Easy to Use

Go to nepronic.com, select Humidisoft and log in. Enter design requirements and Humidisoft automatically calculates the humidification load and adjusts available options based on your selections. When done, print a complete schedule, CSI and/or submittal report at the click of a button.

Project	Humidifier	Dispersion	Options	Reports	Pricing
Duct Dimensions		System Pressure			
Width	3500 mm	<input checked="" type="radio"/> Negative <input type="radio"/> Positive			
Height	3000 mm				
Mixed Conditions		ON Conditions		OFF Conditions	
Temperature	24 °C	Temperature	26.9 °C	Temperature	22 °C
Relative Humidity	28 %	Relative Humidity	21 %	Relative Humidity	40 %
Humidification					
Humidification Efficiency	37 %	Face Velocity			
Face Velocity	2.5 m/s				
Dispersion					
Model	Dimension (width x height)	Pressure Drop			
SKV SKV Evaporative	3000mm x 2750mm	30Pa Total: 30Pa			

Humidifier Product Line



Electric



SKE4

- Capacities from 6 - 300 lb/hr
- Remove chamber easily, without tools
- Outdoor unit available

Gas Fired



SKG4

- Capacities from 110 - 810 lb/hr
- Modular design
- Outdoor unit available

Steam to Steam



SKS4

- Capacities from 33 - 1250 lb/hr
- Scale management system for easy maintenance
- Insulated external panels

Residential



SKR

- Capacities from 4.5 - 12 lb/hr
- Permanent cleanable chamber
- Reliable siphon drain

High Pressure Atomizer



SKH

- Capacities up to 4638 lb/hr
- Up to 10 zones
- Installation in-duct or in-space

Evaporative

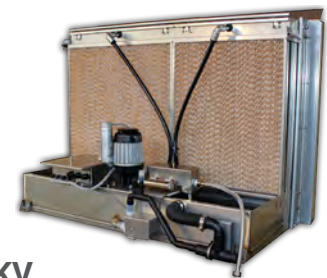

SKV

- Free cooling up to 22°F (12°C)
- Custom design to fit your application
- Hygienic operation with silver ion dosing system

Direct Steam



SKD

- Capacities from 5 - 1650lb/hr
- Jacketed or Multi-Steam™ SD/HD
- Unique electronic steam controller
- Optional pressurized condensate return (PCR) system

Steam Distribution



Distribution

- Multi-Steam™ SD/HD distribution
- S.A.M. & S.A.M.E2 wands
- SDU (Space distribution unit)

Humidity Controls



Controls

- Humidity controls/sensors
- Safety controls
- BACnet compatible

MANUFACTURER OF ■

- HVAC CONTROLS
- ELECTRIC ACTUATORS
- ACTUATED VALVES
- HUMIDIFIERS
- ELECTRIC HEATERS

■
www.neptronic.com