



neptronic®

Steam Humidifier

SK300 Series

Installation Instructions and User Manual



Read and save these instructions

Foreword

Neptronic Company Overview

Founded in 1976, we're a private corporation that designs, manufactures and distributes products for the HVAC industry. Our product line includes intelligent controllers, electronic actuators, actuated valves, humidifiers and electric heaters.

Our products are designed and manufactured by over 250 dedicated employees in our 7,500 m² (80,000 ft²) state-of-the-art facility located in Montreal, Canada. Using a vertical integration model, our entire manufacturing chain is under one roof from software and hardware development, to SMT circuit board assembly, to sheet metal fabrication, to product testing ensuring that our products are engineered to last.

We currently hold several national and international patents and with our continued commitment to research and development, we provide innovative products and technologies for the ever-evolving challenges of the HVAC industry. Exporting over 70% of our sales, we have an exclusive distribution network around the globe that provides comprehensive solutions to our worldwide customers.

About the Manual

These installation and operation instructions have been developed to facilitate the installation of the Steam Humidifier.

- The strict application of these instructions will ensure the conformity of your installation and operation as per the manufacturer's recommendations.
- The application of these instructions is one of the conditions for the application of the warranty.
- The application of these instructions does not ensure, at any time conformity to procedures, regulation or local codes, regarding electric installation and connection to local water supply.

This product has been declared to conform to the applicable Canadian and American safety standards and directives and bear the CSA (c) & (us) mark. The Certificate of Conformity, CSA is available, upon request with the manufacturer.

2018[®]: All rights reserved. This document cannot be reproduced totally or partially by any means whether, electronic, mechanical, photocopy, recording or other, without prior written authorization of Neptronic.

Electricity



All work concerned with electrical installation **MUST** only be performed by skilled and qualified technical personnel such as an electrician or a technician with appropriate training). The customer is always responsible for ensuring the suitability of the technical personnel.

Please observe the local regulations concerning the provision of electrical installations.

Correct Use

Neptronic systems and its products are designed only for humidification use. Any other application is not considered appropriate for the intended purpose. The manufacturer cannot be made liable for any damage resulting from incorrect use.

General Warranty

This product is subject to the terms and conditions described at <http://www.neptronic.com/Sales-Conditions.aspx>.

Handling and Lifting



Lifting or handling **MUST** be carried out by trained and qualified personnel. Ensure that the lifting operation has been properly planned, assessed for risk and that the equipment has been checked by a competent Health & Safety representative, and effective control measures are in place.

It is the customer's responsibility to ensure that the operators are trained in handling heavy goods and to enforce the relevant lifting regulations.

The Steam Humidifier **MUST** always be handled and lifted with care and should remain in its original packaging for as long as possible prior to installation.

The Steam Humidifier package may be carried using a forklift from the underside. Caution should be exercised to ensure balanced load before lifting.

Unpacking

The Steam Humidifier is shipped inside carton boxes or in a wooden crate. Remove packing and skids prior to commissioning.

Contents

Handling and Lifting	ii
Overview	4
List of Accessories Supplied	4
Visual Overview	4
Available Options	5
Description of Components	5
Humidifier with Space Distribution Unit	6
Dimensions and Weight	6
Weather Proof Enclosure	7
Weather Proof Enclosure - Dimensions and Weight	7
Output and Power Consumption - Humidifier	8
Mechanical Installation	9
General Recommendations	9
Location	9
Positioning	10
Wall Mounting	11
Positioning and Mounting – Weather Proof Enclosure Unit	12
General Recommendations	12
Steam Dispersion System	13
Steam Dispersion System Selection	13
Positioning S.A.M and S.A.M.E2	14
Placement of Steam Pipe in Horizontal Duct	15
Placement of Steam Pipe in Vertical Duct	16
Steam Output Connections	17
Installation	17

General Recommendations	17
Position of Steam Output	19
Small Cabinet	19
Medium Cabinet	19
Large Cabinet	19
Installation - Humidifier with SDU	20
Remote Installation of SDU	20
Maintenance of the SDU	21
Plumbing Connections	22
Water Supply	22
Water Connections	23
Drain Connections	23
Weather Proof Enclosure Plumbing Connection	24
Water Drain Valve	24
Power Supply Connections	25
Low Voltage Control Connections	26
ON/OFF Humidifier	26
Modulating Humidifier	26
Common Alarm Connections	30
Controls Placement (Steam Dispersed into a Duct or AHU)	30
Display	31
Front Panel	31
Modes – Description	32
OFF Mode	32
Scroll Mode	32
List of Alarms	33
Programming Mode	33
Control P.C. Board	35
Main P.C. Board	35
Modulating P.C. Board	36
Start-up Procedure	36
Service	37
Clean the Evaporation Chamber	37
Exploded View and Bill of Material	42
Exploded View	42
Bill of Material	43
Troubleshooting	45

Overview

List of Accessories Supplied

The following accessories are supplied with the SK300 Steam Humidifier:

- 2 sets of keys.
- 2 adjustable collars for the connection of the steam hose for each steam output.
- 1 female compression fitting $\frac{3}{4}$ (DN20) hydraulic for the drain output of the evaporation chamber.
- 1 female compression fitting $\frac{1}{2}$ (DN15) hydraulic for the drain output of the drip pan.
- 1 female fitting and a braided hose for the water supply connection.
- 1 Installation Instructions and User Manual.

Visual Overview

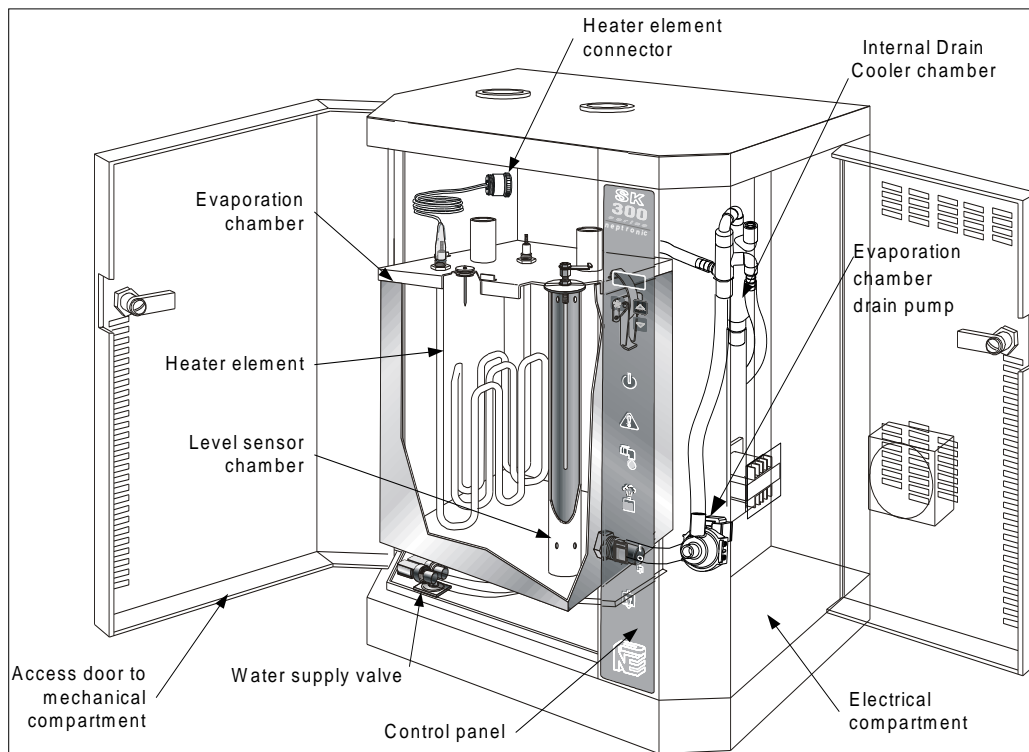

Illustration 1 - Overview of the Humidifier

Available Options

The following options are available when purchasing an SK300 humidifier:

Model	Description
Suffix M (SK320M)	Modulating control humidifier
SF DI-APPLICATION	Humidifier for a system supplied with Deionised water or Reverse Osmosis water, dissolved solids more than 5 ppm
SF ULTRAPURE-DI	Humidifier for a system supplied with Deionised water or Reverse Osmosis water, dissolved solids more than 0.0625 ppm
SDU-REM	Space Distribution Unit mounted on humidifier (SDU) or remote installation
Suffix B (SK320M-600-3B)	Network Communication System - BACnet
SK320M-600-3P	Stainless steel humidifier cabinet
SF SK300 FANRELAY	Dry contact to activate an external fan relay on a call for humidity

Description of Components

- *Evaporation Chamber.* Assembly includes a metal cylinder and a cover equipped with one or several heater elements. It is the most important part of the humidifier, which produces the steam.
- *Space Distribution Unit (SDU).* Integrated steam distribution unit, optional on certain humidifiers.
- *Multi-Steam System.* Custom made system for steam distribution. This system is designed to allow very short absorption distances (less than 3 feet or 900mm) applications.
- *Steam Absorption Manifold (S.A.M.).* Steam manifold adapted to air duct size allows steam absorption in relatively short distance (less than 5 feet or 1500mm) applications.
- *Steam Absorption Manifold with 2 Eyelets (S.A.M.E2).* Steam manifold with two eyelets adapted to applications with restricted air duct dimensions that allow steam absorption in relatively short distance (less than 5 feet or 1500mm) applications.



Humidifier with Space Distribution Unit

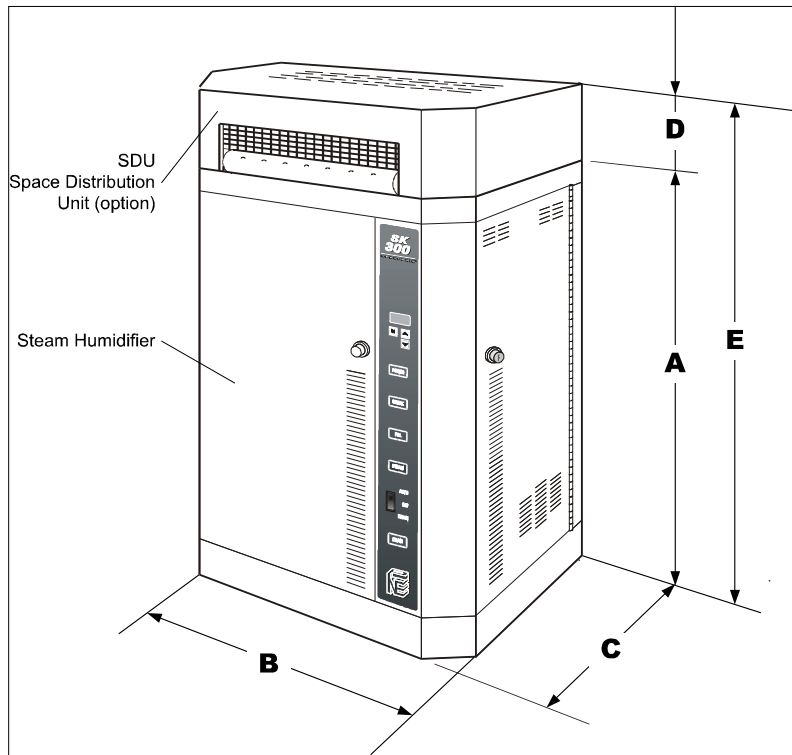

Illustration 2 - Steam Humidifier with Space Distribution Unit

Dimensions and Weight

Table 1 - Dimensions and Weight of SDU

Model	Dimensions of the Cabinet inch (mm)					Weight lb (kg)		SDU lb (kg)
	A	B	C	D	E	Empty	Full	
SK302	23 ½ (597)	18 ½ (470)	11 ½ (292)	5 ⅝ (140)	29 ⅛ (737)	44 (20)	57 (26)	SDU-1 20 (9)
SK304								
SK306								
SK310	28 ½ (724)	21 (533)	12 ½ (318)	6 ⅝ (165)	35 ⅛ (890)	66 (30)	115 (52)	SDU-2 25 (11)
SK314								
SK316								
SK320	28 ½ (724)	21 (533)	12 ½ (318)	12 ⅞ (324)	41 ⅜ (1048)	66 (30)	115 (52)	SDU-3 45 (20)
SK330								
SK320 L								
SK340	31 ¼ (794)	32 (813)	12 ½ (318)	-	-	110 (50)	205 (93)	-
SK350								
SK360								



Weather Proof Enclosure

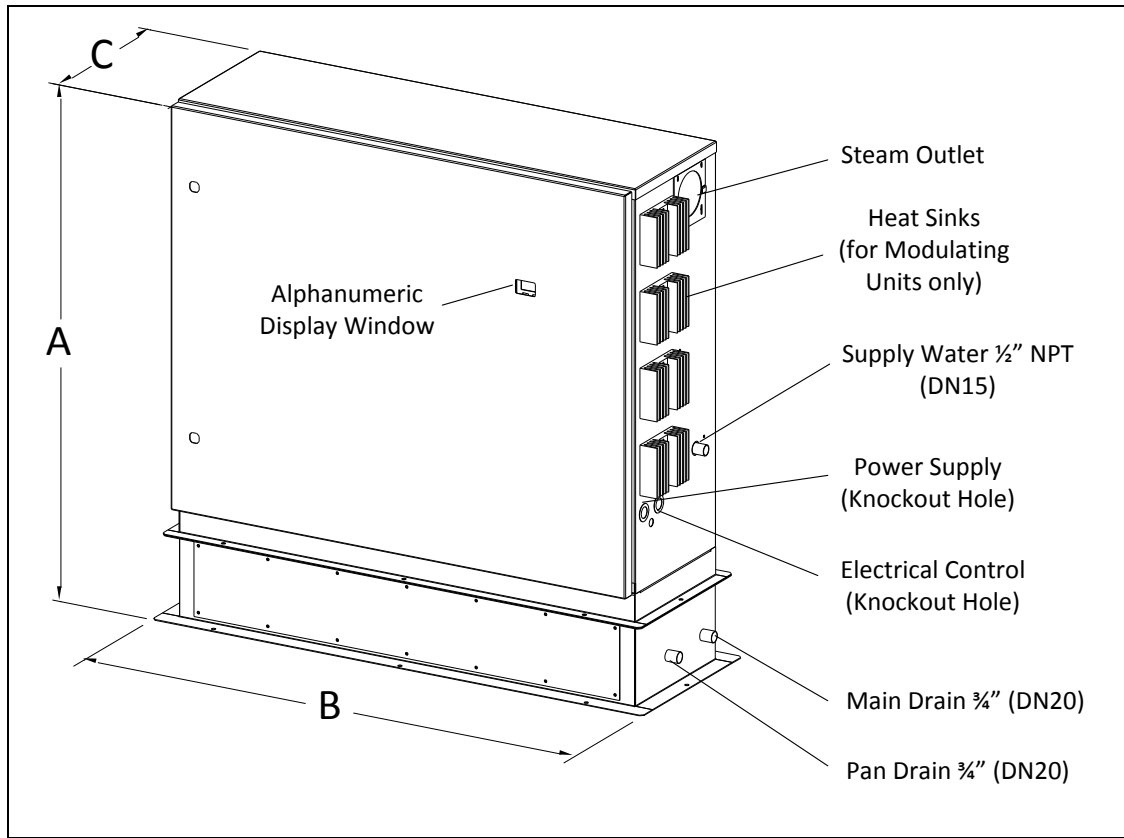

Illustration 3 - Weather Proof Enclosure

Weather Proof Enclosure - Dimensions and Weight

Table 2 - Weather Proof Enclosure: Dimensions and Weight

Model	Dimensions of the Cabinet inch (mm)			Weight lb (kg)	
	A	B	C	Empty	Full
SK302 SK304 SK306	35.1 (892)	26.9 (682)	11.3 (287)	66 (30)	79 (36)
SK310 SK314 SK316 SK320 SK330	40.7 (1034)	30.9 (784)	13.3 (338)	95 (43)	144 (65)
SK320 L SK340 SK350 SK360	40.7 (1034)	41.9 (1063)	13.3 (338)	165 (75)	260 (118)



Output and Power Consumption - Humidifier

Table 3 - Output and Power Consumption

Model	Steam		Consumption								Steam Output	
	Capacity lb/hr (kg/hr)	Power (KW)	Amperage (A)								Qty	Diameter inch (mm)
			120/1	240/1	208/1	208/3	480/1	480/3	600/1	600/3		
SK302	6 (2.7)	2	17	8.5	10	-	4.5	-	3.5	-	1	1 3/8 (35)
SK304	12 (5.5)	4	-	17	19	11.5	8.5	5	7	4	1	1 3/8 (35)
SK306	18 (8)	6	-	26	30	16.5	13	7.2	10.5	6	1	1 3/8 (35)
SK310	30 (14)	10	-	-	-	28	-	12	-	10	1	1 3/8 (35)
SK314	40 (19)	13.5	-	-	-	38	-	16.5	-	13.5	1	1 3/8 (35)
SK316	48 (21.8)	16	-	-	-	45	-	-	-	16	2	1 3/8 (35)
SK320	60 (28)	20	-	-	-	-	-	25	-	20	2	1 3/8 (35)
SK330	90 (41)	30	-	-	-	*	-	36	-	30	2	1 3/8 (35)
SK320 L	60 (28)	20	-	-	-	56	-	-	-	-	2	2 1/8 (54)
SK340	120 (56)	40	-	-	-	*	-	50	-	40	2	2 1/8 (54)
SK350	150 (68)	50	-	-	-	-	-	60	-	50	3	2 1/8 (54)
SK360	180 (82)	60	-	-	-	-	-	72	-	60	3	2 1/8 (54)

* Available, consult factory.



Note: Program maximum steam output using the Lock On function in Program Mode on Modulating Humidifier.



WARNING: For Modulating Humidifier, maintain the maximum power of the electrical installations according to the information in Table 3 - Output and Power Consumption.

Do not consider a possible reduction of steam output due to modulation.

Mechanical Installation

General Recommendations



WARNING: Risk of electric shock. Disconnect the appliance from electric supply before commencing installation.



Note: Mechanical installation should conform to local codes and regulations.

Location



WARNING: The SK300 series humidifiers are designed for indoor installation only.

For outdoor installation, the SK300 must be installed using a Neptronic weather-proof enclosure (see

Positioning and Mounting – Weather Proof Enclosure Unit on page 12).

Failure to follow these guidelines will void the warranty.

Consider the following points before deciding the location for the SK300 Steam Humidifier:

- Plan a location that is easy to access and permits an easy inspection and servicing of the humidifier.
- Do not install the humidifier where the failure of the appliance could cause damage to the building structure or other expensive equipment.
- The location should be well ventilated, and the ambient temperature should not exceed 85°F (30°C).
- Consider the total steam line length between the humidifier and the steam distributor based on the steam line material type:
 - For flexible steam hose, the total steam line should not exceed 16 feet (5 meters). For longer distances, use insulated hard piping.
 - For insulated hard piping, the total steam line is determined by the humidifier capacity: one equivalent foot for each lb/h capacity of the humidifier (0.67m for each kg/h), with a maximum of 50 feet (15m). For longer steam line runs, consult factory.

Positioning

- The front panel and the right side (electrical compartment) should be accessible in order to permit servicing.
- Leave a clearance of at least 48" (1.25m) to the front panel and 24" (0.6m) to the right side.
- Mount the humidifier at a minimum height of 39" (1m) to 48" (1.2m) above floor level.
- Leave a clearance of at least 10" (0.25m) under the humidifier for installation of water supply, drain piping, and electrical connections.

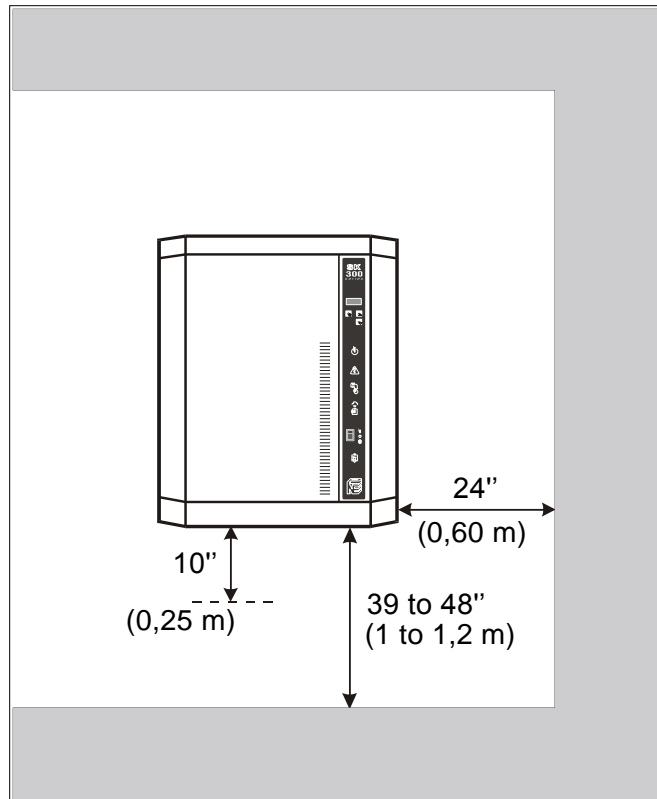

Illustration 4 - Positioning the Humidifier

Wall Mounting



Caution: Risk of malfunction. The humidifier must be placed at an equal level.

Caution: Risk of overheating. Do not block the ventilation openings located on the top, front, sides, and rear of the cabinet.

Check the strength of the chosen support or wall (bricks, concrete, stud partition wall) on which the humidifier will be mounted. See the Dimensions and Weight section to know the weight of the unit.

- Use the keyholes located on the back panel of the humidifier.
- Before proceeding to perform the wall mounting, take off the Evaporation Chamber sub-assembly (see Service section).
- Drill holes for the upper anchors (holes with eyelet) into the support or wall as per dimensions specified in Table 4 - Dimensions for Drilling Holes.
- The holes' dimensions (diameter and depth) should be in accordance with the recommendations of the chosen anchors.

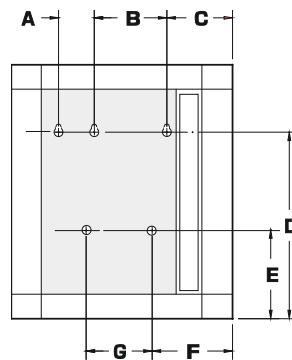

Table 4 - Dimensions for Drilling Holes

Model	Dimensions in inches (mm)						
	A	B	C	D	E	F	G
SK302 SK304 SK306	-	8 (202)	5 3/16 (165)	19 3/4 (516)	-	-	-
SK310 SK314 SK316 SK320 SK330	-	10 (254)	8 (203)	24 5/8 (625)	11 (276)	8 (203)	10 (254)
SK320 L SK340 SK350 SK360	4 (102)	12 (305)	10 1/2 (265)	27 1/2 (698)	11 (276)	22 43/64 (576)	-

- Install bolt anchors, if required.
- Screw-on the 2 or 3 upper screws (holes with eyelet) of a minimum diameter of #10 (6mm) (screws are not supplied).
- Leave a clearance between head screws and the wall, to permit the mounting of the humidifier.
- Use the keyholes located on the back panel of the humidifier.
- Hang the humidifier on 2 or 3 screws. It is preferable to keep the front door open during this operation. Based on the size and weight of the humidifier, you may need the help of another person.
- When the humidifier is positioned on the upper screws, tighten the screws to secure the humidifier.
- If applicable, install and secure lower screws.



Positioning and Mounting – Weather Proof Enclosure Unit

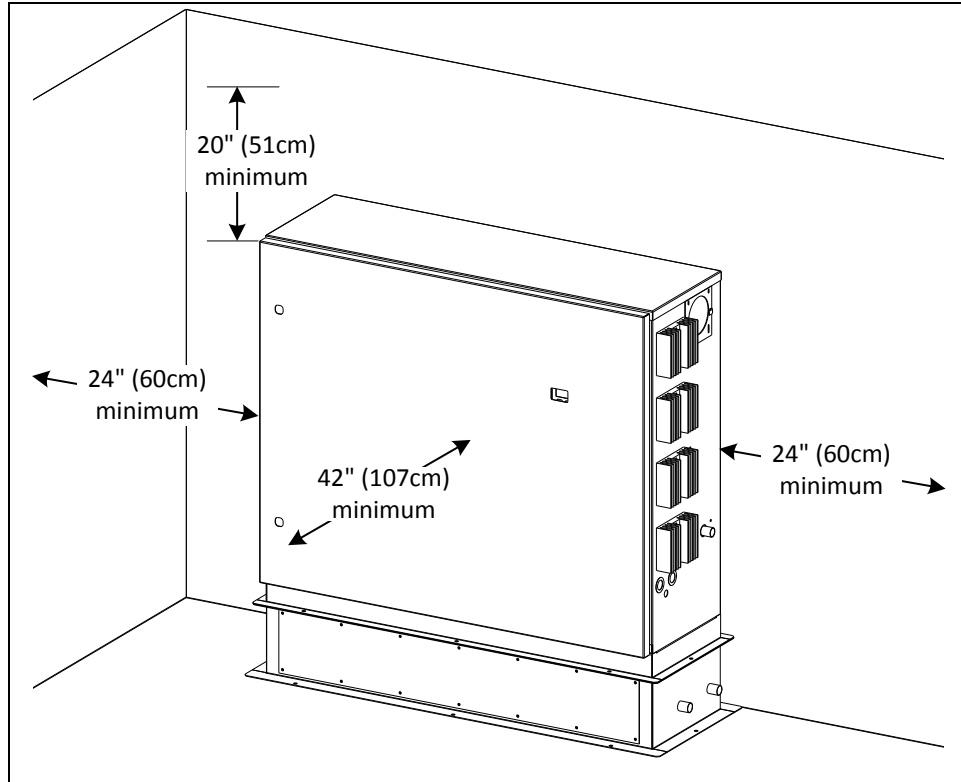

Illustration 5 - Weather Proof Enclosure Unit

General Recommendations

- Plan a location that is easy to access and permits an easy inspection and servicing of the humidifier.
- Do not install the humidifier where failure of the appliance could cause damage to the building structure or to other expensive equipment.
- Maintain the following minimum clearances while installing to enable access for inspection and servicing.

Side	Minimum Clearance
Top	20" (51 cm)
Both sides	24" (60 cm)
Front	42" (107 cm)

- The humidifier is designed to be installed directly on the floor/roof or a curb.
- Provide a level, solid foundation for the humidifier.
- Ensure that the floor/roof beneath the humidifier is waterproof to withstand any water spillage during servicing or if a problem occurs.
- Attach the SK enclosure securely and safely.

Steam Dispersion System

Steam Dispersion System Selection

To prevent the accumulation of condensation in air ducts, Neptronic has designed four basic configurations of steam distribution systems to provide you with the most economical solution for any particular application.

Steam Absorption Manifold (S.A.M) Horizontal Duct

The S.A.M system is suitable for installations where absorption distances are short, less than 5 feet (1500mm), and/or low duct temperatures are in effect.

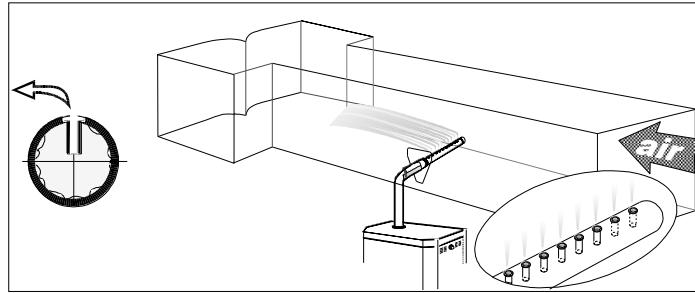

Illustration 6 - Steam Absorption Manifold (S.A.M) Horizontal Duct

Steam Absorption Manifold (S.A.M.E2) Horizontal Duct

The S.A.M.E2 system is suitable for installations where absorption distances are short, less than 5 feet (1500mm) and/or low duct temperatures are in effect. SAME2 are used in applications with restricted duct dimensions.

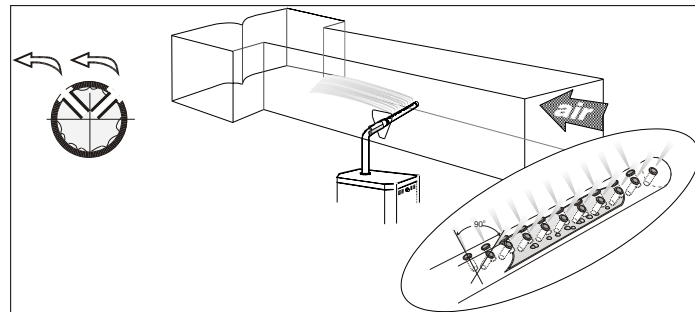

Illustration 7 - Steam Absorption Manifold (S.A.M.E2) Horizontal Duct

Steam Absorption Manifold (S.A.M. or S.A.M.E2) Vertical Duct

S.A.M or S.A.M.E2 systems for vertical ducts are used where the absorption distances are normal and the requirement is for an economical and efficient solution.

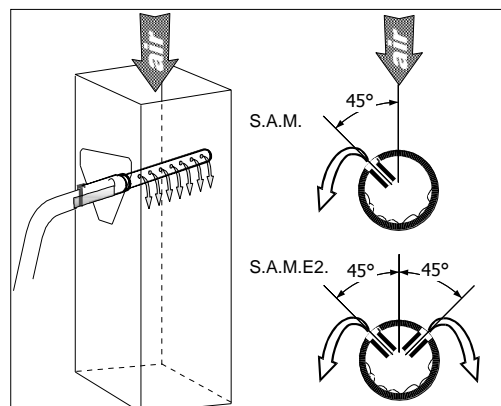

Illustration 8 - Steam Absorption Manifold (S.A.M. or S.A.M.E2) Vertical Duct

Multi-Steam System

The Multi-Steam system should be installed in critical locations in air handling systems, particularly where absorption distances are very short, less than 3 feet (900mm), or low air duct temperatures are in effect. The Multi-Steam is custom made to the dimensions of duct or AHU.

Instructions to install Multi-Steam system are described in a specific installation instructions manual enclosed with the Multi-Steam system.

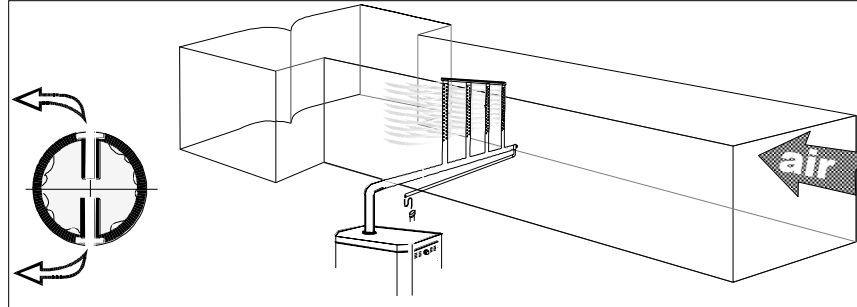

Illustration 9 - Multi Steam System

Positioning S.A.M and S.A.M.E2

Duct Mounting

The steam manifold should be mounted and secured through the side of the air handling unit or duct. Provision should be made for safe accessibility, ideally with an observation light and window. Ensure that the construction of the duct wall is suitable enough to support the steam pipe for the duration of the installation life.

Dimension of hole size in the duct must be as follows:

Steam Manifold Ø	Hole Size ØA
1 3/8" (35mm)	2" (51mm)
2 1/8" (54mm)	3" (78mm)

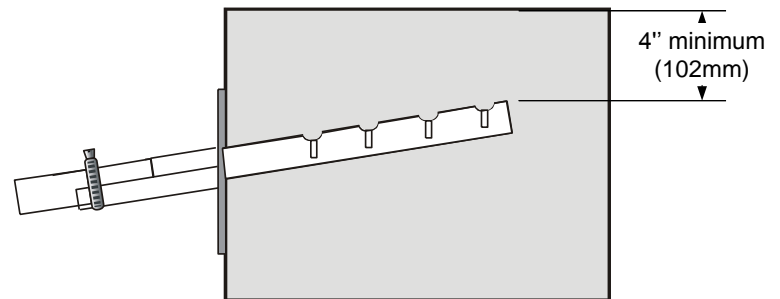
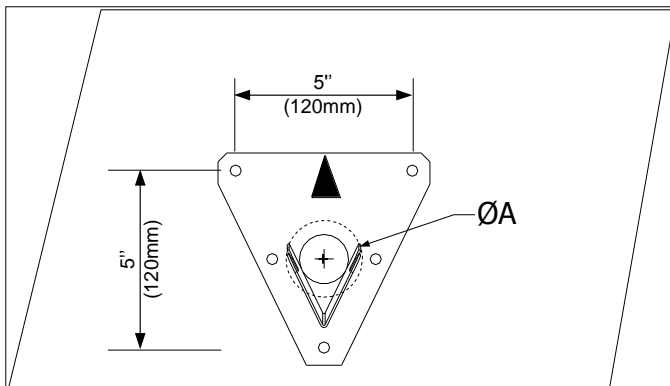

Illustration 10 - Duct Hole Dimensions and Minimum Distance



WARNING: Risk of condensing. Ensure that the minimum distance at the end of the manifold is at least 4" (102mm) from the top of the duct.

Recommendation for S.A.M Distribution Pipes

Table 5 - Recommendation for S.A.M Distribution Pipes

Model	Max Capacity		Outlet		Distribution Pipes		Max Static Pressure	
	lb/hr	kg/hr	Qty	Diameter	Min Length	Max Length	in. of water	(Pa)
				in (mm)	in (mm)	in (mm)		
SK302	6	2.7	1	1 3/8 (35)	12 (300)	24 (600)	5	1245
SK304	12	5.5						
SK306	18	8						
SK310	30	14						
SK314	40	19						
SK316	48	22	2	2 1/8 (54)	32 (800)	64 (1600)	5	1245
SK320	60	28						
SK330	90	41						
SK320 L	60	28						
SK340	120	56						
SK350	150	68	3	2 1/8 (54)	32 (800)	64 (1600)	5	1245
SK360	180	82						

For higher static pressure, contact the manufacturer.

Placement of Steam Pipe in Horizontal Duct

1 3/8" (35mm) Diameter Pipe

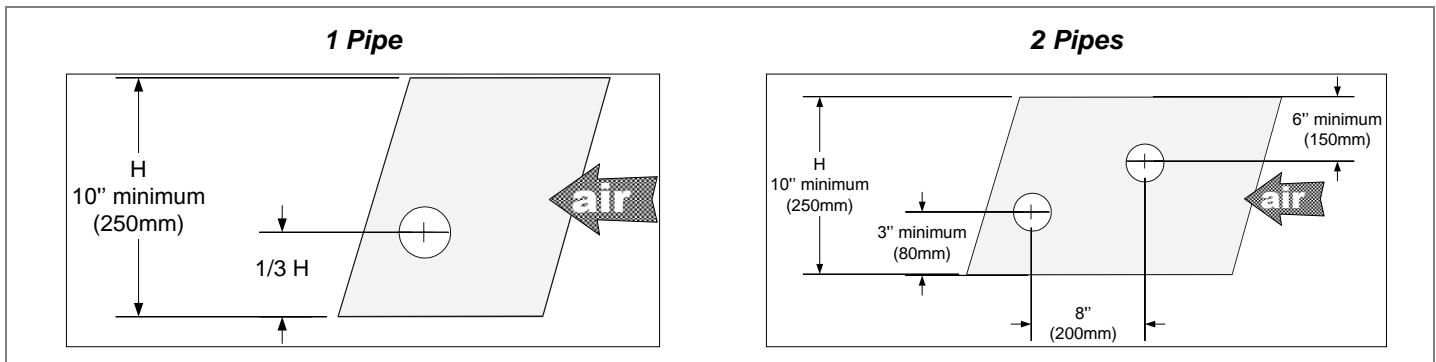

Illustration 11 - 1 3/8" (35mm) Diameter Pipe Placement: Horizontal Duct

2 1/8" (54mm) Diameter Pipe

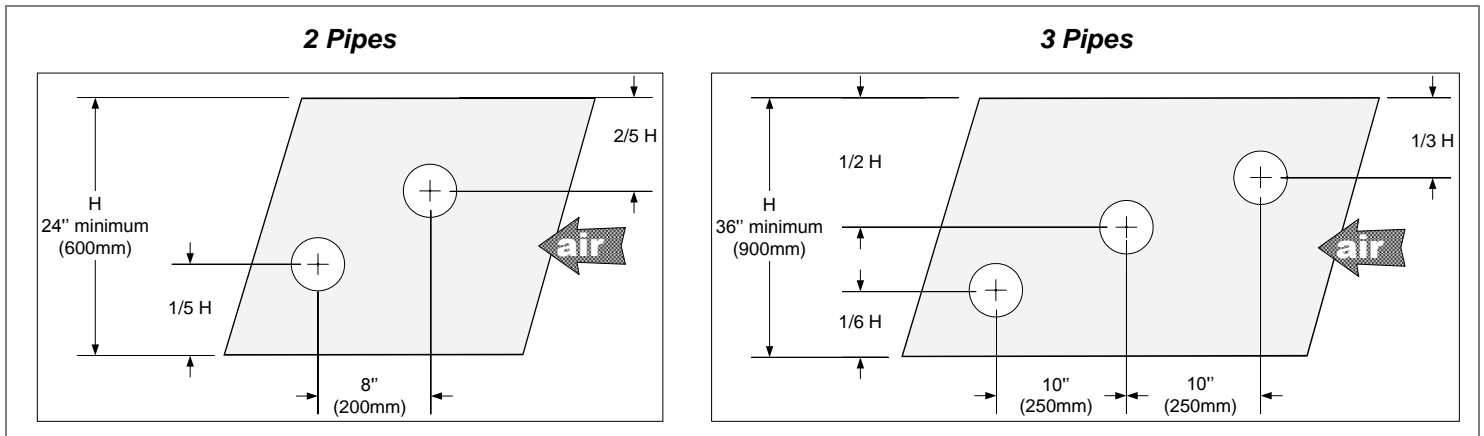

Illustration 12 - 2 1/8" (54mm) Diameter Pipe Placement: Horizontal Duct



Note: 2 1/8" (54mm) steam pipe must be supported on the end by appropriate duct hanger or strap (supplied by others).

Placement of Steam Pipe in Vertical Duct

Eyelet Orientation

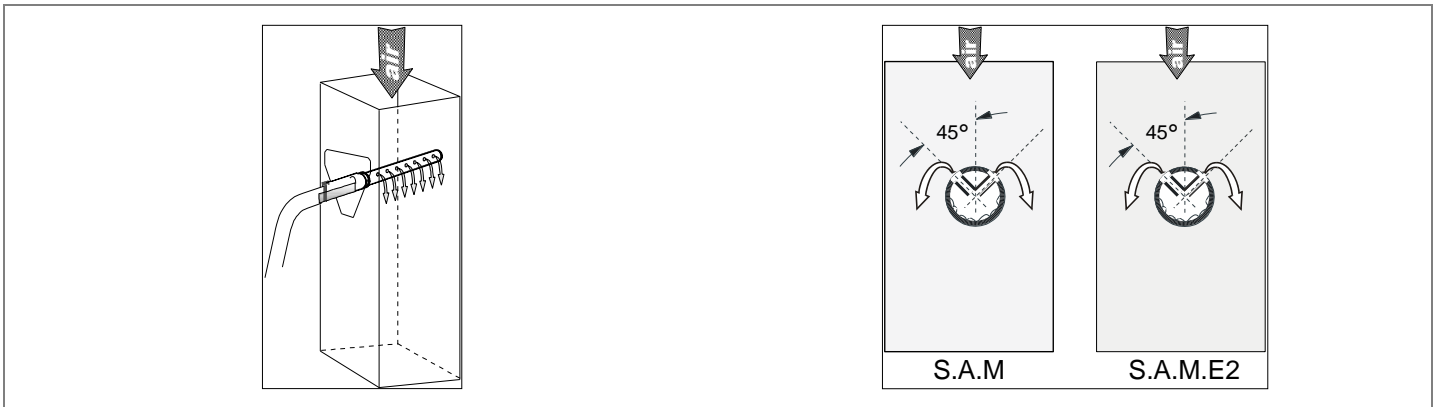

Illustration 13 - Eyelet Orientation

1 3/8" (35mm) Diameter Pipe

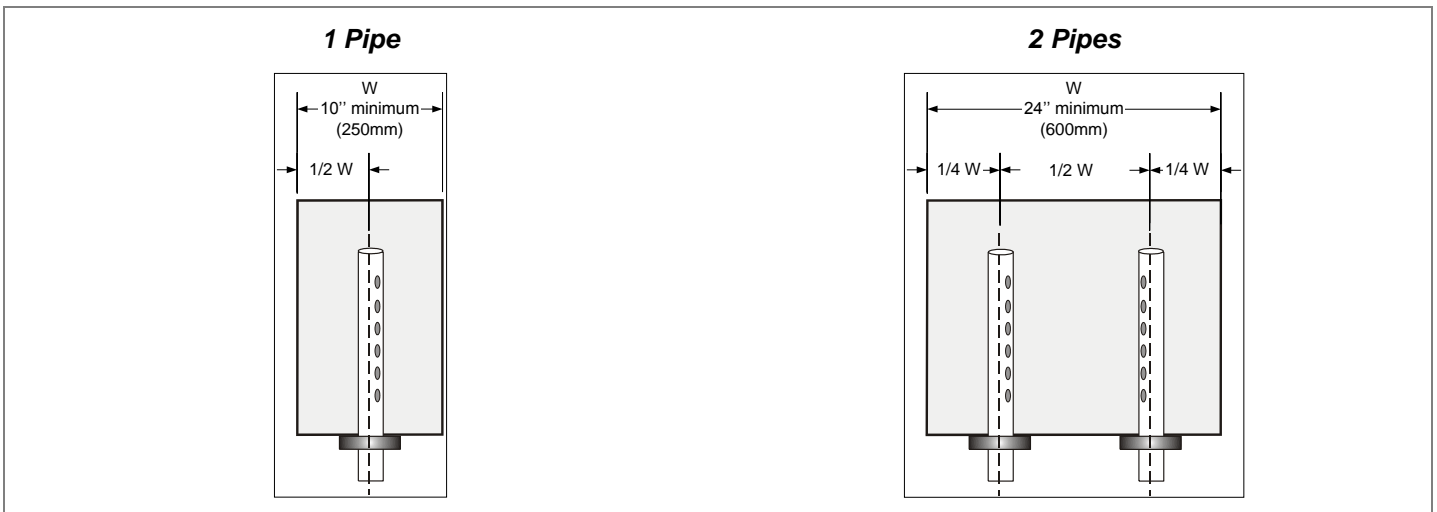

Illustration 14 - 1 3/8" (35mm) Diameter Pipe Placement: Vertical Duct

2 1/8" (54mm) Diameter Pipe

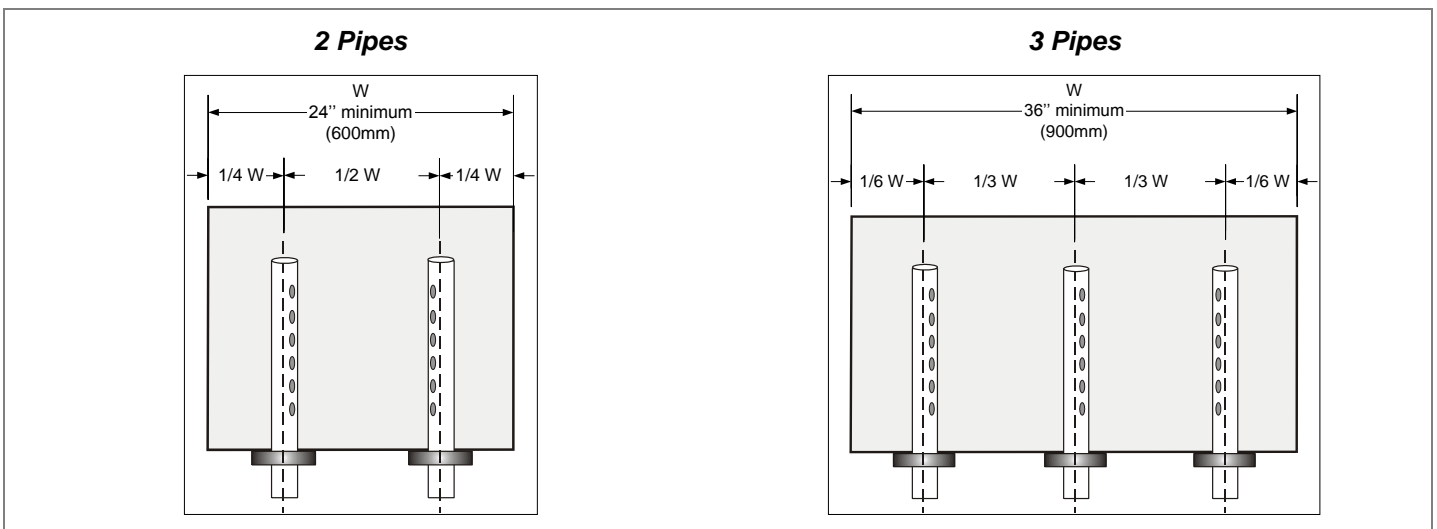

Illustration 15 - 2 1/8" (54mm) Diameter Pipe Placement: Vertical Duct

Steam Output Connections

Installation

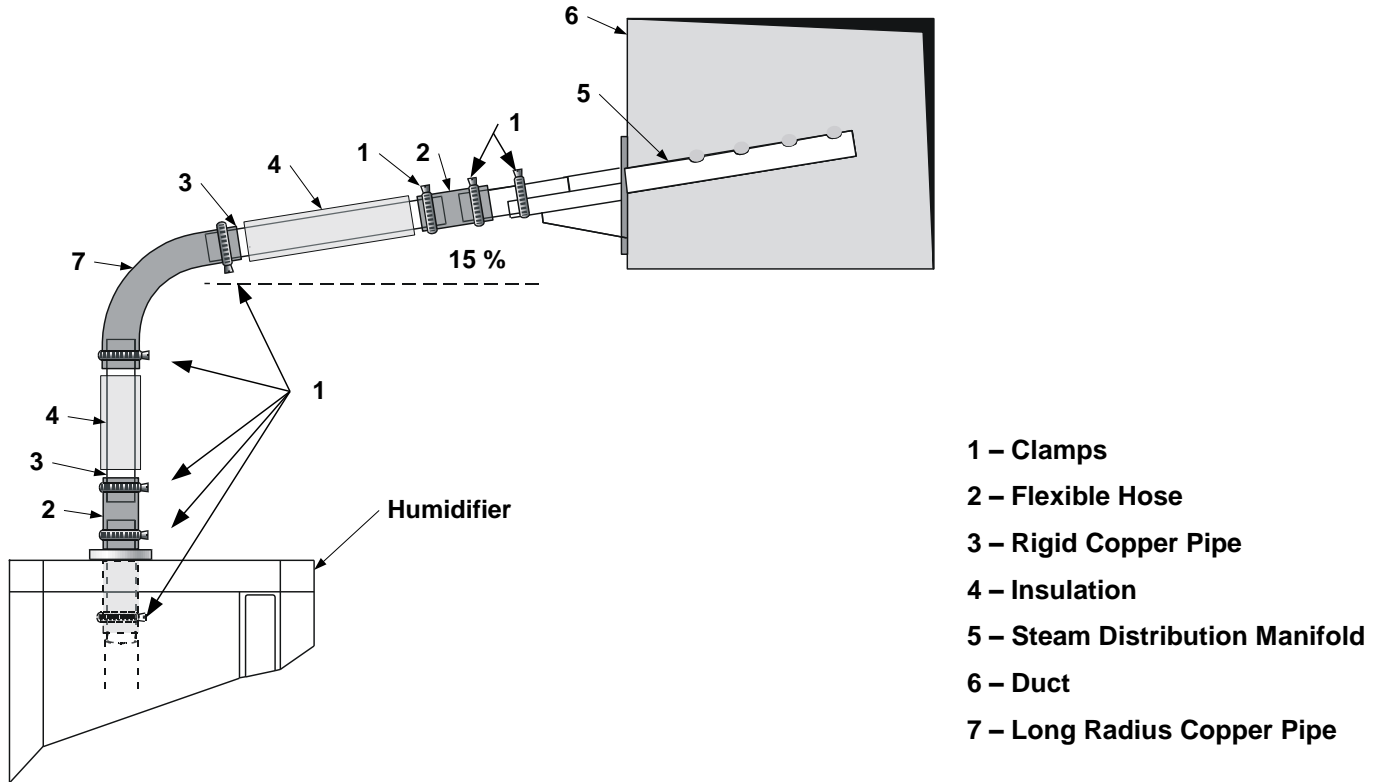

Illustration 16 - Steam Output Connections: Typical Installation

General Recommendations

Follow these general installation rules to avoid any restrictions inside distribution pipes and humidifier evaporation chamber, and also condensation accumulation, which can lead to severe water accumulation in the duct or a humidifier malfunction.



Caution: Risk of malfunction. Avoid kinks, sags, and areas where condensate can be trapped.

- The slope of the steam hose (rigid or flexible) should not be less than 15% (7 horizontal lengths for 1 vertical length) to ensure continuous drainage of condensation back to the humidifier, or a steam trap.
- Use flexible steam hoses for short runs (up to 16 feet or 5 m) or for interconnecting between the rigid pipe runs.
- Determine the total steam line for insulated hard piping based on the capacity of the humidifier such as one equivalent foot for each lb/h capacity of the humidifier (0.67 m for each kg/h) with a maximum of 50 feet (15 m). Consult factory for longer steam line runs.
- If you are using a rigid copper pipe, use insulation to diminish condensate build-up.



S Trap Installation on the Steam Line

- The lowest point of any steam hose or rigid pipe must be the humidifier. If the humidifier cannot be the lowest point of the piping, install a steam trap(s) (S Type) at the lowest point(s) of the steam supply piping. The steam separator (S trap) should be installed higher than the static pressure of the system by at least 2" (51 mm).

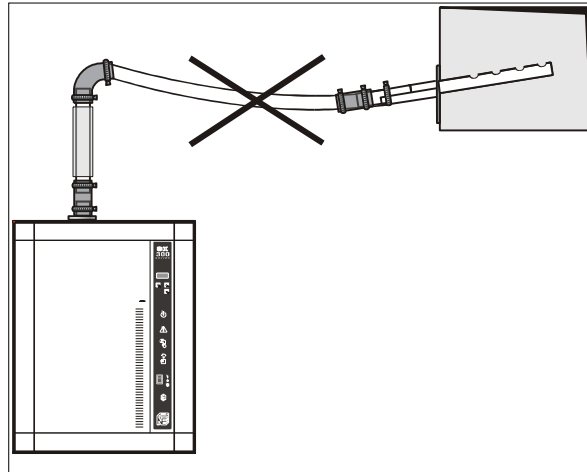

Illustration 17 - Steam Output Connection: Incorrect Installation

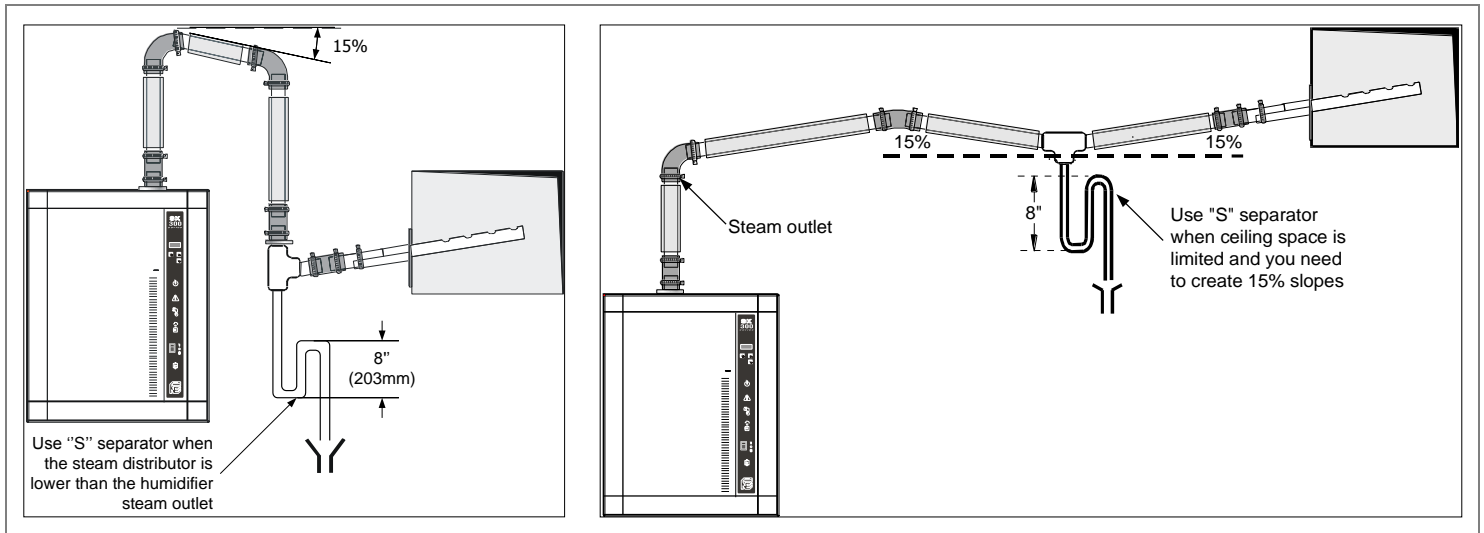
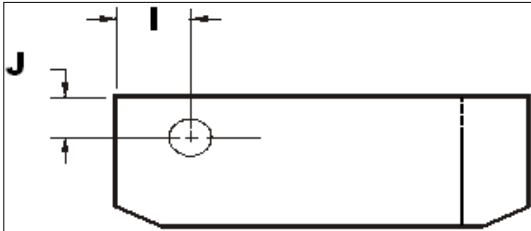

Illustration 18 - Steam Separator (S trap) Installation

Position of Steam Output

Small Cabinet

Models	I	J
SK302 SK304 SK306	4 5/16 (110)	4 13/16 (122)



Medium Cabinet

Models	K	L	M
SK310 SK314	-	4 (102)	5 5/8 (143)
SK316 SK320 SK330	5 9/32 (134)	4 (102)	5 5/8 (143)

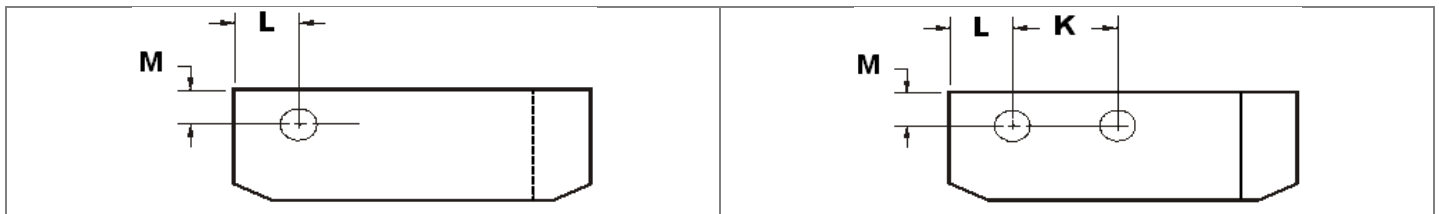

Large Cabinet

Models	N	O	P	Q
SK320 L SK340 SK350 SK360	7 (179)	7 (179)	5 3/16 (132)	5 11/16 (144)

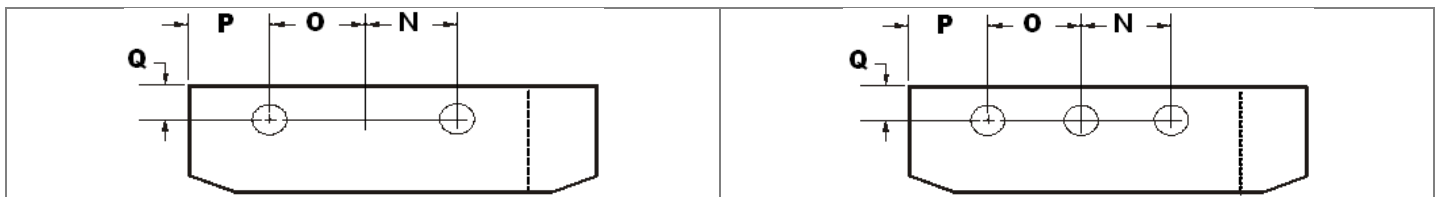

Installation - Humidifier with SDU

- The SDU should be installed in an environment where the air is relatively clean. This avoids the blower from getting clogged with dust.
- The humidifier should be mounted such that the SDU fan section is at least 78" (2 meters) above the floor.
- A minimum clearance of 18" (0.45 meters) from the ceiling should be allocated to avoid ceiling and wall condensation.
- If additional ventilation is not present, the fan should have a clearance from the ceiling of at least 54" (1.35 meters). Proper ventilation must be observed to avoid ceiling and wall condensation.

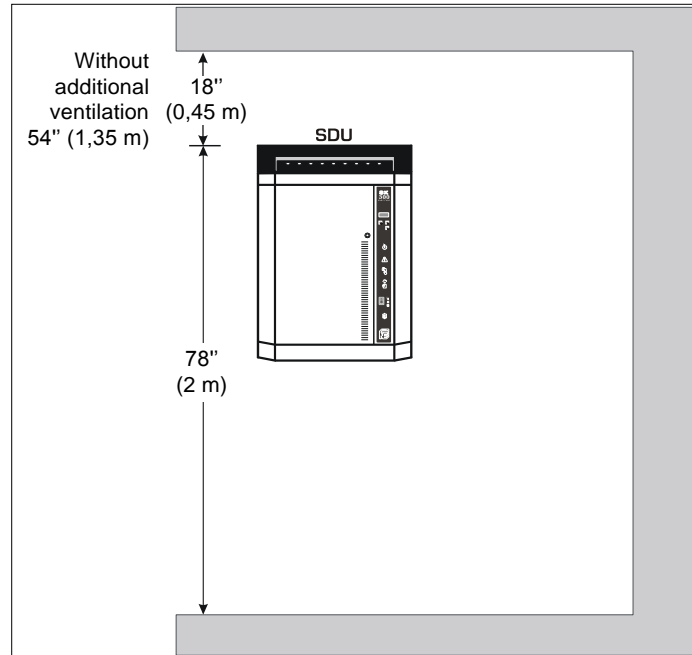

Illustration 19 - SDU mounted on Humidifier

Remote Installation of SDU

The SDU can be installed in a different location from the humidifier (remote SDU). Follow the piping recommendations.

- Mount the SDU to the wall on brackets (not supplied); do not drill mounting holes through the cabinet of the SDU.
- Connect the steam hose(s) to the bottom inlet(s) of the SDU to the top of the steam outlet(s) of the humidifier.
- Secure the hose(s) with the supplied hose clamp.
- Connect the condensate hose to the bottom of the SDU to an open drain.
- Connect the electrical wires from the SDU to the top of the humidifier. Field wiring must conform to local codes.
- The fan of the SDU operates for four minutes after steam production has stopped to prevent condensation.
- Avoid any obstruction of the ventilation openings on top of the SDU.

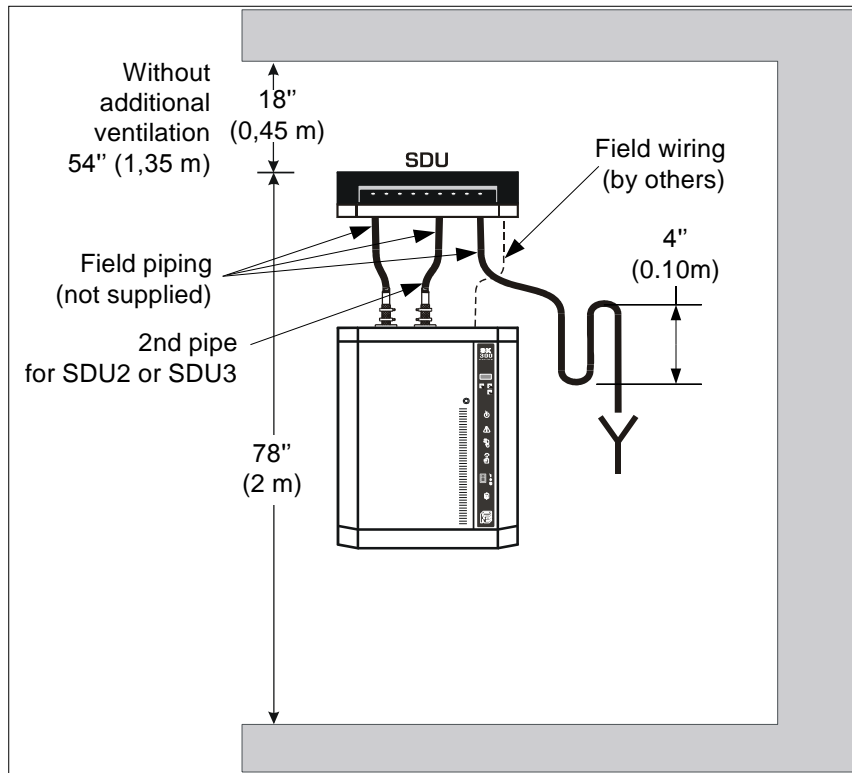

Illustration 20 - SDU Remote Installation

Maintenance of the SDU

Clean the blower if there is an accumulation of dust.

Plumbing Connections



Plumbing Installation should conform to Local and National Codes.
Any installation work must be carried out by suitably qualified personnel.

The SK300 humidifier can operate with soft or hard water. For normal operation, pre-treatment of water is not necessary.

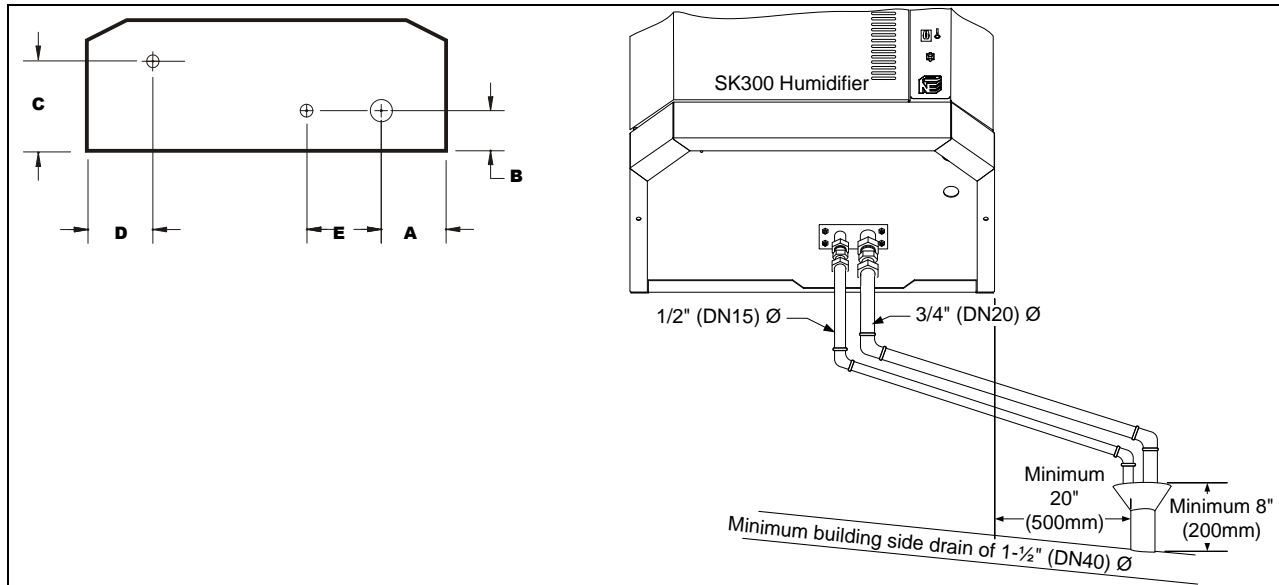

Illustration 21 - Plumbing Connections

Table 6 - Dimensions for Plumbing Connection

Model	Dimensions inches (mm)				
	A	B	C	D	E
SK302 SK304 SK306	6 ½ (165)	2 (51)	9 ⅛ (232)	4 ⅛ (105)	1 ¾ (44)
SK310 SK314 SK316 SK320 SK330	7 ¼ (184)	1 ¾ (44)	9 ¾ (248)	4 ⅛ (105)	1 ¾ (44)
SK320 L SK340 SK350 SK360	7 (179)	1 ¾ (44)	9 ¾ (248)	4 ⅛ (105)	1 ¾ (44)

Water Supply

- Water Inlet Specifications
 - Inlet water pressure: 10 to 70 psig (0.7 to 4.8 bars)
 - Maximum temperature: 85°F (30°C) maximum
 - 3/8" (DN10) standard copper water line connection
- A shutoff valve (not supplied) should be installed in the water supply line close to the humidifier to facilitate servicing.
- It is recommended to install a standard water strainer in the water supply line.
- It is recommended to install a water hammer arrestor, to absorb hydraulic shock and minimize water hammer when the fill valve closes.

Water Connections

Follow the steps below:

1. Connect 3/8" (DN10) copper pipe to the bottom 3/8" (DN10) compression fitting (supplied).
2. Place the swivel top 3/4" (DN20) fitting to the male threaded part of the valve and tighten it with fingers.



Caution: Risk of damage to the valve. Do not use a wrench to tighten swivel.

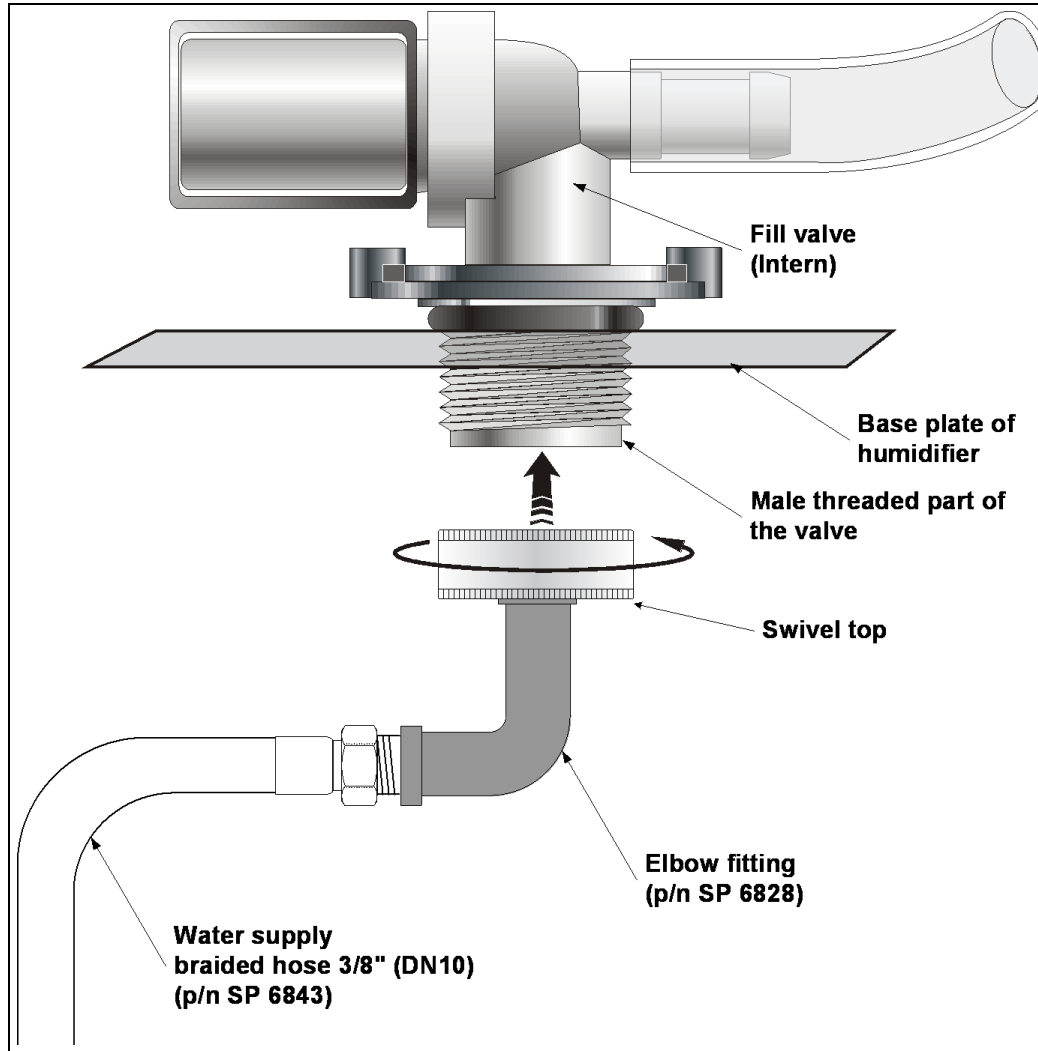

Illustration 22 - Water Supply Connections

Drain Connections

- Evaporation chamber water drain temperature: 140°F (60°C).
- Standard hydraulic compression fittings: a 3/4" (DN20) for the evaporation chamber drain and a 1/2" (DN15) for the pan drain.
- 2 hydraulic pipes located under the humidifier (see Illustration 21 - Plumbing Connections) must be connected to the drain pipe.
- Use standard copper hydraulic pipes 3/4" (DN20) and 1/2" (DN15).
- Ensure that the drain pipe dimension is sufficient, especially if more than one humidifier is evacuating into the same drain line.



Weather Proof Enclosure Plumbing Connection

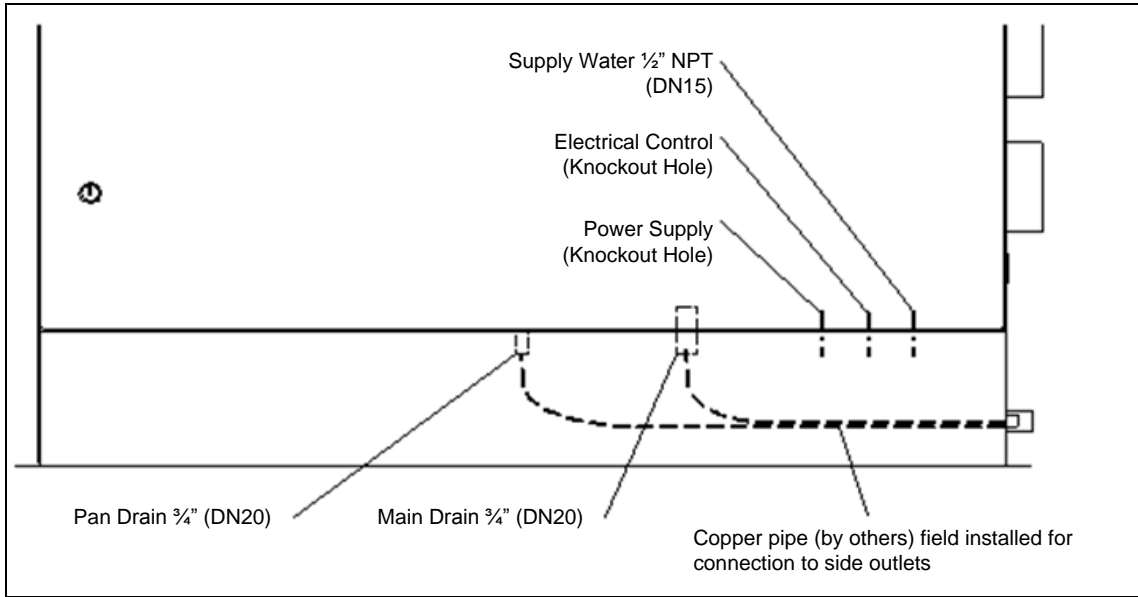

Illustration 23 - Weather Proof Enclosure Plumbing: Front View

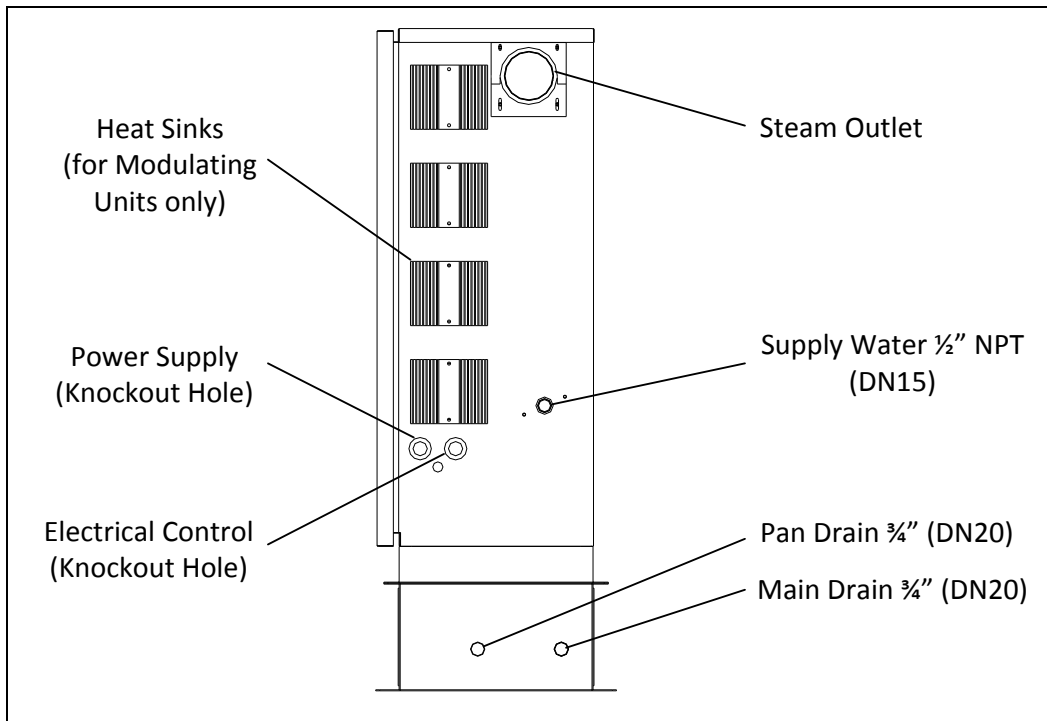

Illustration 24 - Weather Proof Enclosure Plumbing: Side View

Water Drain Valve

The weather proof enclosure is equipped with a normally open valve, enabling the humidifier to drain all water during a power failure, to prevent water from freezing within the unit. During normal operation, the humidifier reduces drain water temperature to 140°F (60°C).



Caution: During a power failure, the drain water temperature is not reduced. Installed drain piping must be rated to 212°F (100°C).



Power Supply Connections



Caution: Risk of electric shock. Disconnect the Humidifier from the electric supply before proceeding with the connection.



WARNING: Risk of fire. Do not interchange the power terminal block designated L1, L2 and L3 with low voltage terminal block designated 1, 2 and 3.

- The wiring to the humidifier should be done by a qualified electrician, and should conform to the procedure, regulation and local codes.
- Use only copper conductors.
- An external over current protection and disconnect circuit breaker should be installed on the supply, adjacent to the humidifier.
- A knock-out (not supplied) should be installed at the bottom of the electrical compartment of the humidifier for strain relief of the supply cable.
- Ensure that the size of the wire conductors is appropriate for the current supplied.
- Ensure that each terminal connection is properly secured.
- The ground conductor should be equipped with a ring terminal and should be connected directly to the electrical panel on the indicated location.

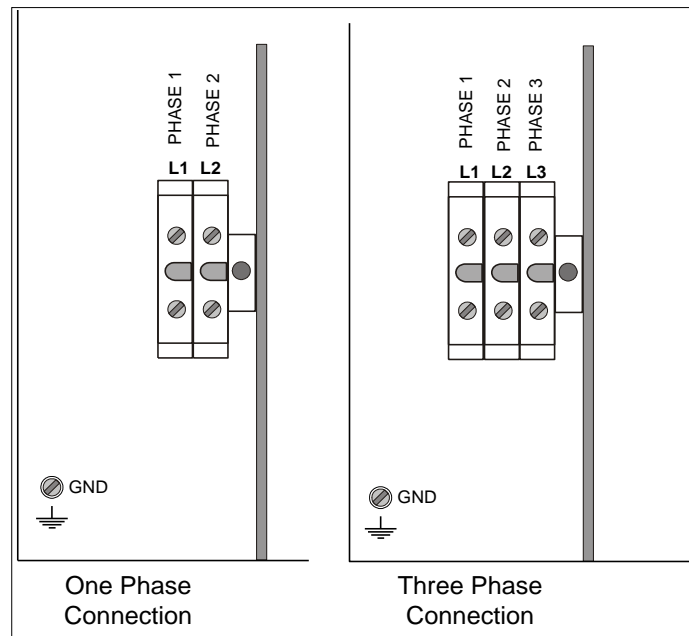

Illustration 25 - One and Three Phase Power Connections

Low Voltage Control Connections

ON/OFF Humidifier

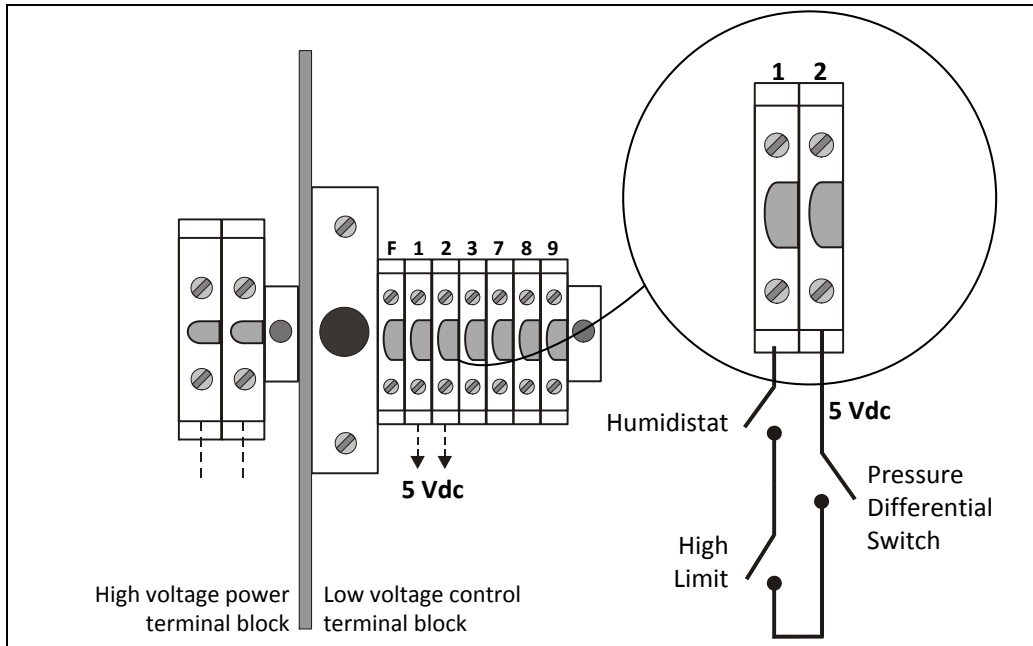

Illustration 26 - Low Voltage Control Connections

Modulating Humidifier

Humidity Control by Humidistat (External Mode)

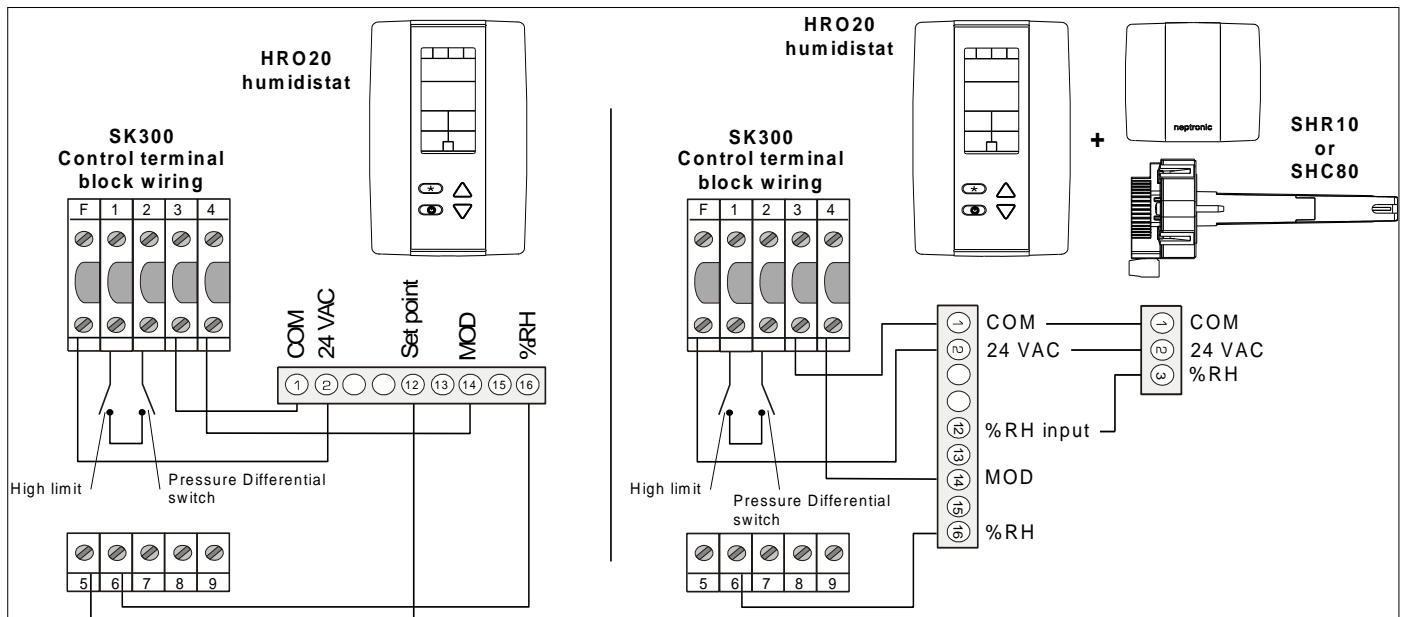

Illustration 27 - Connection to HRO20 humidistat or HRO20 with remote humidity sensor (SHR10 or SHC80)

Humidity Control by Humidifier (Internal Mode)

Humidity is controlled by the humidifier, using SHR10 or SHC80 as space sensor.

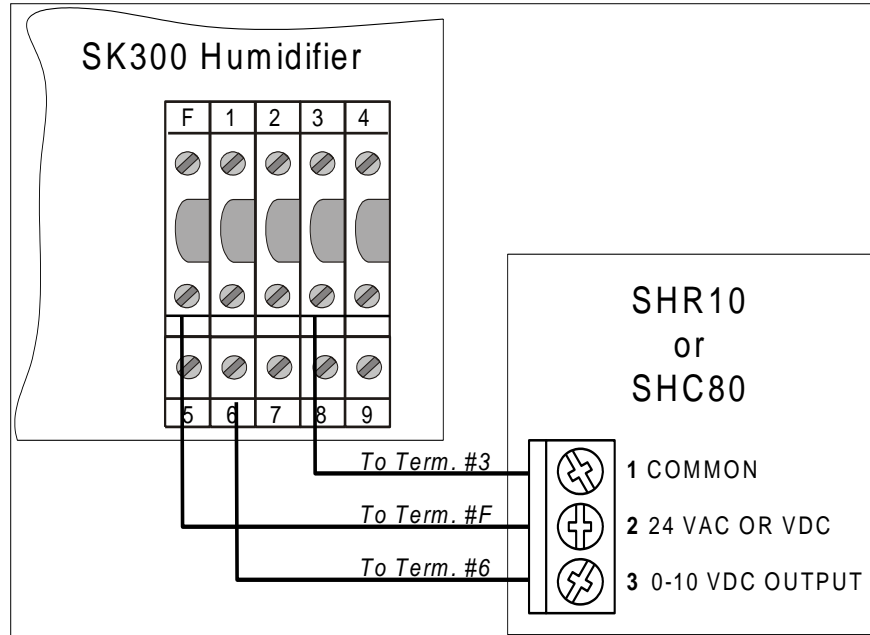

Illustration 28 - Humidity controlled by humidifier with SHR10 or SHC80 as space sensor

VAV system with humidity controlled by the humidifier, using SHC80 as Hi-limit duct sensor and SHR10 or SHC80 as space sensor.

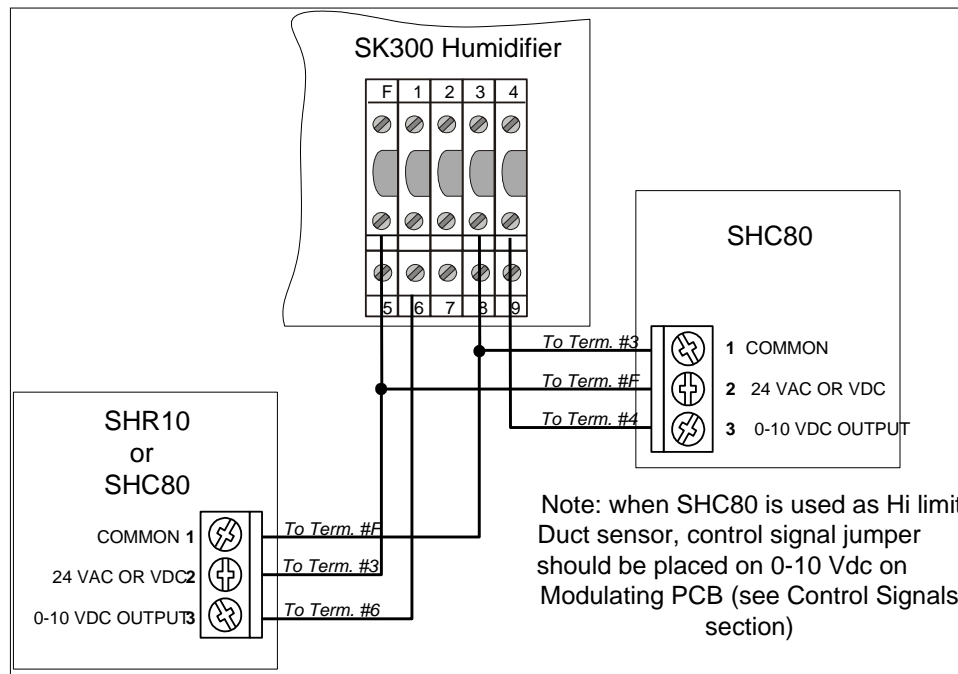

Illustration 29 - VAV system with humidity controlled by humidifier using high-limit sensor and space sensor

Humidity Signals (Internal Mode)
Humidity Signal 0-10 Vdc

Illustration 30 - Humidity Signal 0-10 Vdc

Humidity Signal 2-10 Vdc

Illustration 31 - Humidity Signal 2-10 Vdc

Humidity Signal 4-20 mA

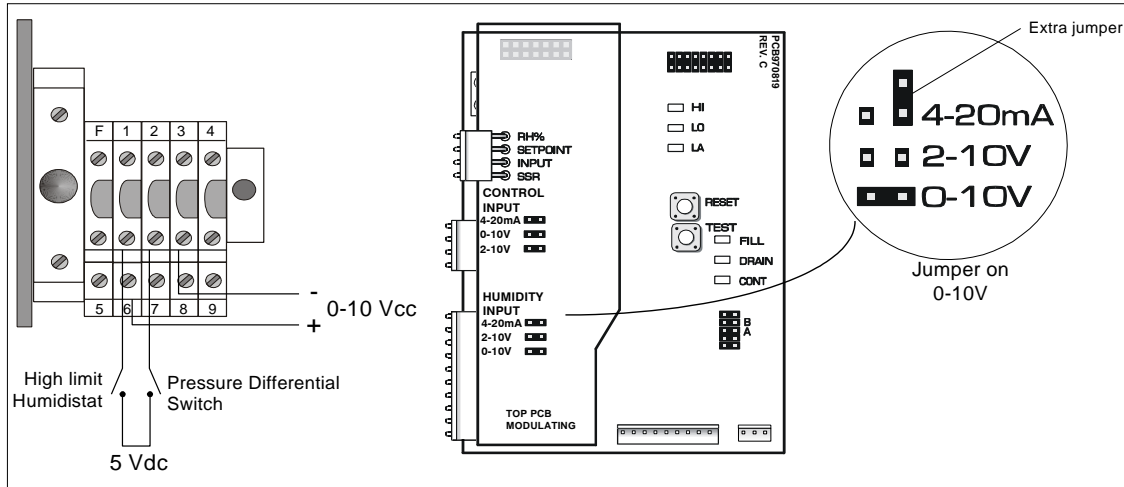
Illustration 32 - Humidity Signal 4-20 mA

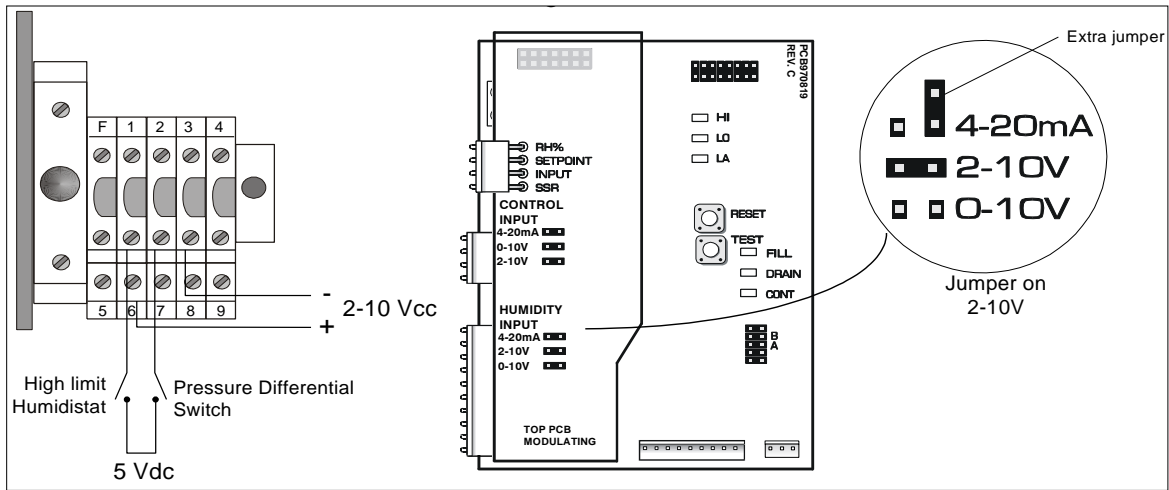

Control Signals

Control Signal 0-10 Vdc

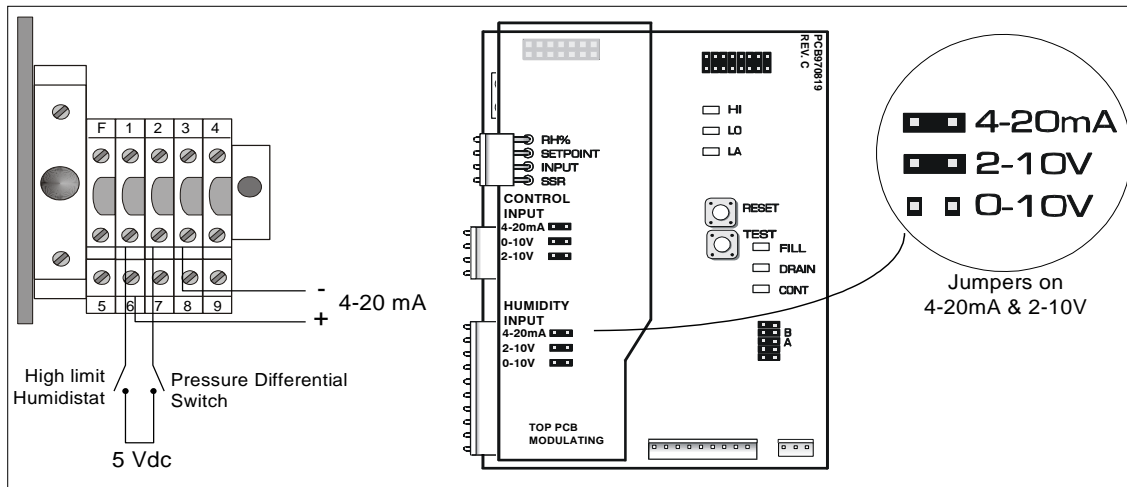
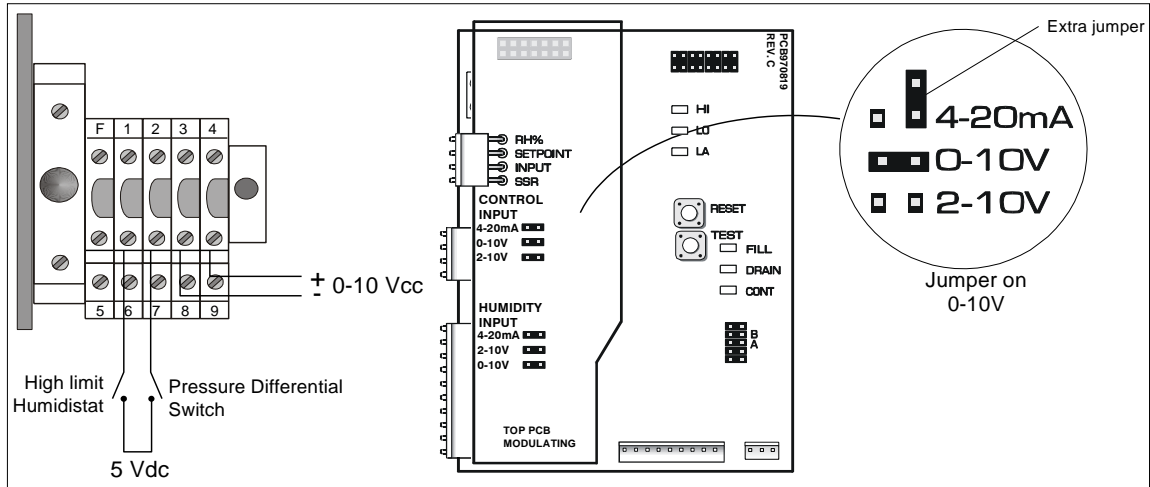

Illustration 33 - Control Signal 0 to 10 Vdc

Control Signal 2-10 Vdc

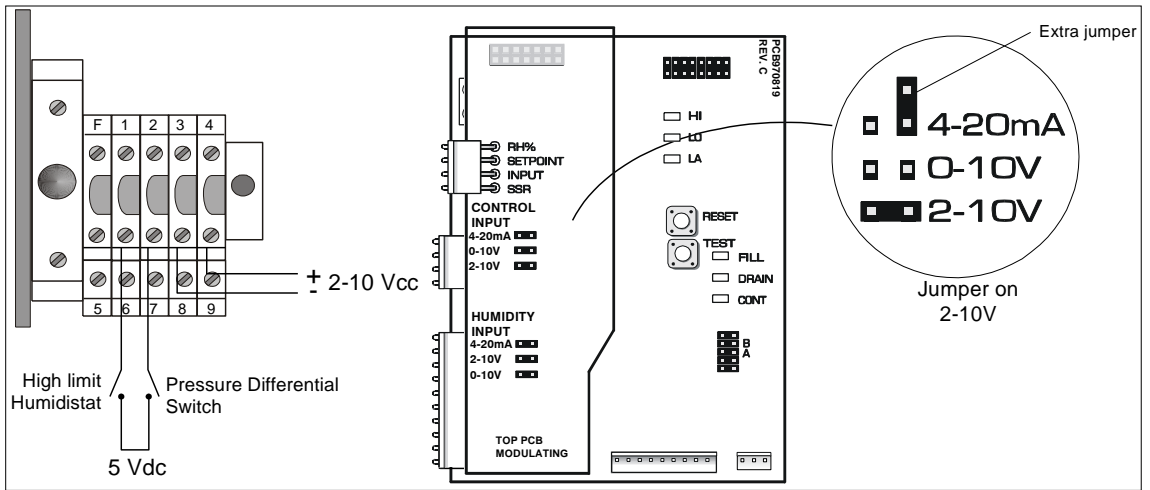

Illustration 34 - Control Signal 2 to 10 Vdc

Control Signal 4-20 mA

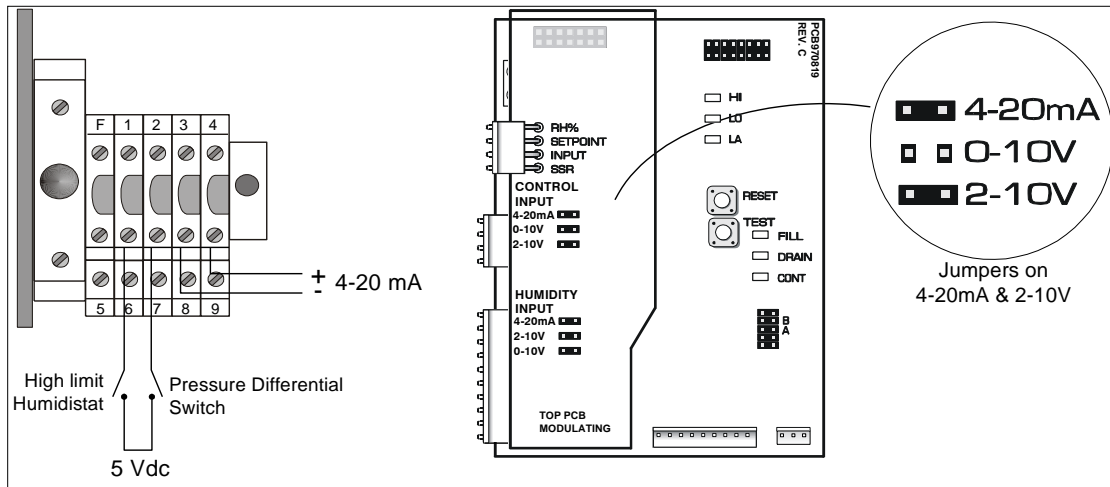

Illustration 35 - Control Signal 4-20 mA



Common Alarm Connections

- A volt free contact is provided in the form of both a Normally Open and Normally Closed contact that switches on, in the event an alarm is activated on the SK300 humidifier.
- When possible, we recommend using the Normally Closed contact. This contact opens in the event of a humidifier fault.
- Used to switch a low voltage, ideally 24V, with a switching current of no more than 3 Amps.

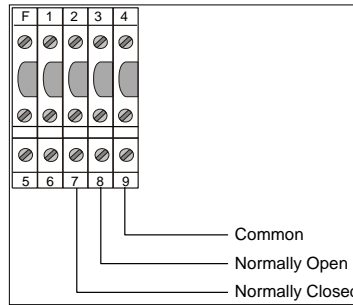

Illustration 36 - Common Alarm Connections

Controls Placement (Steam Dispersed into a Duct or AHU)

A typical humidifier control system should include the following along with the humidifier:

- A wall or return duct humidistat
- A high limit duct humidistat
- An airflow switch

Placement of these devices is critical to the proper operation of the overall system.

- The return duct humidistat must always be located before any outside air intake, to ensure accurate sensing of the air from the humidified space.
- Alternatively, a room humidistat can be used. The room humidistat should be located on an inside wall or column. It should not be near any discharge air from supply ducts or sources of heat or cold.
- The airflow switch must be positioned to accurately open on a loss of air flow, to prevent the humidifier from running when there is no air to absorb humidity.
- The high limit humidistat must be positioned far enough, minimum 15ft (4.6m), downstream of the steam dispersion manifold(s) to prevent it from getting wet, but still allows it to accurately prevent over humidification of the duct that could result in condensation.

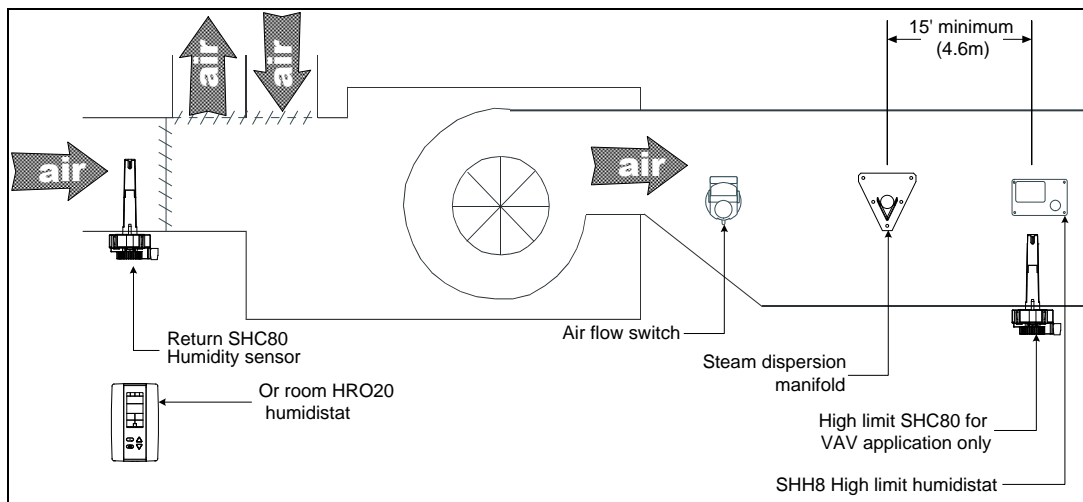

Illustration 37 - Controls Placement (Steam Dispersed into a Duct or AHU)

Display

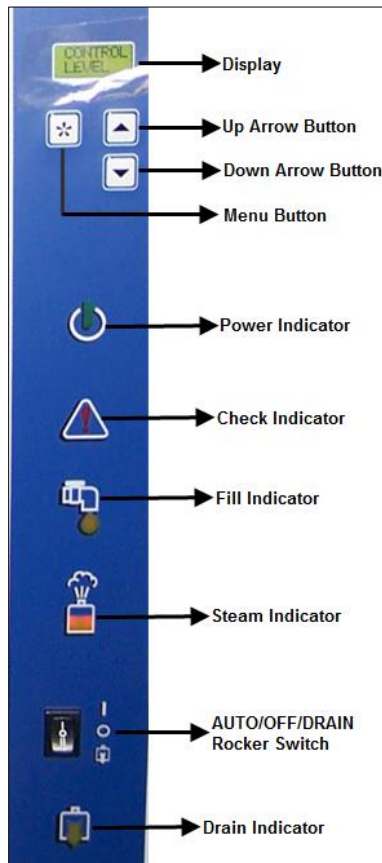











Illustration 38 - Display Features: Front Panel

Front Panel

The following are the display features of the Front Panel and their description:

Table 7 - Humidifier Front Panel Display Description

Options		Description
Display		The Alphanumeric display indicates all the operation parameters and error messages.
Menu Button		The menu button is used to access Programming mode.
Up and Down Arrow Buttons	 	▲ - Used to increase the control parameters of the humidifier. ▼ - Used to decrease the control parameters of the humidifier.
Power Indicator		⚡ - The humidifier is powered by electricity and the Rocker switch is at the AUTO position. O - The humidifier is disconnected from the power supply.
Check Indicator		⚡ - The CHECK indication is normally off. It will be activated as a warning during abnormal conditions of operation. ⚡ (blinking) - If the CHECK indication is on, it means that maintenance is required. The running hours have exceeded the Service hours. See Service section on page 37. O - No abnormal conditions of operation.

Options	Description
Fill Indicator 	☀ - Indicates that the water supply (fill) valve is open. O - Indicates that the water supply (fill) valve is closed.
Steam Indicator 	☀ - For ON/OFF models, the STEAM indicator is ON when the contactor is closed and steam is being generated. ☀ (blinking) - For modulating models, the STEAM indicator blinks ON and OFF in proportion to the percentage of steam output percentage the humidifier is generating. This proportion appears on the display. When the output reaches 100%, the indicator stops flashing. O - Indicates that steam is not being produced.
Rocker Switch AUTO/OFF/DRAIN 	AUTO - Position AUTO (I) The humidifier generates steam based on demand from the humidistat. OFF - Position OFF (O) - Humidifier will shut off. DRAIN - Position DRAIN The humidifier stop operating and the evaporation chamber drains the water out. This is done typically at regular service.
Drain Indicator 	☀ - Indicates that the drain pump is on, either as a result of an automatic drain cycle or because the front panel Rocker switch is manually set to DRAIN. O - Indicates that the drain pump is off.

Modes – Description

OFF Mode

When the Rocker switch is in the OFF position, the display shows the model of the humidifier and the program version number as follows:

NEP 3.4
SK310M

Scroll Mode

When the Rocker switch is in the AUTO position, the display scrolls the following information every 6 seconds:

Table 8 - Scroll Mode Display Description

Display and Description	Notes
RH 25% DCT 68% Display Space and Duct Relative Humidity readings	Only on modulating humidifiers (suffix M). If no High limit Duct sensor is installed, the second line is left blank.
LB/HR 30 Quantity of steam produced by the humidifier	The actual output of the humidifier at that moment is 30 lb/hr.
ALARM LEVEL Low water level	Below this water level, the humidifier shuts off and the water supply valve is activated until sufficient level is reached.
CONTROL LEVEL Water level is controlled	The water supply valve is activated below this level.
HIGH LEVEL Water at maximum level	The water supply valve is automatically deactivated.



List of Alarms

When the following conditions occur, the diagnostic messages override the scrolling information:

Table 9 - List of Alarms

Display	Description
<i>NO DEMAND</i>	Modulating humidifier: No analog signal to the humidifier.
	On/Off humidifier: <ul style="list-style-type: none"> • Humidity level has exceeded the setpoint of the humidistat or • Humidity level has exceeded the setpoint on the high limit humidistat or • Airflow is not detected by the air pressure switch
<i>SAFETY OPEN</i>	<ul style="list-style-type: none"> • Humidity level has exceeded the setpoint on the high limit humidistat • Airflow is not detected by the air pressure switch (modulating humidifier only)
<i>DRAIN CYCLE</i>	The humidifier is in the automatic drain mode.
<i>CONTACT DELAY</i>	15-second delay for the power contactor to be activated.
<i>OVERHEATED</i>	The temperature inside the container has exceeded the boiling temperature. The humidifier has shut off automatically.
<i>PROBE DEFECTED</i>	The water level sensor is not operational. The humidifier has shut off automatically.
<i>NO LEVEL</i>	Water has not reached the level probe. This message appears when turning on the humidifier if the evaporation chamber is empty.
<i>FOAMING CYCLE</i>	The Anti-Foam Energy Conservation (AFEC) has detected foam. The humidifier drains for a few minutes and returns to normal operation.
<i>DRN/PROB BLOCK</i>	The humidifier drains but the water level does not decrease, the humidifier has automatically shut off.
<i>VERIFY RH SENS</i>	The signal from either SHR10 or SHC80 used as space sensor is lower than 0.49 Vdc to terminal # 6 of the humidifier. There might be a connection problem or a defective sensor.
<i>VERIFY DCT SENS</i>	The signal from SHC80 used as Hi limit duct sensor is lower than 0.49 Vdc to terminal # 4 of the humidifier. There might be a connection problem or a defective sensor.

Programming Mode

To access the Programming Mode, push the  button. To move to the next program function, push the button twice. Use the  and  buttons to make any selection.

The changes made in the Program Mode are saved into a non-volatile memory. When the humidifier is in the menu driven Program Mode, the normal operation of the humidifier is halted. To resume normal operation, exit the menu program mode by pressing the  button until the alphanumeric display is clear.

1. "SETPOINT OUT 30%"

Default: Out 30%
 Range: 00 to 100%
 Out: Output setpoint to HRO20
 Int: Internal

To enable the humidifier display, perform the following steps:

- a. Press the  and access the RUNNING function, Step 5, "Running 0645 Hrs. The RUNNING message appears.
- b. Press and hold the TEST button located on the main PC board inside the electrical compartment for 10 seconds.
- c. Release the TEST button and then press the RESET button on the same main PC board. Setpoint is now displayed on the humidifier display.
- d. If the output is selected, the setpoint is sent from the humidifier to the humidistat HRO20.
- e. If SHR10 or SHC80 is connected with humidifier, select Internal, as this allows you to set up RH setpoint directly from the humidifier.
- f. To switch between the output and internal setpoints, press and hold the TEST button located on the main PC board inside electrical compartment till the value changes.

2. "SETPOINT VAV OFF"



Default: OFF (Duct humidity control disable)

Range: OFF (Duct humidity control disable), High limit duct humidity setpoint value (65%)

This option appears only if you have selected Internal at Step 1, "Setpoint out 30%. Set the VAV value setpoint.

If the setpoint VAV is set to OFF, humidity signal from the VAV duct will not be considered. If the setpoint VAV is set, the humidity output will be controlled by both the space demand and high limit duct humidity signal.

To add a setpoint VAV value, perform the following steps:

- a. Press and hold the TEST button located on main PC board, inside the electrical compartment until OFF disappears.
- b. Select the VAV setpoint desired value by using the  and  buttons on the control panel.

3. "PROP BAND 3%"

Default: 3%

Range: 3% to 9%

This option appears only if you have selected Internal at Step 1, "Setpoint out 30%. Select the desired value for proportional deadband.

Select the desired proportional band value by using the  and  buttons on the control panel.

4. "DRAIN 4 HRS"

Default: 4 hours

Range: 1 to 24 hours



Increment: 1 hour

Select the frequency for drain cycle. Generally, the harder the water is, higher the drain cycle frequency should be. Drain cycle setting does not affect the AFEC system.

5. "RUNNING 0645 HRS"

Number of running hours (information display only)

Indicates the number of hours the humidifier has been running since the last servicing.

After every service, reset the number of hours of operation to zero by pressing the ,  buttons simultaneously for 15 seconds. This resets the number of hours of operation to zero.

6. "SERVICE 1000 HRS"

Default: 1000 hours

Range: 400 to 1500 hours

Increment: 100 hours

Set the number of hours of operation before the humidifier calls for servicing. Generally, the harder the water is, the lesser the number of hours of operation before servicing can be initiated.

7. "LOCK ON 80% PWR"

Default: 100 %

Range: 0% to 100%

Increment: 1%

Select the output span, the rate at which the humidifier delivers 80% of the maximum rated output at full demand.

Control P.C. Board

The Printed Circuit board designated "PCB970819" is common to all SK300 series humidifier, ON/OFF or modulating humidifier. This PC board is equipped with an advanced microprocessor, which controls all the humidifier functions. The Printed Circuit board which is directly connected onto the main PC board is installed only on modulating model (suffix M).

Main P.C. Board

There are three water level L.E.D.s on the upper right-hand side. They indicate the relative water height as sensed by the water level sensor.

- If **HI** is illuminated, the water supply valve shuts off.
- If **LO** is off, the evaporation chamber filling is ordered, and water supply valve opens.
- If **LA** is off, no water is detected by the water level sensor, the power to the elements is disconnected.

The three status L.E.D.s at the center left side operate as follows:

- **FILL** - Indicates that the water supply valve is feeding water.
- **DRAIN** - Indicates that the drain pump empties the container.
- **CONT** - Indicates that the power is supplied to the elements and the humidifier is producing steam.

The **TEST** button should be used when commissioning the humidifier; this initiates a pre-programmed start-up cycle. The start-up cycle cleans the supply water and the evaporation chamber (see Start-up Procedure section). This button also enables the setpoint control of the humidistat to humidifier display (see Programming Mode section).

The **RESET** button enables to bypass the start-up sequence.

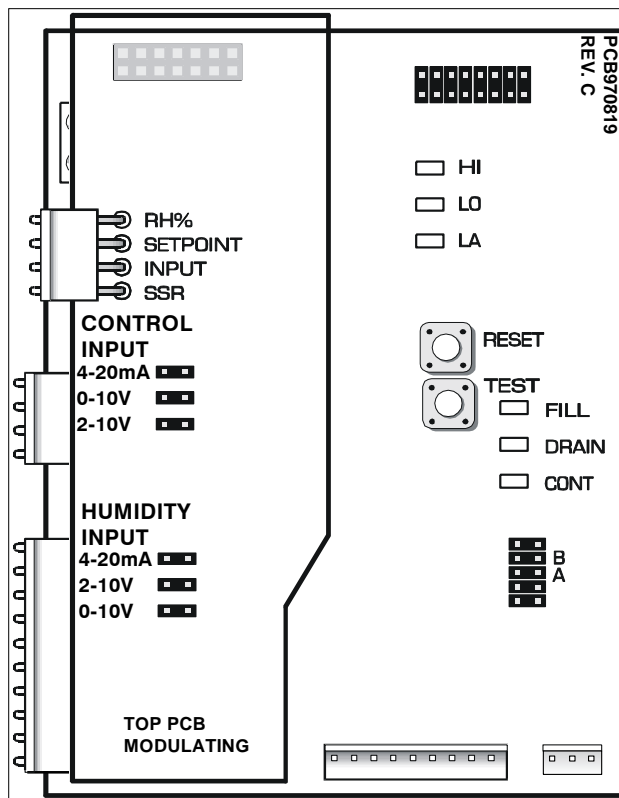

Illustration 39 - Main PC Board



Modulating P.C. Board

- The three jumpers at the center of the PC board (Control Input) are used for selecting the incoming control signal. For more information, refer to the Control Signals section.
- The three jumpers at the bottom of the PC board (Humidity Input) are used for selection of the incoming humidity signal. For more information, refer to the Humidity Control by Humidifier (Internal Mode) section.

Start-up Procedure

We recommend to strictly following this Start-up procedure to avoid any anomaly resulting from wrong cleaning of the components. In the case of a problem or discrepancy, see the Troubleshooting section.

1. Ensure that the mechanical, electric and plumbing connection are done and secured.
2. Ensure that the low voltage control circuit is done and correct.
3. Turn the water shutoff valve on (outside the humidifier) and check that the drain connections are connected to the main drain line with sufficient diameter.
4. Turn the power on to the humidifier from the circuit breaker disconnect switch. The POWER indicator should be on.
5. Push the TEST button located on the main PC board. This PC board is located in the electrical compartment.
This will start up a pre-programmed start-up cycle. This start-up cycle will test functions of the humidifier and will flush out any dirt in the humidifier and supply lines. This cycle lasts for about one hour.
 - o The front panel Rocker switch will not affect the performance of the start-up cycle.
 - o In the case of modulating humidifier, there must be a demand signal of at least 50% for the start-up cycle to operate correctly.
 - o To bypass the start-up cycle at any time and proceed to normal operation, press the RESET button located on the main PC board.
6. The front panel Rocker switch may be left in the AUTO position during the start-up cycle. This will result in normal operation of the humidifier as soon as the start-up cycle is finished. Your humidifier is now fully operational.

Service

The humidifier requires a regular maintenance service to ensure efficient and trouble-free running. Regular service involves cleaning the evaporation chamber and its components manually. Frequency of cleaning can range from 2 months to once in a year. However, the cleaning frequency depends on the following specific factors:

- Quality of water
- Frequency of automatic drain cycles
- Demand placed on the humidifier

All SK300 humidifiers are programmed for a 1000 hours of operation. This is a default factory setting.

To view the number of hours the humidifier has run and the number of service hours, press the menu  button on the front panel several times till you view the information on the digital display.



At the end of 1000 hours of operation, the red LED  on the front panel starts blinking on off continuously. This indicates that the humidifier is due for service. Though the humidifier continues to run, it is important to service the humidifier at the earliest.

Clean the Evaporation Chamber

Cleaning the Evaporation Chamber involves the following steps:

Stage 1 - Shut down electrical supply and disassemble the humidifier





Stage 2 - Remove and clean the evaporation chamber

Stage 3 - Reassemble the evaporation chamber

Stage 4 - Restart the humidifier

Pre-requisite for cleaning the Evaporation Chamber

Before you commence the cleaning procedure, ensure that the evaporation chamber is cool and comfortable to handle as the evaporation chamber and its contents can be extremely hot and can cause burning. If it is hot, allow the evaporation chamber to cool by initiating a drain cycle.

1. Press the Rocker switch to the drain down position . The humidifier initiates a drain cycle and empties the evaporation chamber.
2. Press the Rocker switch upward to the Auto (I) position . The humidifier fills the evaporation chamber with water. The Fill  light is illuminated.
3. Press the Rocker switch to drain down position  again to empty the chamber.

At the end of the drain cycle, check the temperature of the evaporation chamber. To check the temperature, open the front door of the humidifier and touch the chamber with the back of your hand. If it is cool enough to handle, shut down the electrical supply. If not, repeat the drain cycle till it is cool enough. If further drain cycle is not required, press the Rocker switch to OFF (O) position.

Stage 1 - Shut down electrical supply and disassemble the humidifier



Caution: Risk of electric shock. Shut down the electric supply of the humidifier. Disconnect the power at the External Breaker/Fused Disconnect before commencing servicing

1. Press the Power  button on the control panel to switch off the humidifier.
2. Remove the power supply to the humidifier at the disconnect switch or the breaker.
3. Disconnect the power connector to the heating elements.

Model	Method
SK302 to 306	Unscrew the connector
SK310 to SK360	Squeeze the locking ears of the high voltage connector and pull it apart

4. Remove the clip-on level sensor board located on the chamber cover.
5. Disconnect the wire connector to the high-temperature safety cut-out.
6. Loosen the steel clamps that hold the steam hose in place with a 5/16" (8mm) nut driver or a standard screwdriver.
7. Loosen the compression brass connectors using an adjustable wrench and an 11/16" (17mm) key. Unscrew the brass nut and slide it back.

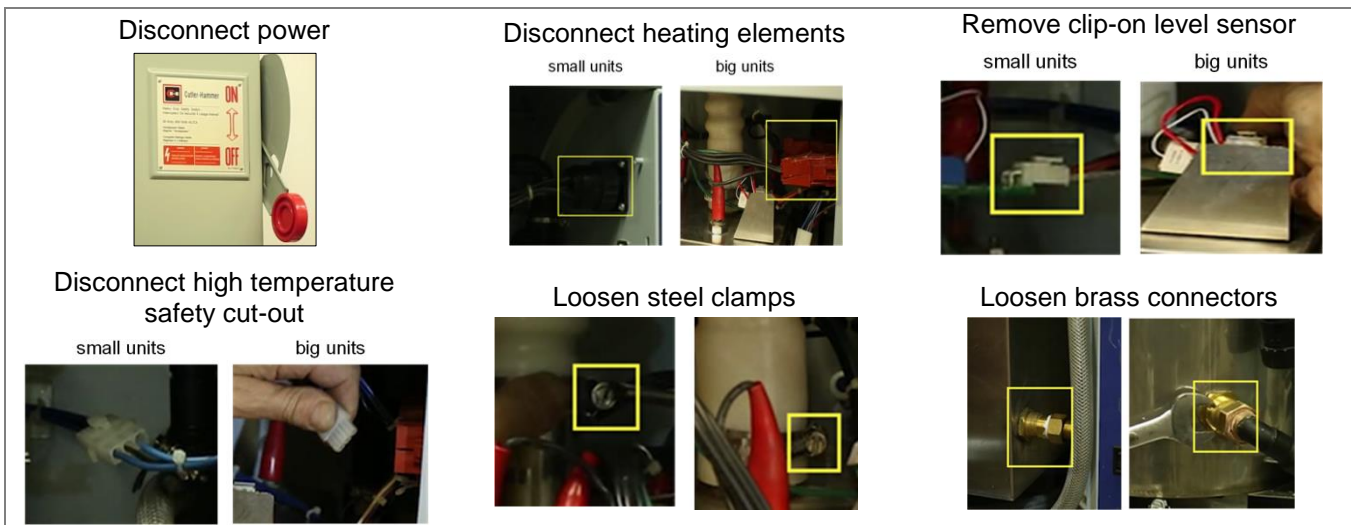

Stage 2 - Remove and clean the evaporation chamber

1. Slide out the boiling chamber.



The evaporation chamber still contains few inches of water, tilt it slightly to ensure that you do not spill this water on yourself.

Ensure that your footing is secure when lifting the evaporation chamber. Evaporation chambers in large humidifiers such as SK340 and SK360 may weigh more than 35 lbs (15 kgs). Seek assistance from another person while removing the chamber.

2. Uncouple the clamp connectors.

Model	Method
SK302 to 306	Unlatch the three latches located around the evaporation chamber.
SK310 to SK360	Turn the four or eight latches located around the evaporation chamber.

3. Open the lid along with the elements inside.



The heating elements are self-cleaning. Any mineral accumulation breaks off and falls to the bottom during operation.

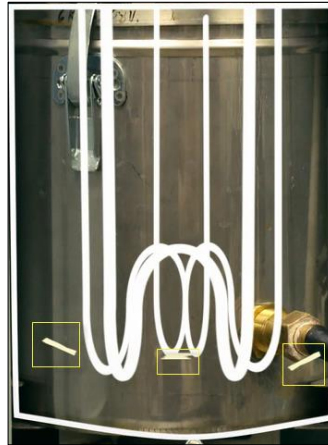

Illustration 40 - Metal deposit dislodge during operation

- Remove the residue that has accumulated inside the chamber.
- To clean out the remaining scale from the container, use a stiff brush (synthetic filament only) and some vinegar or any weak acid suitable for cleaning stainless steel.



WARNING: The use of a wire brush or any non-recommended acid will void the warranty.

- The components installed on the cover (heating elements and water level sensor) and the cover itself should be cleaned as necessary, only if some scale has been accumulated on them.
 - Do not scrape off the walls of the chamber.
 - Ensure that the fill drain aperture is not blocked.
4. Check the gasket and ensure that it is in good shape. Replace the gasket if it is dry, torn or hardened.
5. Replace the lid back on the chamber.

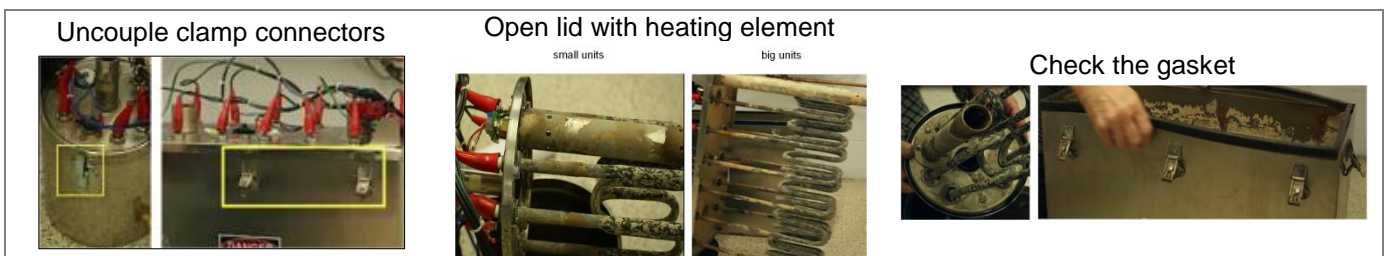

Water Level Sensor

The water level sensor is encased in a chamber that protects the sensor.

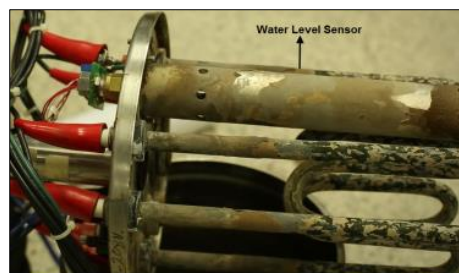

Illustration 41 - Water Level Sensor

To clean the sensor, perform the following steps:

1. Remove the chamber from the unit by unscrewing the two screws that hold the chamber. These screws are located on the chamber itself.
2. Remove the chamber carefully without touching or damaging the water level sensor.
3. Clean the sensor using a soft cloth.



The water level sensor is covered by a thin layer of Teflon. Any scratch or damage to this layer results in malfunctioning of the humidifier.

4. Clean the protection chamber in the same way as the evaporation chamber.
5. Reattach the chamber to the cover by tightening the screws on top of the cover.

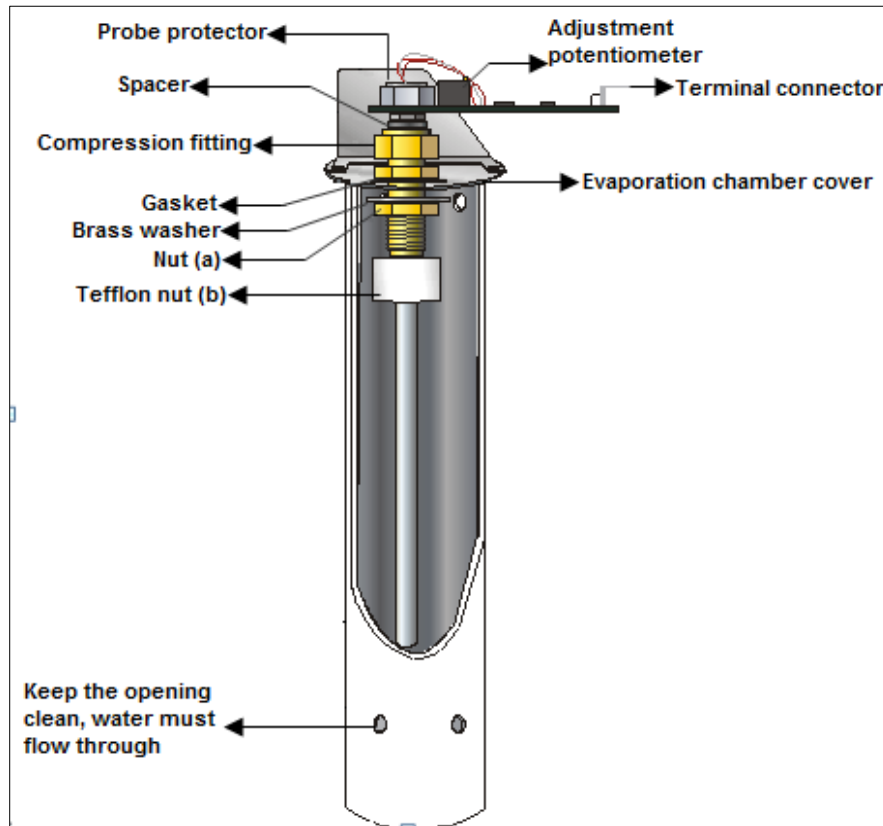

Illustration 42 - Water Level Sensor and Protection Chamber

Stage 3 - Reassemble the humidifier

1. Mount the boiling chamber back into the unit.
2. Tighten the compression brass connectors.
3. Reconnect the steam hose.
4. Reconnect the clip-on level sensor.



Reconnect the clip-on level sensor only when the power is disconnected. If, for any reason, you did not connect the level sensor during the reassembling, ensure to disconnect the power first, and then reconnect.



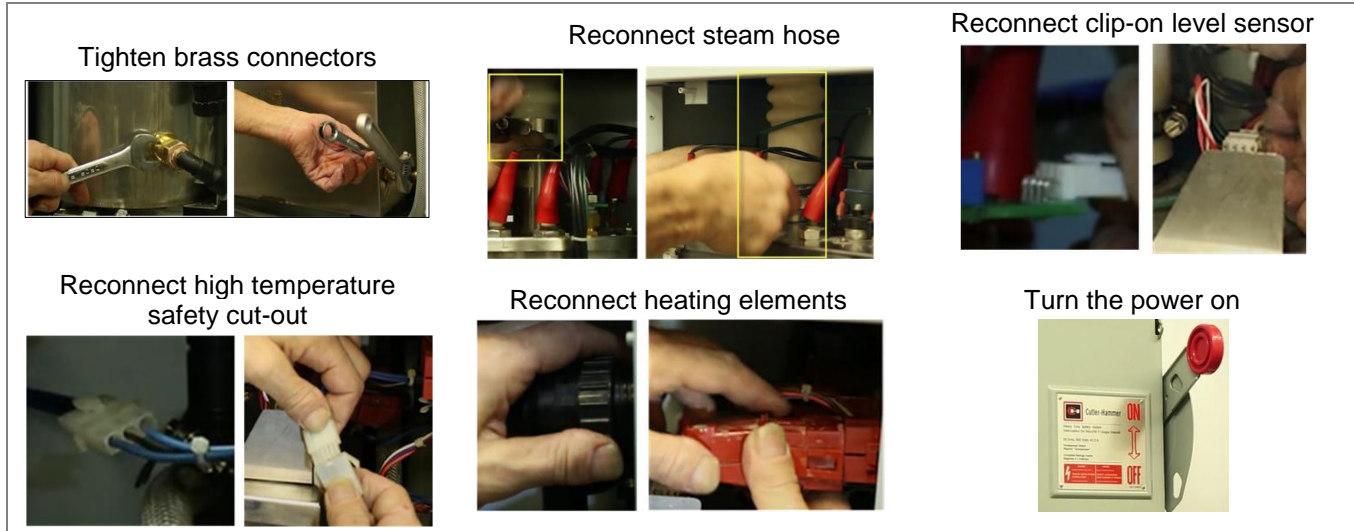

5. Reconnect the high-temperature safety cut-out wire.
6. Reconnect the heating elements.
Turn the power back on at the disconnect switch or the breaker.

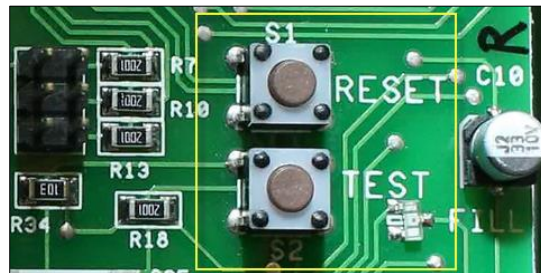

Stage 4 - Restart and reset the humidifier

1. Power up the humidifier.
2. Reset the humidifier by pressing the TEST and RESET buttons on the main PC board.



3. When you press the TEST button, the humidifier goes into the drain mode. The drain LED  illuminates indicating the drain mode. Then press the RESET button.
4. The humidifier now operates in the automatic mode and fills with water as soon as it detects a demand for humidity.
5. To stop the red LED check light from blinking after the servicing, do the following:
 - a. Press the menu  button till the RUNNING HRS display appears.
 - b. Press the  and  buttons simultaneously for 15 seconds or until the hours are zero on the display.
6. Set the drain cycles for every four hours of operation. This is the factory default setting and is recommended for city water.
 - Press the menu  button till the DRAIN HOURS appears on the display.

After the water boils for four hours in the chamber, it is laden with minerals and solutions. This affects the humidity output and the efficiency of the humidifier. So, dilute the boiling water by initiating a drain cycle.



Exploded View and Bill of Material

Exploded View

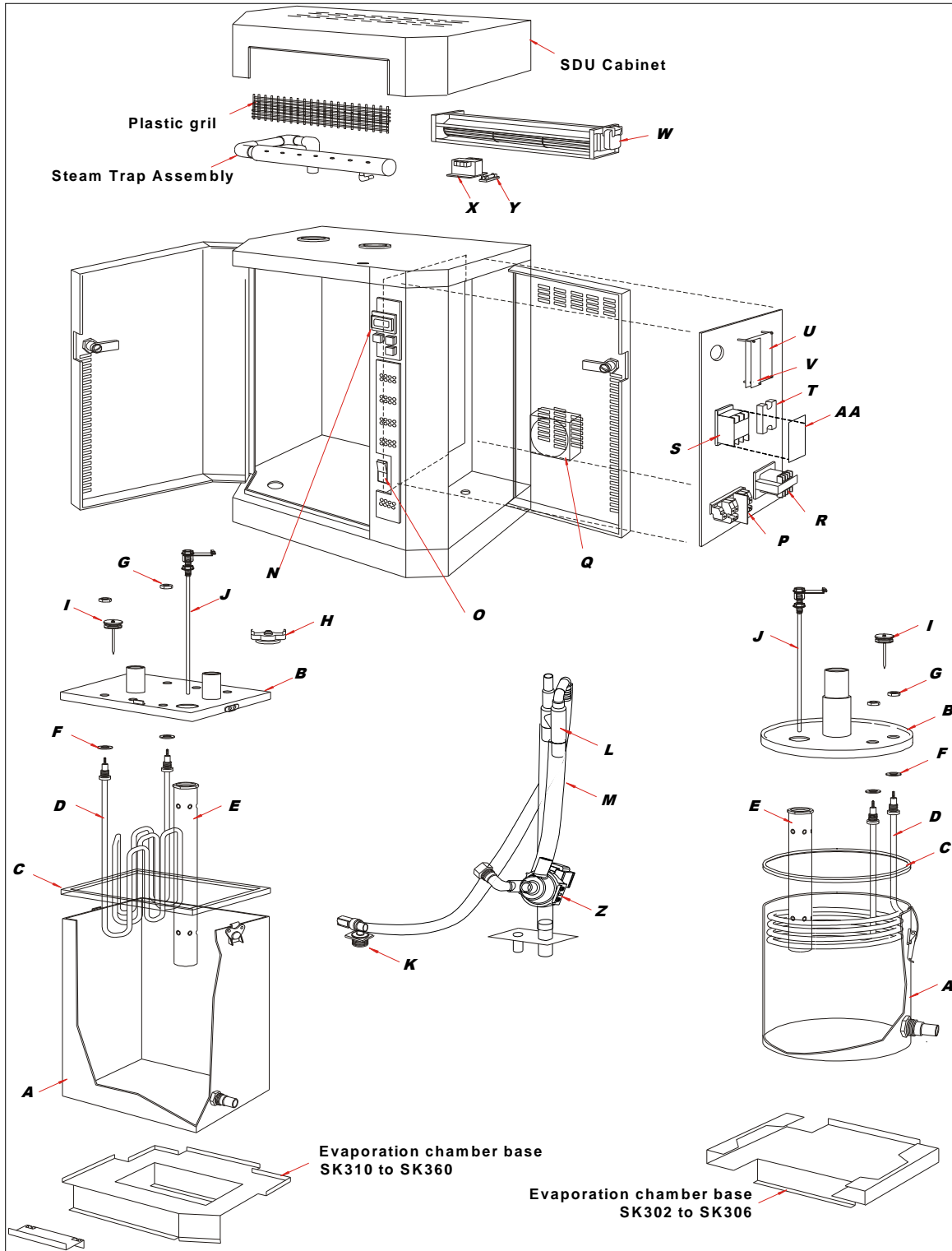

Illustration 43 - Exploded View of Humidifier

Bill of Material

Table 10 - Model Description and Part Numbers

Item	Description	Model	Part number
A	Container of evaporation chamber	SK302 to 306	SW CONTSMA-ASSY
		SK310 to SK330	SW CONTMED-ASSY
		SK320 L, SK340 to SK360	SW CONTLAR-ASSY
B	Cover of evaporation chamber	SK302 to 306 (1 phase)	SP 4018-M
		SK304 to 306 (3 phases)	SP 4019-M
		SK310 & SK314	SP 4183A
		SK316 to SK330	SP 4183B
		SK320 L & SK340	SP 4186
		SK360	SP 4185A
C	Evaporation chamber gasket	SK302 to 306	SP 1008
		SK310 to SK330	SP 1021
		SK320 L, SK340 to SK360	SP 1022
D	Heater element	See Table 11 - Model, Heater Element, Transformer, and Voltage Description	
E	Level sensor chamber	SK302 to 306	SP 4196-M
		SK310/314/316/320/320 L/340	SP 4197-M
		SK330/350/360	SP 4198-M
F	Washer (elements)	SK302 to SK360	SP 1005
G	S/S hex. Jam nut (elements)	SK302 to SK360	SP 2330
H	High temperature switch (klixon)	SK302 to SK360	SP 3035
I	Foam sensor	SK302 to 306	SW FOAMSM-ASSY
		SK310/314/316/320/320 L/340	SW FOAMMED-ASSY
		SK330/350/360	SW FOAMLG-ASSY
J	Water level sensor	SK302 to 306	SW PROBSMR1
		SK310/314/316/320/320 L/340	SW PROBMDR1
		SK330/350/360	SW PROBLARR1
K	Water supply valve	SK302 to SK360	SP 6007
L	Fill and drain trap assembly	SK302 to 306	SW TRAPSMA-P
		SK310 to SK330	SW TRAPMED-P
		SK340 & SK360	SW TRAPLAR-P
M	Silicone tubing ½"	SK302 to SK360	SP 1023A
	Silicone tubing ¾"		SP 1023B
	PCV tubing ½"		SP 1027
N	Alphanumeric display	SK302 to SK360	SW SK300DISPL-ASSY
O	"AUTO/OFF/DRAIN" Rocker switch	SK302 to SK360	SW SKSWITCH-ASSY
P	Terminal block and high voltage connectors	SK302 to SK360	-
Q	Cooling fan	SK302 to SK360	SP 3007
R	Transformer	Refer to Table 11 - Model, Heater Element, Transformer, and Voltage Description	
S	Contactor	Refer to Table 11 - Model, Heater Element, Transformer, and Voltage Description	
T	Solid State Relay	50 A	SP 3102
		90 A	SP 3103
		125 A	SP 3105
U	Main Printed Circuit Board	SK302 to SK360	NW SK300MAIN-TEST
V	Modulating Printed Circuit Board	SK302 to SK360	NW SK300MODULSS
W	SDU fan	SDU I	SW FANSDU1-RET
		SDU II	SW FANSDU2-RET



Item	Description	Model	Part number
		SDU III	SP 3010
X	Transformer	Refer to Table 11 - Model, Heater Element, Transformer, and Voltage Description	
Y	Fuse inside SDU	SDU I and SDU 2	SP 5105
		SDU 3	SP 5106
Z	Drain pump	SK302 to SK360	SP G4101

Table 11 - Model, Heater Element, Transformer, and Voltage Description

Model	Voltage	D Heater element	R Transformer	S Contactor	X SDU Transformer
SK302	120V/1~	SW 5943	SP 3380	SP 3029	-
	240V/1~	SW 5932	SP 3310	SP 3029	SP 3312
	208V/1~	SW 5933	SP 3308	SP 3029	SP 3305
	480V/1~	SW 5934	SP 3321	SP 3029	SP 3329
	600V/1~	SW 5935	SP 3341	SP 3029	SP 3349
SK304	240V/1~	SW 5937	SP 3310	SP 3029	SP 3312
	208V/1~	SW 5940	SP3308	SP 3029	SP 3305
	208V/3~	SW 5924	SP3308	SP 3080	SP 3305
	480V/1~	SW 5941	SP 3321	SP 3029	SP 3329
	480V/3~	SW 5923	SP 3321	SP 3080	SP 3329
	600V/1~	SW 5942	SP 3341	SP 3029	SP 3349
	600V/3~	SW 5925	SP 3341	SP 3080	SP 3349
SK306	240V/1~	SW 5938	SP 3310	SP 3029	SP 3312
	208V/1~	SW 5943	SP3308	SP 3029	SP 3305
	208V/3~	SW 5933	SP3308	SP 3080	SP 3305
	480V/1~	SW 5944	SP 3321	SP 3029	SP 3329
	480V/3~	SW 5934	SP 3321	SP 3080	SP 3329
	600V/1~	SW 5945	SP 3341	SP 3029	SP 3349
	600V/3~	SW 5935	SP 3341	SP 3080	SP 3349
SK310	208V/3~	SW 5959	SP 3308	SP 3100	SP 3305
	480V/3~	SW 5958	SP 3321	SP 3080	SP 3329
	600V/3~	SW 5957	SP 3341	SP 3080	SP 3349
SK314	208V/3~	SW 5946	SP 3308	SP 3084	SP 3305
	480V/3~	SW 5947	SP 3321	SP 3080	SP 3329
	600V/3~	SW 5948	SP 3341	SP 3080	SP 3349
SK316	208V/3~	SW 5960	SP 3308	SP 3084	SP 3351
	600V/3~	SW 5958	SP 3341	SP 3100	SP 3351
SK320	480V/3~	SW 5950	SP 3321	SP 3100	SP 3352
	600V/3~	SW 5951	SP 3341	SP 3100	SP 3353
SK330	480V/3~	SW 5952	SP 3321	SP 3220	SP 3352
	600V/3~	SW 5939	SP 3341	SP 3100	SP 3353
SK320 L	208V/3~	SW 5959	SP 3381	SP 3084 (2x)	-
SK340	208V/3~	*	*	*	-
	480V/3~	SW 5950	SP 3321	SP 3220 (2x)	-
	600V/3~	SW 5951	SP 3341	SP 3220 (2x)	-
SK350	480V/3~	SW 5950 SW 5952	SP 3321	SP 3220 (2x)	-
	600V/3~	SW 5951 SW 5939	SP 3341	SP 3220 (2x)	-
SK360	480V/3~	SW 5952	SP 3321	SP 3220 (2x)	-
	600V/3~	SW 5939	SP 3341	SP 3220 (2x)	-

* Available, please consult factory.

Troubleshooting

Humidifier does not operate (Power Off)

Indicator	Status	Display (blank)
Power	OFF	
Check	OFF	
Fill	OFF	
Steam	OFF	
Drain	OFF	

Cause

- The humidifier is not powered.
- The low voltage fuse is open.
- The high-temperature switch is open.
- Wires harnesses inside the humidifier are not secured properly.

Corrective Action

- Check for the main power supply and fuses.
- Check the transformer and the low voltage fuse.
- Check the high-temperature switch, the wire harnesses and the main PC board.

Humidifier does not operate (Power On)

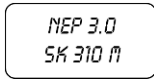
Indicator	Status	Display
Power	ON	
Check	OFF	
Fill	OFF	
Steam	OFF	
Drain	OFF	

Cause

- The Rocker switch is at the OFF position.
- Wire harness from the LED display panel to the main PC board is not secured properly.

Corrective Action

- Press the Rocker switch to the AUTO position.
- Check the white color wire harness.
- Press the RESET button on the main PC board.

Humidifier does not produce steam (No Demand)

Indicator	Status	Display
Power	ON	
Check	OFF	
Fill	OFF	
Steam	OFF	
Drain	OFF	

Cause

- Modulating humidifier: no analog signal.
- On/Off humidifier: no demand from humidistat, or air flow is not detected by air pressure switch or high limit humidistat is open.
- Control wires are not properly secured to the terminal blocks.

Corrective Action

- Verify the setting of the humidistat.
- Check the fan operation.
- Check the operation of the high limit humidistat.
- Verify the connections of the wires to the control terminal blocks.

Humidifier does not produce steam (Safety Open) Modulating Humidifiers only

Indicator	Status	Display
Power	ON	
Check	OFF	
Fill	OFF	
Steam	OFF	
Drain	OFF	

Cause

- Air flow is not detected by air pressure switch, or high limit humidistat is open.
- Control wires are not properly secured to the terminal blocks.

Corrective Action

- Check the fan operation.
- Check the operation of the high limit humidistat.
- Verify the wires to the control terminal blocks #1 & 2.

No water inside the evaporation chamber or Humidifier does not stop draining

Indicator	Status	Display
Power	ON	
Check	ON	
Fill	ON	
Steam	OFF	
Drain	OFF	

Cause

- The humidifier is filling water but has not reached yet or does not reach the high limit of the water level sensor.
- The humidifier is not filling water.

Corrective Action

- Verify if the drain valve is open.
- Check if the shutoff valve on the water supply line is open.
- Verify the operation of the fill valve.
- Check that the fill valve strainer and the external strainer are not blocked.

Humidifier is always on Foam cycle

Indicator	Status	Display
Power	ON	
Check	OFF	
Fill	ON	
Steam	OFF	
Drain	ON	

Cause

- Excessive foaming condition inside the evaporation chamber.
- Foaming sensor is grounded.

Corrective Action

- Verify the quality of the supply water.
- Verify if chemical products were used to clean the evaporation chamber during maintenance. Rinse the chamber properly with water.
- Check the setting of the Drain cycle. Reduce the time between Drain cycles.

Humidifier is operating and the CHECK light is flashing

Indicator	Status	Display
Power	ON	
Check	BLINK	
Fill	OFF	
Steam	ON	
Drain	OFF	

Cause

- The running hours have exceeded the Service hours.

Corrective Action

- Service the evaporation chamber, see Service section.
- Reset the Running hours to cancel the blinking of the CHECK light.

Humidifier is not operating and the CHECK light is ON

Indicator	Status	Display
Power	ON	
Check	ON	
Fill	OFF	
Steam	OFF	
Drain	OFF	

Cause

- The electronic temperature sensor inside the water level sensor had sensed abnormal temperature.
- The quick connector to the water level sensor was removed while the humidifier was operating.
- The brown wire connected to the top left corner of the main PC board is not properly secured.

Corrective Action

- Verify if the humidifier was operating below the standard water level and then replace the water level sensor, item J.
- If the connector is removed while power is still ON, press the TEST button on the main PC board until the Drain light is turned ON. Then press RESET once.
- Verify the connection of the brown wire to the main PC board.

Humidifier is not operating and the CHECK light is ON

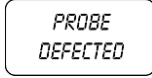
Indicator	Status	Display
Power	ON	
Check	ON	
Fill	OFF	
Steam	OFF	
Drain	OFF	

Cause

- The water level sensor is damaged.

Corrective Action

- Replace the water level sensor, item J.

Humidifier does not drain and the CHECK light is ON

Indicator	Status	Display
Power	ON	
Check	ON	
Fill	OFF	
Steam	OFF	
Drain	OFF	

Cause

- During a Drain or Foaming cycle, the water level sensor has sensed that the water level has not decreased.

Corrective Action

- Verify that the drain pump, the fill and drain water pipe connection, the water level sensor chamber are not obstructed.

Humidifier does not operate and display is blank

Indicator	Status	Display (blank)
Power	ON	
Check	OFF	
Fill	OFF	
Steam	OFF	
Drain	OFF	

Cause

The following components can be the cause of this problem: water level sensor (item J), main PC board (item U), modulating PC board (item V) or the LCD (item N).

Corrective Action

Call factory for troubleshooting instructions.



Humidifier is producing steam and display is blank

Indicator	Status	Display (blank)
Power	ON	
Check	OFF	
Fill	OFF	
Steam	ON	
Drain	OFF	

Cause

- The potentiometer contrast is set at the lowest setting.
- The display ribbon cable is not connected properly.
- The LCD is defective.

Corrective Action

- Adjust the contrast of the display.
- Verify that the connections of the ribbon cable are properly secured and are on the right side (red line on cable).
- Replace the LCD, item N.



neptronic[®]

400 Lebeau blvd, Montreal, Qc, H4N 1R6, Canada

www.neptronic.com

Toll-free in North America: 1-800-361-2308

Tel.: (514) 333-1433

Fax: (514) 333-3163

Customer service fax: (514) 333-1091

Monday to Friday: 8:00am to 5:00pm (Eastern time)