

Electric Duct Heaters Brochure

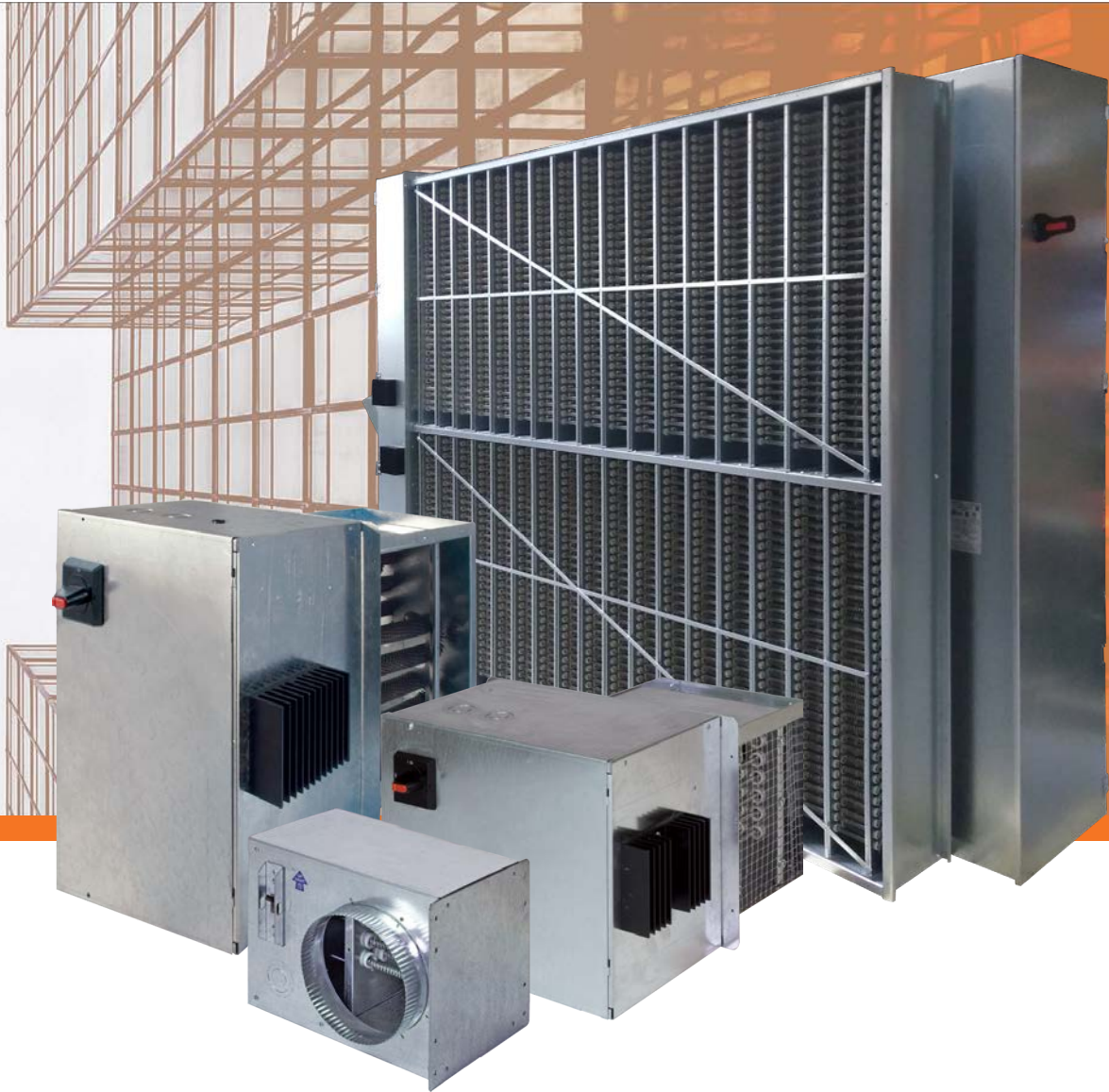

neptronic[®]

ELECTRIC DUCT HEATERS

The Neptronic electric heater is manufactured using the most advanced technologies available. Total automation from design to production using integrated CAD/CAM systems not only assures maximum efficiency, but also prevents errors in plans and specification data. The most advanced CNC technology for sheet metal fabrication is used in manufacturing the heaters. All these factors are key to offering standard features that our competitors offer only as options, and allows us to respond in record time to your needs and to the most demanding specifications.

Advantages

- HECB Networkable Electric Duct Heaters
- Patented EAS Electronic Air Flow Sensors (US 7,012,223)
- Unique interactive software
- Up to 40kW per sq. ft. (CSA) and 24 kW per sq. ft. (UL)
- Modulating, ON/OFF or staging
- Standard from 0.5 to 1000 kW, larger loads available

Typical Applications

■ HVAC systems
VAV boxes

■ Fan coil units

■ Load banks
testing

■ Make-up air /
Air handlers

■ Process air
heaters

■ Transport /
Railcar / Marine



Typical Installation

■ Slip-in

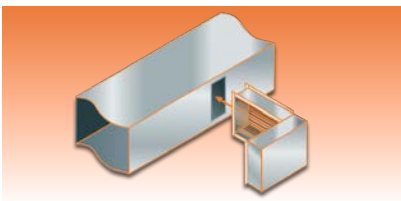

The slip-in type electric heaters are designed so that the entire frame can be inserted into the duct. Using a slip-in heater permits the installation of the entire ventilation duct system before the heaters become available.

■ Flanged

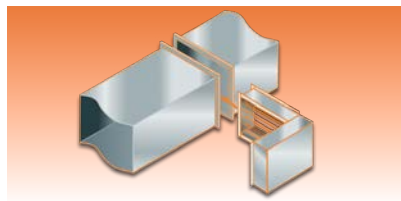

Flanged heaters are designed so that the heater is an integral part of the duct work. The heater frame is attached to matching duct flanges. Standard 1" (25.4mm) flanges on the heater frame are used to attach it to the duct.

■ Round Collar

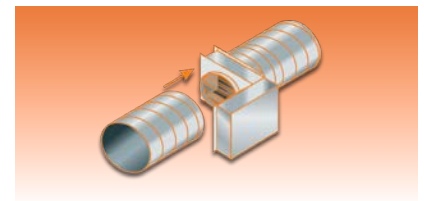

Round collar electric heaters are available for installation on round duct systems. They are provided with one male and one female adapter for ease of installation.

System Overview

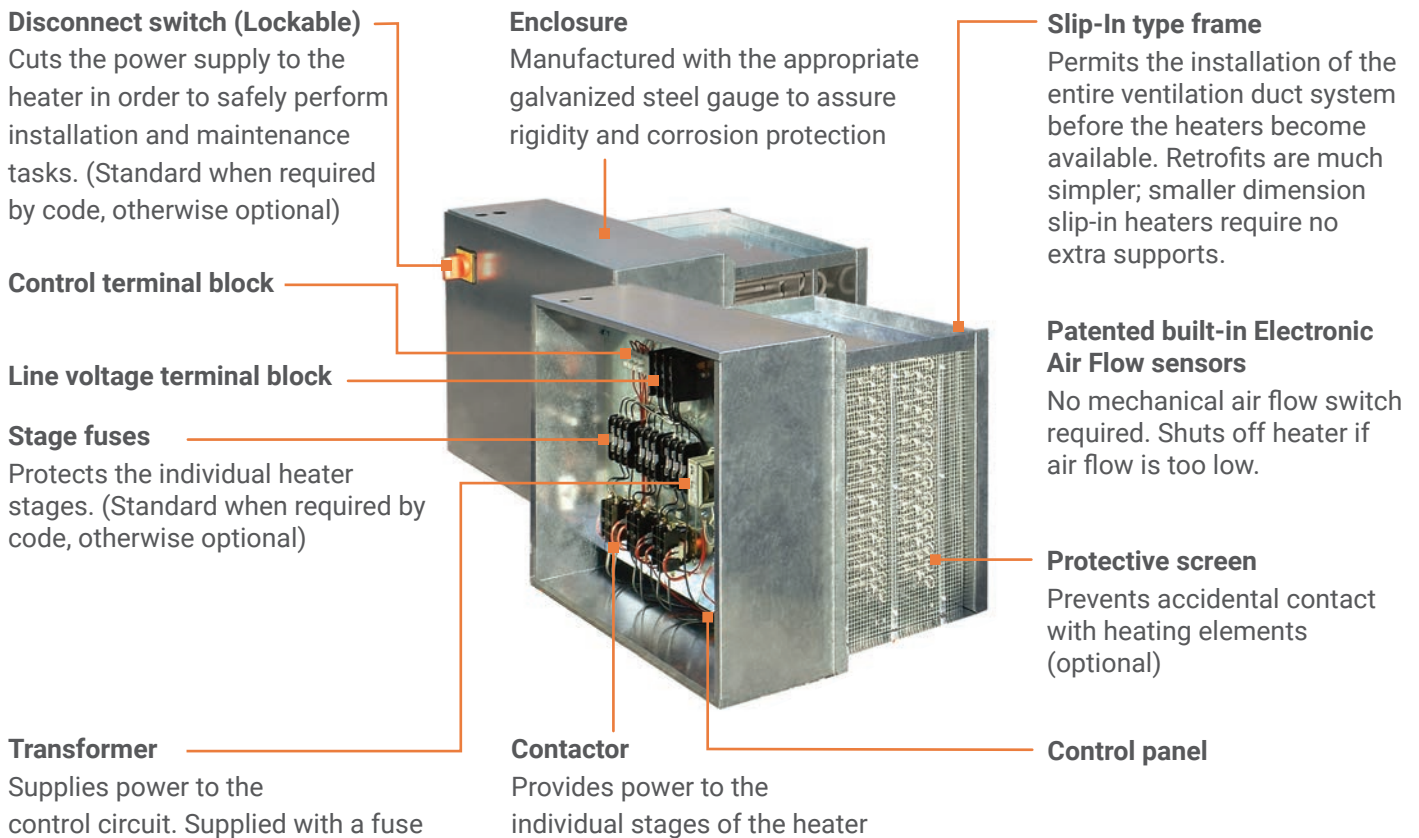

Variety of Heating Elements

Open Coil



- Grade C NiCr60 (60% Nickel and 16% Chrome)
- Grade A NiCr80 (80% Nickel and 20% Chrome)

Advantages

- Excellent heat dissipation
- Minimal pressure drop
- Fast response time
- More kilowatts per sq.ft.
- Quick delivery

Tubular



- Incoloy 800 (Nickel alloy)
- Stainless steel 304 or 316
- U or W shapes depending on heater dimension

Advantages

- Less sensitive to humidity and dust
- Suited for demanding environments
- Excellent mechanical resistance
- Heating element not in direct contact with air

Finned Tubular



- Incoloy 800 (Nickel alloy)
- Stainless steel 304 or 316
- U or W shapes depending on heater dimension. Stainless steel fins are available as an option to allow for more efficient heat dissipation.

Advantages

- Good heat dissipation
- Less sensitive to humidity and dust
- Suited for demanding environments
- Excellent mechanical resistance
- Heating element not in direct contact with air

Mounting

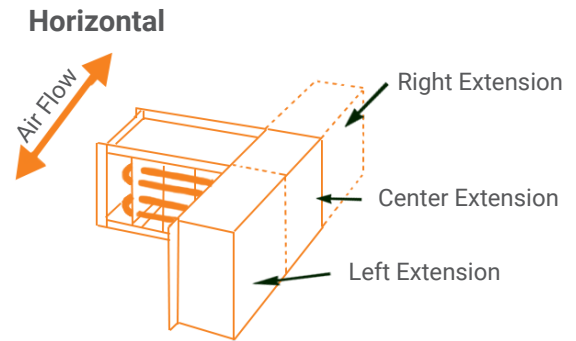
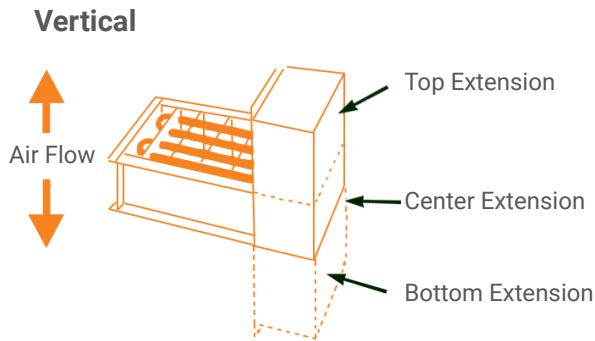

Panel Options

Bottom Control Panel

A bottom control panel can be supplied, when required for easy installation and maintenance. This option is available for all heaters (Slip-in, flanged and round collar) of small dimensions.

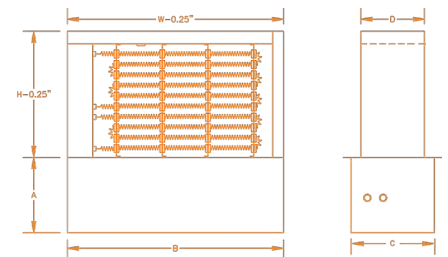

Insulated Control Panel

An insulated control panel is recommended for high duct temperatures. Insulation material, 1" (25.4mm) thick is installed between the panel and the hot area to prevent condensation on electrical components.

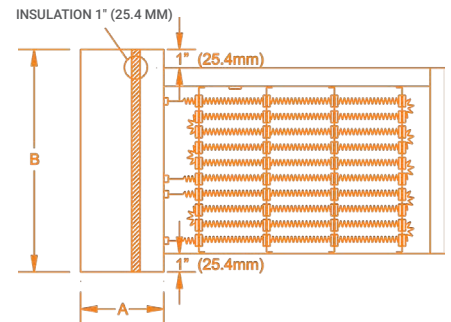

Remote Control Panel

In certain cases it may be more convenient to install the control panel remotely from the heater or in a separate room. A remote control panel is available as an option.

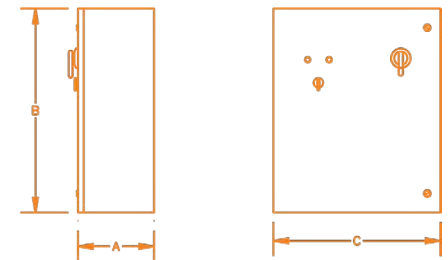

Zero Clearance Construction

All Neptronic heaters are designed and approved for zero clearance to combustible material. Zero clearance construction means that there is no restriction on the distance between combustible materials and the section of the duct housing of the heater, or the heater itself. The control panel must be accessible for servicing.

Enclosure Types

Neptronic heaters come with enclosure types Nema 1 (Standard), Nema 12 (Dust proof), Nema 4 and Nema 4x (Outdoor applications).

Special Heaters

- Process Heaters for applications requiring a high discharge temperature up to 1200°F with proven standards
- Heaters to fit in air handling and make-up air units
- Specially designed for large kW and dimensions

HECB Networkable Controller



ASHRAE BACnet™

Modbus



BENEFITS

Save Energy

- Embedded and configurable energy conservation strategies
- Automatic or dynamic load shedding
- Limit electric heater consumption based on multiple variables
- Provides real-time temperature measures and power consumption data

Save Time

- View heater status and alarms remotely via network or thermostat
- Remote monitoring (status, alarms, diagnostics, and trending)
- Wall-mount remote user interface (view temperature, setpoint, heater status and alarms)

Integrate

- Integrate with BMS and intelligent buildings via BACnet MS/TP or Modbus
- Multiple BACnet/Modbus points to propel you towards the Internet of Things (IoT)
- Ensure better management of energy consumption for the future

Standard Features

- Accepts any industry standard input signal
- Quick and simple input signal selection via DIP switches
- Modulating, on/off, and/or up to 10 stages
- Real-time feedback output of heater capacity
- Automatic PID
- Remote feedback with TDU LCD thermostat (eliminates the use of expensive staged thermostats)
- Zero voltage crossing SSR
- Patented EAS Electronic Air Flow Sensors (US 7,012,223)

Network Communication

- BACnet MS/TP or Modbus RTU (selectable via DIP switch)
- Select MAC address via DIP switch or via network

BACnet MS/TP

- MS/TP @9600, 19200, 38400 or 76800 bps
- BACnet scheduler (up to 6 events)
- Firmware upgradeable via network
- COV (change of value)
- Copy and broadcast configuration to other HECB controllers via menu or network
- Automatic baud rate detection
- Automatic device instance configuration

Modbus RTU

- Modbus RTU @9600, 19200, 38400 or 57600 bps
- RTU Slave, 8 bits (configurable parity and stop bits)
- Connects to any Modbus RTU master

Heater Selection Software

Whether you are an engineer or a contractor, our software allows you to select the required electric heater by entering basic data (duct dimensions, airflow, power, voltage, number of stages, control signals, etc.) from a user friendly window. The selection software then calculates the optimum specifications for each electric heater. The comprehensive heater specifications, as well as the approval list, may be edited or inserted in the project file.

Interactive Online Software

Linked to an automated manufacturing process. Neptronic's web-based selection software allows you to easily select the required electric heater by entering the basic data.

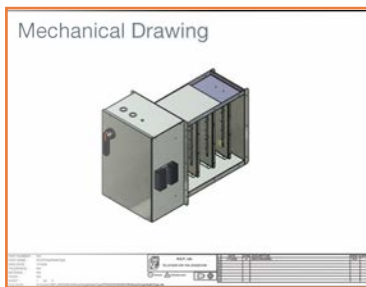

Specifications entered are transformed in parametric design



Electric heater is produced by automated machines



Heater is ready in record time produced with minimum human inputs.

- Multiple components & options available to design your heaters
- Allows you to make as many changes as you want in your selection
- Retrieve immediately your heater's schedule and specification
- Creates mechanical and electrical drawings
- Generates approval specification sheets
- Saves your project history in a database
- Access to part list
- Access to current lead times

Thermostats & Temperature Sensors for Electric Heaters

Room Controller thermostat



TR024-EXT1

- For modulating, ON-OFF, staging or pulsed heater
- Backlit LCD display
- 2 heat / cool analog outputs (0-10VDC)
- 4 TRIAC outputs (for ON-OFF, pulse or floating signal)
- Selectable internal/external temperature sensor
- Selectable proportional control band
- Fahrenheit or Celsius scale selectable

Room Controller thermostat



TR05404

- For modulating, ON-OFF, staging or pulsed heater
- Backlit LCD display
- 2 heat / 2 cool analog outputs (0-10VDC)
- 1 TPM (time proportional modulation) output (0 or 22VDC)
- Selectable internal/external temperature sensor
- Selectable proportional control band
- Fahrenheit or Celsius scale selectable

Wall thermostat



STS3 / ITO3

- Modulating, ON-OFF or staging heater
- STS3 with sensor 3.3 KΩ or available in 10 KΩ
- ITO3 wall thermostat must be used with external duct or wall sensor
- Fahrenheit or Celsius scale selectable

Room temperature sensor



STR1

- Wall sensor for remote temperature reading
- Sensor 3.3 KΩ or 10 KΩ available

Duct temperature sensor



STC8

- Duct sensor for remote temperature reading
- Sensor 10 KΩ and 3.3 KΩ
- High accuracy, fast thermal response
- Epoxy encapsulated sensor
- High stability

Wall temperature sensor



TMA54

- Features a fully configurable Proportional-Integral-Derivative (PID)
- 2 heat / cool analog outputs (0-10VDC)
- Selectable internal/external temperature sensor
- Fahrenheit or Celsius scale selectable

MANUFACTURER OF



HVAC CONTROLS



ELECTRIC ACTUATORS



ACTUATED VALVES



HUMIDIFIERS



ELECTRIC HEATERS



neptronic.com