



**Feature:**

- Mounts easy on round & square shaft (with option –8).
- External clutch for manual adjustments.
- Maintenance free.
- Position indicator.
- Fail safe by *Enerdrive System*<sup>1</sup> (on model 60, 65 & 80).
- Auxiliary switches (on model 20 & 80).

**ST000S**  
**ST005S**  
**ST020S**  
**ST060S**  
**ST065S**  
**ST080S**

Technical Data	ST000S	ST005S	ST020S	ST060S	ST065S	ST080S
Auxiliary switches	No	No	Yes (2)	No	No	Yes (2)
Feedback	No	Yes	No	No	Yes	No
Fail safe - <i>Enerdrive</i>	No			Yes		
Power consumption	8 VA			20VA Max, 8VA		
Control signal	3 wire / 2 position, 3 wire / 3 point floating			2 wire / 2 position, 4 wire / 3 point floating		
Power supply	22 to 26 VAC or 28 to 32 VDC					
Running time through 90°	90 - 110 sec. (Fail-safe 20-35 sec)					
Torque	70 in.lb. [8 Nm] at rated voltage					
Electrical connection	18 AWG [0.8 mm <sup>2</sup> ] minimum					
Inlet bushing	2 inlet bushing of 5/8 in [15.9 mm] & 7/8 in [22.2 mm]					
Angle of rotation	0 to 90 degrees, mechanically adjustable (factory set with 90° stroke)					
Direction of rotation	Reversible, Clockwise (CW) or Counterclockwise (CCW) (factory set with CW direction)					
Ambient temperature	-22°F to +122°F [-30°C to +50°C]					
Storage temperature	-22°F to +122°F [-30°C to +50°C]					
Relative Humidity	5 to 95 % non condensing.					
Ingress protection	IP22 equivalent to Nema type 2, IP54 equivalent to Nema type 3R if water tight inlet bushings (not supplied NEP617) are installed					
Weight	3 lbs. [1.4 kg]					

**Warning: Do not press the clutch when actuator is powered**

**Dimensions**

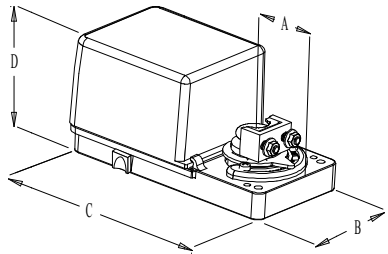

Dimension	Inches	Metric (mm)
A	1.50	38.1
B	3.26	82.8
C	6.60	167.5
D	3.01	76.4

**Caution**

We strongly recommend that all Neptronic® products be wired to a separate transformer and that transformer shall service only Neptronic® products. This precaution will prevent interference with, and/or possible damage to incompatible equipment.  
 When multiple actuators are wired on a single transformer, polarity must be observed. Long wiring runs create voltage drop which may affect the actuator performance.

<sup>1</sup> Enerdrive System U.S.A. Patent #5,278,454



**Mechanical installation**

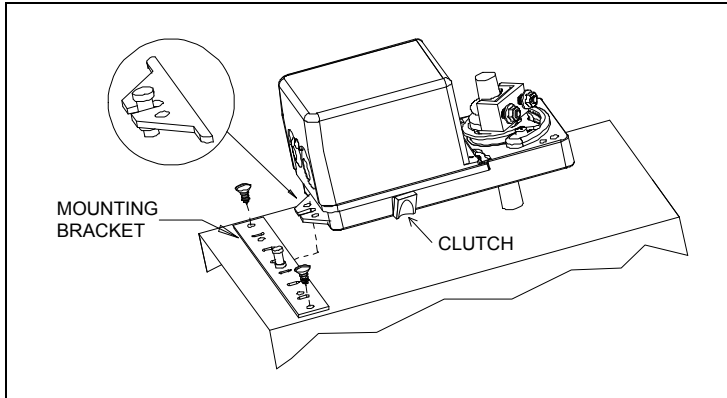

1. Manually close the damper blades and positioned the actuator at 0° or 90°.
2. Slide the actuator onto the shaft.
3. Tighten the nuts on the “U” bolt to the shaft with a 8mm wrench to a torque of 60 in.lb. [6,7 Nm].
4. Slide the mounting bracket under the actuator. Ensure free movement of the slot at the base of the actuator. The bracket pin must be placed in the mid distance of the slot.
5. Fix the bracket to the ductwork with #8 self-tapping screws.

**Wiring Diagrams**

Models ST000S, 005S, 020S	Models ST060S, 065S, 080S
<p><b>3 wire / 2 position (ON-OFF)</b></p>	<p><b>2 wire / 2 position (ON-OFF)</b></p>
<p><b>3 wire / 3 point floating</b></p>	<p><b>4 wire / 3 point floating</b></p>

**PC Board**

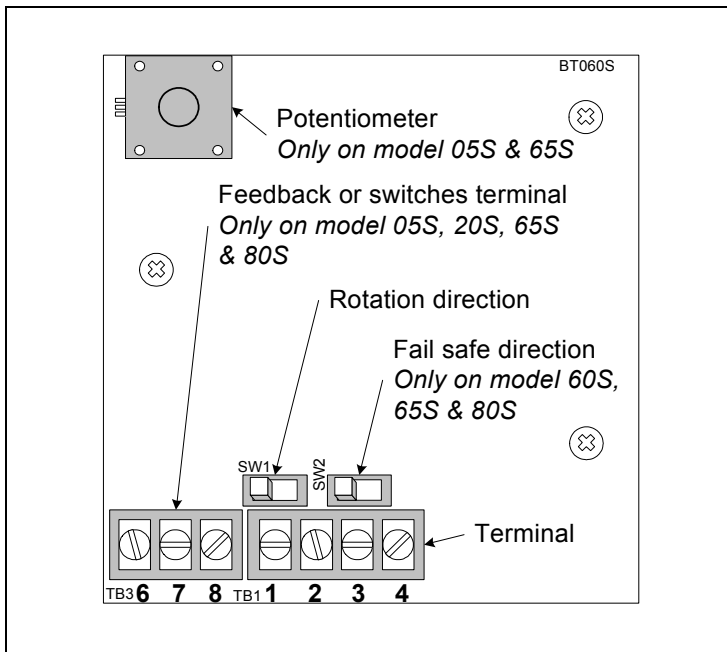

**Dip switch settings**

**Rotation direction (SW1)**

CW (0 to 90°)

CCW (90 to 0°)

---

**Fail safe direction (SW2)**

Fail safe return at 0°

Fail safe return at 90°

**Stroke adjustment**

To adjust the stroke, move the adjustment screws at the desired position.