



neptronic®

SKH4 High-Pressure Atomizer



Installation Instructions and User Manual

Read and save this manual



Intertek
4011008

Foreword

Neptronic Company Overview

Founded in 1976, Neptronic is a private corporation that designs, manufactures and distributes products for the HVAC industry. Our product line includes intelligent controllers, electronic actuators, actuated valves, humidifiers and electric heaters.

Our products are designed and manufactured by over 250 dedicated employees in our 7,500 m² (80,000 ft²) state-of-the-art facility located in Montreal, Canada. Our entire manufacturing chain is under one roof from software and hardware development to SMT circuit board assembly, to sheet metal fabrication, to product testing ensuring that our products are engineered to last using a vertical integration model.

We currently hold several national and international patents, and with our continued commitment to research and development, we provide innovative products and technologies for the ever-evolving challenges of the HVAC industry. Exporting over 75% of our sales, we have an exclusive distribution network around the globe that provides comprehensive solutions to our worldwide customers.

About the Manual

These installation and operation instructions have been developed to facilitate the installation of the SKH4 High-Pressure Atomizer humidifier.

- The strict application of these instructions ensures conformity of your installation and operation as per the manufacturer's recommendations.
- The application of these instructions is one of the conditions for the application of the warranty.
- The application of these instructions does not ensure, at any time, conformity to procedures, regulation or local codes, regarding electric connections and installation to local water supply.

This product has been declared to conform to the applicable Canadian and American safety standards and directives and bear the ETL (c) & (us) mark. The Certificate of Conformity for ETL is available, upon request with the manufacturer.

Copyright Information

Copyright ©2023 by Neptronic.

All rights reserved. This document cannot be reproduced wholly or partially by any means, whether electronic, mechanical, photocopy, recording or other, without prior written authorization of Neptronic.

Health and Safety Instructions

General

This manual has been written to ensure correct, safe and sustainable operation of the SKH4 High-Pressure Atomiser and is intended for use by engineers and technical personnel trained by or their official agents. This manual must be read thoroughly before specifying, designing, installing or operating a SKH4 High-Pressure Atomizer. Please retain for reference and contact Neptronic should you have any questions.



The triangular symbol with the word **WARNING**: is used to designate danger of severe or lethal consequence.



The circular symbol with the word **CAUTION**: is used to designate danger of injury, or to warn of the hazardous operating condition, or other relevant information.

Electrical Warning Message



WARNING:

Risk of electric shock. Do not access. Disconnect SKH4 High-Pressure Atomizer before opening the electrical access door.

All work concerned with electrical installation **MUST** only be performed by skilled and qualified technical personnel (such as an electrician or a technician with appropriate training). The customer is always responsible for ensuring the suitability of the technical personnel.

Please observe the local regulations concerning the provision of electrical installations.

Health & Safety

Installation, maintenance, repair work or de-commissioning should only be carried out by appropriately qualified technical personnel. Any risks or hazards relating to the system, including during installation and maintenance, should be identified by a qualified Health & Safety representative who shall be responsible for introducing effective control measures, as necessary. The customer is responsible for ensuring that the installation of the equipment complies with all local regulations.



CAUTION: Maintenance personnel must be trained by Neptronic or their official agent, and it is the customer's responsibility to ensure their suitability. Failure to use qualified personnel may lead to a hazardous operating condition.



WARNING: Danger of Electrocution! Danger of contact with live parts when the unit is open. Always isolate all water and electrical supplies to the system before commencing any maintenance or repair. Isolate power and water immediately if there are any signs of water leaking from the unit.

Hygiene

IMPORTANT:

Refer to local Health and Safety regulation and codes on the control of Legionellosis in water systems. In the absence of such, ASHREA guideline 12-2023 does provide recommendations. If not adequately monitored and maintained, water systems can support the growth of microorganisms including the bacterium that causes Legionnaires' disease.

The SKH4 has been designed to reduce the potential risk of legionellosis growth. Users also share the responsibility for reducing the risk of legionellosis; users are required to:

- Conduct a risk assessment of the complete water system.
- Implement proper control of the water system.
- Connect the SKH4 to a clean water supply main or higher quality water (such as RO).
- Avoid stagnant water.
- Avoid turning off the system without properly draining all conduit. Automatic drains are scheduled in the unit to avoid the stagnant water.
- Avoid water temperatures that increase the risk of Legionella growth. (77°F to 113°F, 25°C to 45°C)
- Clean and disinfect the system regularly, at least once a year.



WARNING: Risk of Legionnaires' disease, which can be fatal. Install and operate the SKH4 High-Pressure Atomizer as per the instructions given in this Installation Instructions and User Manual.



WARNING: If the SKH4 High-Pressure Atomizer is turned off for prolonged periods (more than 24 hours), ensure that any piping supplying the unit is drained, unless they supply other systems which ensure a regular renewal of water in the system. Failure to do so may result in stagnation of the water and contamination that might cause Legionnaires' disease, which can be fatal.

It is the responsibility of the person on whom the statutory responsibility falls to determine all control and preventative measures outlined in this manual.

Correct Use

Neptronic systems and products are designed only for humidification and cooling use. Any other application is not considered appropriate for the intended purpose. The manufacturer cannot be made liable for any damage resulting from incorrect use.

Important Start-Up Information

Before turning on and operating the SKH4 High-Pressure Atomizer:

- Read all instructions and installation procedures outlined in this manual. Ensure that the operation of the system is properly understood before commencing the start-up procedure.
- Ensure that all wiring is properly installed and that all connections have been made correctly, including the network communication cable between the pump station and the RVP(s).
- Verify all piping before starting up the system. As each zone may have a different capacity and the system has been configured as such, connecting the wrong RVP output to a zone may lead to erratic operation.

General Warranty

This product is subject to the terms and conditions described at www.neptronic.com/sales-conditions.aspx.

Handling and Packaging

Lifting or Handling **MUST** be carried out by trained and qualified personnel. Ensure that the lifting operation has been properly planned, assessed for risk and that the equipment is checked by a qualified Health & Safety representative, and effective control measures are in place.



It is the customer's responsibility to ensure that the operators are trained in handling heavy goods and to enforce the relevant lifting regulations.

The SKH4 High-Pressure Atomizer **MUST** always be handled and lifted with care and should remain in its original packaging for as long as possible before installation.

The SKH4 High-Pressure Atomizer package may be carried using a forklift from the underside. Caution should be exercised to ensure balanced load before lifting.

Inspection

Upon receipt, and once packaging material is removed, carry out an inspection to ensure that no damage occurred during transit. Report any damage immediately to your Neptronic representative.

Unpacking

The SKH4 pump station is delivered in a crate. All other optional products, such as the distributors or the remote valve panel are delivered separately in carton.



Table of Contents

- Handling and Packaging iv
- Overview..... 7
 - Benefits.....7
 - Features7
- SKH4 System 8
 - Principle of Operation8
- SKH4 Pump Station..... 9
 - Visual Overview9
 - Pump Unit Nomenclature 11
 - Capacities and Power Consumption of the Pump Unit (Brass) 12
 - Capacities and Power Consumption of the Pump Unit (SS)..... 13
 - Dimensions and Weight 14
- Fan-Assisted Distributors..... 15
 - Fan-Assisted Distributors Nomenclature..... 15
 - Capacities and Power of the Fan-Assisted Distributors 15
 - Fan-Assisted Distributors Dimensions and Weight 16
- In-Duct Distribution Rack 17
- Basic Installation Overview..... 18
- Pump Unit Installation..... 19
 - Step 1 – SKH4 Pump Station Installation..... 19
- General Recommendations..... 19
 - Step 2 – Water Connections for the SKH4 Pump Station 21
 - Step 3 – Power Supply Connections..... 23
- Power Supply Connections on SKH4 Pump Station 23
- Power Supply Knockout Holes Location on SKH4 Pump Station 24
 - Step 4 – Electrical Control Connections..... 25
- Safety Contact Connections for Pump Unit..... 25
- Safety Contact Connections Single Zone Without TRUB 25
- Safety Contact Connections per Zone from TRUB 25
- Network Communication 26
 - Step 5 – Pump Controller Installation and Configuration 27
- Idle Screen 28
 - Menu Access 28
- Configuration parameters 29
- Control function 29
- Control Profile Selection 29
- Single Zone Operation 29
- Multi-Zones Operation 30
- Menu - General [Level 1 - No password required] 31
- Menu - User Settings [Level 2 - Requires level 2 (or higher) password in order to access] 34
- Menu - Service [Level 3 - Requires level 3 (or higher) password in order to access]..... 36
- Menu - Installation [Level 4 - Requires level 4 (or higher) password in order to access] 37
- Menu - Integration [Level 5 - Requires level 5 password in order to access] 41
 - List of Alarms and Warnings 44
- Distribution Installation..... 45
- Spraying in Space (Standard) 45
- Spraying in Space with Fan-Assisted Distributors 47
- Spraying in Duct 50

Optional – Remote Valve Panel (RVP) 51
 RVP Dimensions 51
 Location 52
 Positioning 52
 Wall Mounting..... 52
 Start-Up Procedure..... 53
 Initial Verification 53
 Diagnostic mode..... 54
 Servicing and Maintenance 55
 Preventative Maintenance 55
 Preventive Maintenance (continued)..... 56
 Nozzle Cleaning 57
 De-scaling the Droplet Separator 58

Overview

The SKH4 High-Pressure Atomizer uses water through a high-pressure system to produce a fine mist with a droplet size of less than 20µm. The ambient air absorbs the fine mist, and the SKH4 adapts to seasonal changes to provide direct evaporative cooling in summer and humidification in winter. Additionally, the SKH4 provides BACnet MS/TP communication, multi-zone operation (up to 4 zones) and remote connection to the entire system from any zone.

Benefits

- Very low energy consumption
- Free cooling (up to 21.5°F [12°C])
- Hygienic operation
- Environmentally friendly
- Low pressure drop in ventilation conduit

Features

The following are the features of the SKH4 High-Pressure Atomizer:

- High pressure pump with recirculation valve integrated.
- Full stainless steel distribution valves and fittings.
- Corrosion resistant distribution network made of stainless steel pipe or nylon tube.
- BACnet communication (optional).
- User-friendly, menu-driven LCD (128 x 64).
- Real-time clock and SD card or USB key for schedule, trending, and history log.
- Firmware upgrade using an SD card or USB key.

SKH4 System

Principle of Operation

The SKH4 High-Pressure Atomizer is a system for humidifying and cooling with a fine mist of water droplets. The pump unit pressurizes the high-quality water until it reaches a pressure of 1000psi (69bar), then distributes it throughout a network of stainless steel pipes or nylon flexible conduits, which then distributes the pressurized water as a fine mist. These water particles measure less than 20µm. This mist is then easily absorbed into the air, providing humidification, and cooling, through the adiabatic evaporation process.

The SKH4 Pump Unit is equipped with a pump and a motor that can use an optional VFD in order to control the pump speed. The regulation of the outlet pressure is assured mechanically by the pump, in order to maintain a consistent and reliable outlet pressure, regardless of the configuration of stages open.

The unit is equipped with two analog manometers place in the front, one for the low pressure and one for the high-pressure outlet. There are also digital manometers so that the controller can monitor those pressures. The low pressure controls the input of water to the pump in order to protect the pump unit from running dry. The high-pressure sensor monitors the output of the pump, in order to assure consistent mist generation and detect leakage.

In case of unexpected shutdown and failure of valve that could create a water hammer coming back to the pump, a pressure relief is placed in the recirculation loop. The relief valve prevents damage to the inlet of the pump and the low-pressure components.

The distribution of high-pressure water is assured in the pump unit, or optionally from a remote valve panel, with an array of configurable valves. Each pair of valves (one for the input and one for the drain) is assigned at the installation to a capacity in mass per hour and to a control signal. The unit is able to receive up to 4 control signals in order to cover 4 different zones, which can also be split up into 6 stages in total.

The control signals are displayed either by using a thermostat in each zone that is connected to the unit or by connecting through a BMS with a demand directly to the unit. The BMS can be connected via BACnet or Modbus protocols.

The distribution of mist is accomplished by using anti-drip stainless steel nozzles which are designed to create a cone of mist to shoot the water droplets directly into the air. The nozzles are either installed directly in the space or in an AHU.

In-space distribution requires installing distribution piping (stainless steel or nylon flexible conduit), with a fitting for each nozzle. Clearances are important between nozzles and any obstacle in the area, such as trusses, columns and/or tall equipment. See the hydraulic and distribution design guide for more details.

In-space distribution can be facilitated with optional fan-assisted distributors. Those distributors allow reduced absorption distances and improve the coverage of the distribution network.

SKH4 Pump Station

Visual Overview

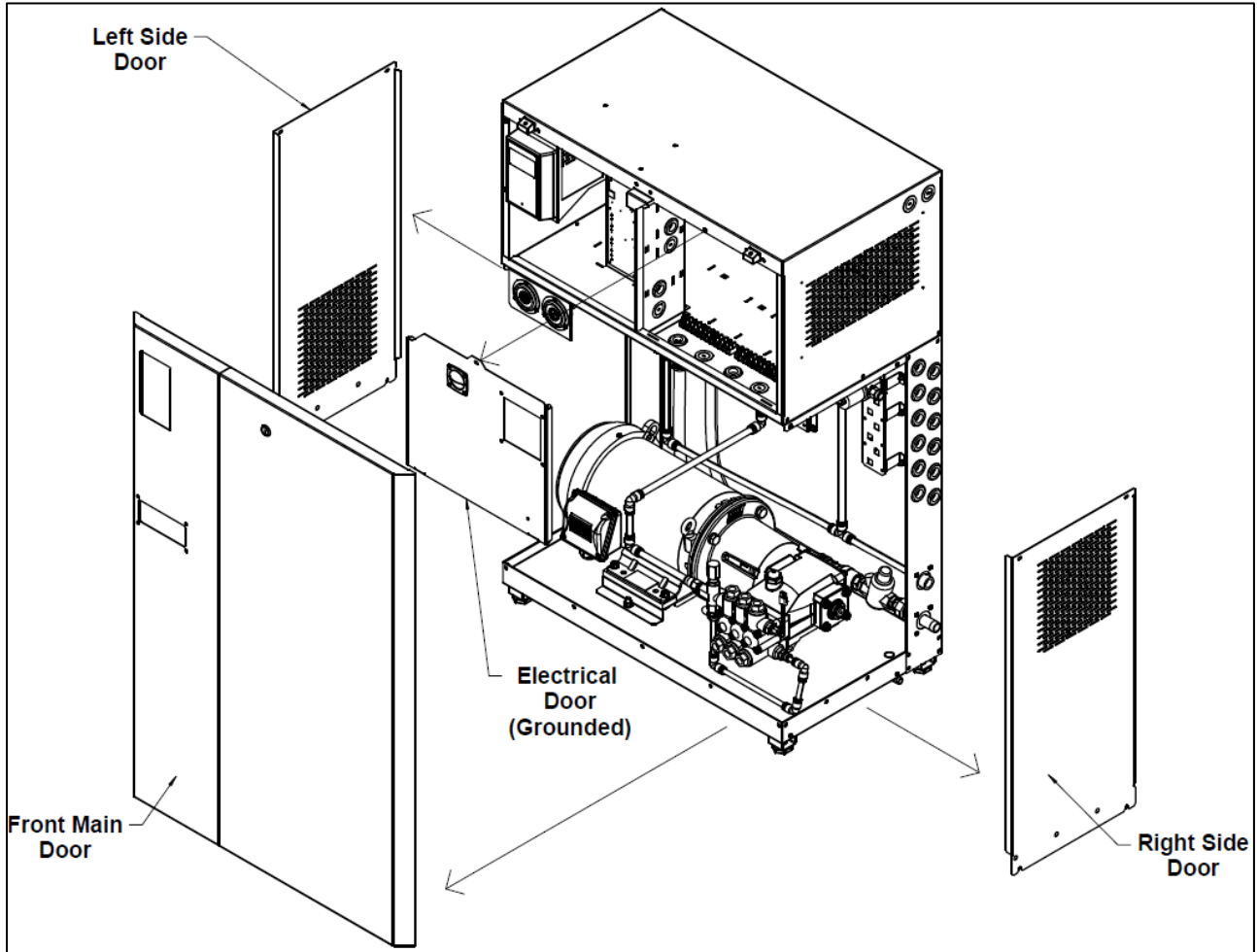

Illustration 1 - SKH4 Enclosure

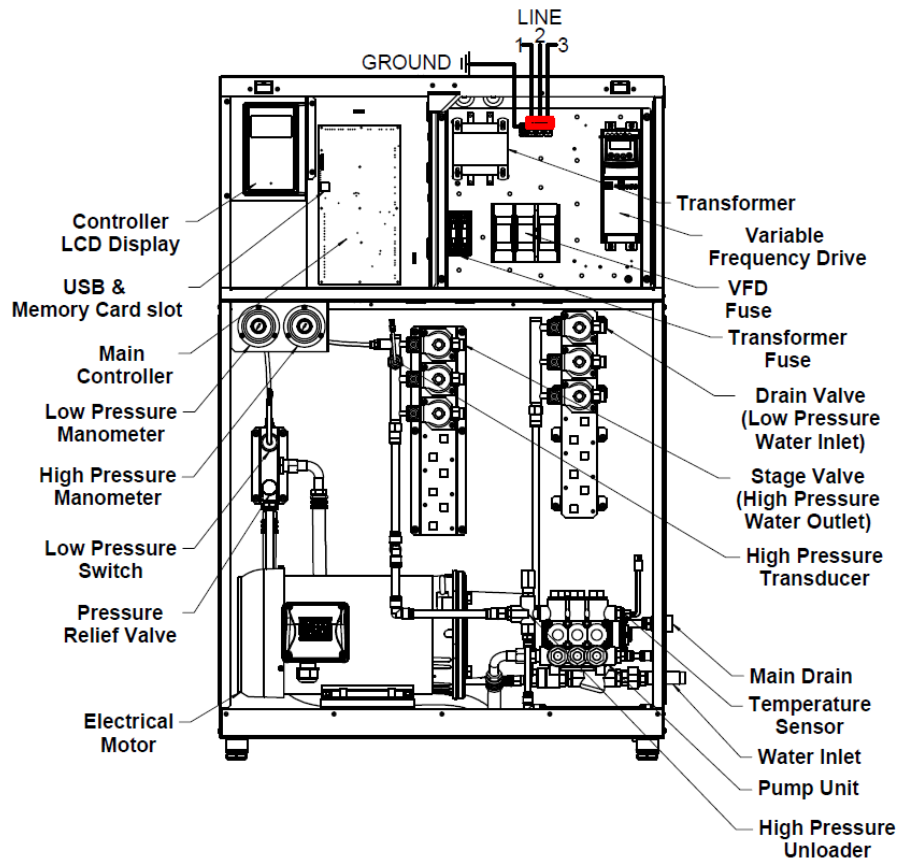

Illustration 2 - Detailed Overview of Components

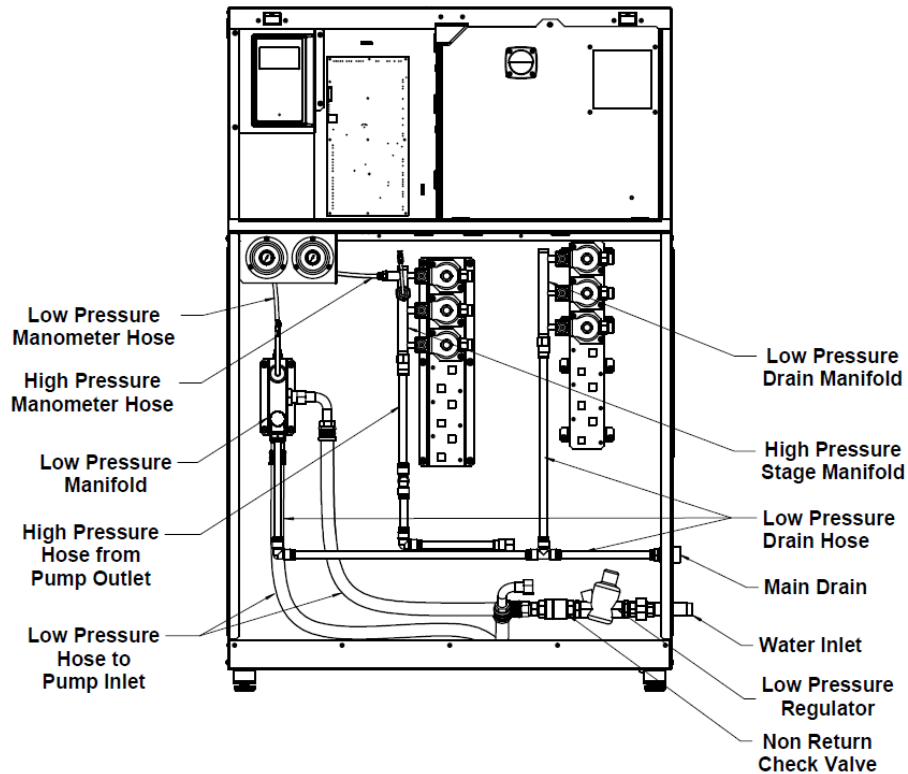

Illustration 3 - Detailed Overview of Low Pressure Components

Pump Unit Nomenclature

Table 1 - Pump Module Nomenclature

Pump Module Nomenclature		
SKH4-ABBBC DD EF		
Designation	Notation	Description
A	N: North America - 60Hz	Frequency
BBB	005 to 300	Capacity (lb/h)
C	B (Brass)	Pump Type
	S (Stainless)	
DD	0 to 6	Number of Inlet Valves (Zero implies valve in the RVP)
	0 to 6	Number of Drain Valves (Zero implies valve in the RVP)
E	A: 120 VAC / 1ph	Supply Voltage
	B: 208 / 1ph	
	C: 220-240 VAC / 1ph	
	D: 208 / 3ph	
	E: 220-240 VAC / 3ph	
	G: 480 VAC / 3ph	
F	[blank] (On/Off)	Motor Control
	M (Modulating - Controlled with VFD)	

Capacities and Power Consumption of the Pump Unit (Brass)

Table 2 - Capacities and Power Consumption of the Pump Unit (Brass)

Brass Pump										
Model	Max output (lb/h)	Min Output (lb/h)	MCA (A)							Cabinet
			A	B	C	D	E	G	H	
			120/1	208/1	240/1	208/3	240/3	480/3	600/3	
SKH4-N021B	210	52	15.0	8.6	7.5	4.9	4.3	2.1	1.7	S
SKH4-N021B - M	210	20	8.4	4.8	4.2	4.8	4.2	2.1	1.7	S
SKH4-N050B	500	125	22.4	12.9	11.2	7.7	6.6	3.3	2.7	S
SKH4-N050B - M	500	20	13.1	7.6	6.6	7.6	6.6	3.3	2.7	S
SKH4-N100B	1000	250	-	-	-	11.3	9.0	4.9	3.9	S
SKH4-N100B - M	1000	20	-	-	9.7	11.2	9.7	4.8	3.9	S
SKH4-N185B	1850	462	-	-	-	22.9	19.8	9.9	8.0	L
SKH4-N185B - M	1850	20	-	-	-	22.8	19.8	9.9	7.9	L
SKH4-N280B	2800	700	-	-	-	22.9	19.8	9.9	8.0	L
SKH4-N280B - M	2800	20	-	-	-	22.8	19.8	9.9	7.9	L

Brass Pump										
Model	Power (HP)	Minimum Wire Gauge (Copper conductors)							Cabinet	
		A	B	C	D	E	G	H		
		120/1	208/1	240/1	208/3	240/3	480/3	600/3		
SKH4-N021B	1/2	14	16	16	16	16	16	16	16	S
SKH4-N021B - M	1/2	16	16	16	16	16	16	16	16	S
SKH4-N050B	1	10	14	14	14	16	16	16	16	S
SKH4-N050B - M	1	14	16	16	16	16	16	16	16	S
SKH4-N100B	2	-	-	-	14	14	14	16	16	S
SKH4-N100B - M	2	-	-	14	14	14	16	16	16	S
SKH4-N185B	5	-	-	-	10	14	12	14	14	L
SKH4-N185B - M	5	-	-	-	10	14	12	14	14	L
SKH4-N280B	5	-	-	-	12	12	14	16	16	L
SKH4-N280B - M	5	-	-	-	12	12	14	16	16	L

Capacities and Power Consumption of the Pump Unit (SS)

Table 3 - Capacities and Power Consumption of the Pump Unit (SS)

Stainless Steel Pump										
Model	Max output (lb/h)	Min Output (lb/h)	MCA (A)							Cabinet
			A	B	C	D	E	G	H	
			120/1	208/1	240/1	208/3	240/3	480/3	600/3	
SKH4-N062S-M	620	62	-	-	18.8	19.0	18.8	9.4	7.5	S
SKH4-N0140S-M	1400	140	-	-	-	29.4	29.1	14.6	11.8	S
SKH4-N0225S-M	2250	225	-	-	-	45.5	45.2	22.6	18.2	L
SKH4-N0280S-M	2800	280	-	-	-	45.5	45.2	22.6	18.2	L
Stainless Steel Pump										
Model	Power (HP)	Minimum Wire Gauge (Copper conductors)							Cabinet	
		A	B	C	D	E	G	H		
		120/1	208/1	240/1	208/3	240/3	480/3	600/3		
SKH4-N062S-M	1 1/2	-	-	14	14	14	14	14	14	S
SKH4-N0140S-M	3	-	-	-	10	10	14	14	14	S
SKH4-N0225S-M	5	-	-	-	8	8	12	14	14	L
SKH4-N0280S-M	5	-	-	-	8	8	12	14	14	L

Dimensions and Weight

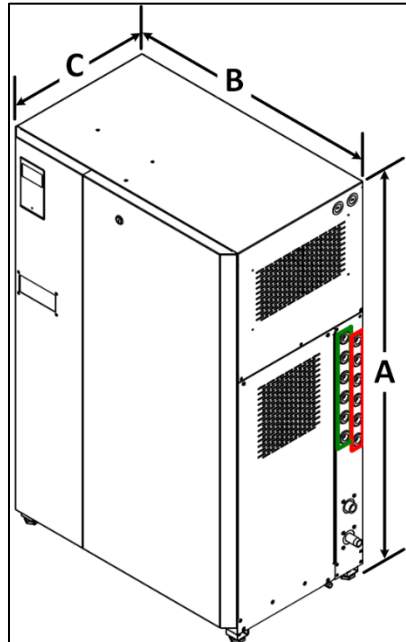

Illustration 4 - SKH4 Pump Unit Dimensions

Table 4 - Pump Station Dimensions (North America)

Enclosure Type	Model	Dimensions (inch) [mm]			Weight (lb) [kg]
		A	B	C	
Small Enclosure	SKH4-N021B	44.5 (1130)	28.5 (724)	13.57 (345)	300 (136)
	SKH4-N050B				
	SKH4-N100B				
	SKH4-N062S				
	SKH4-N140S				
Large Enclosure	SKH4-N175B	46.63 (1184)	30.63 (778)	18.69 (475)	320 (145)
	SKH4-N300B				
	SKH4-N225S				
	SKH4-N280S				

Fan-Assisted Distributors

Fan-Assisted Distributors Nomenclature

Table 5 - Fan-Assisted Distributors Nomenclature

Fan-Assisted Distributors Nomenclature		
SKH4-AAA BBBB C DD		
Designation	Notation	Description
AAA	MDU	Radial distribution unit
	ADU	Axial distribution unit
BBBB	0100 to 2500	CFM
C	A : 120 VAC / 1ph	Supply Voltage
	B : 208 VAC / 1ph	
	C : 240 VAC / 1ph	
DD	01 to 20	Number of spray nozzles

Capacities and Power of the Fan-Assisted Distributors

Table 6 - Fan-Assisted Distributors Capacity and Power

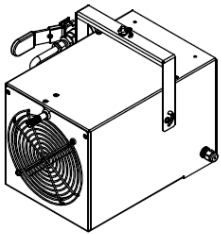
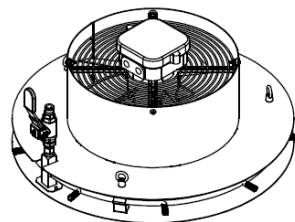
Model	Nozzle Capacity	CFM	Voltage	RLA (A)	Mounting	Illustration
ADU (Axial)	1 (6.6lb/h to 10lb/h)	200	120V (60Hz)	0.9	Wall mounted	
			240V (60Hz)	0.5		
	5 (33lb/h to 50lb/h)	1000	120V (60Hz)	1.4	Wall mounted	
			240V (60Hz)	0.5		
	7 (46lb/h to 70lb/h)	2000	120V (60Hz)	1.5		
			240V (60Hz)	0.9		
MDU (Radial)	9 (60lb/h to 120lb/h)	1000	120V (60Hz)	1.4	Suspended	
			240V (60Hz)	0.5		
	12 (80lb/h to 120lb/h)	2000	120V (60Hz)	1.5		
			240V (60Hz)	0.9		

Fan-Assisted Distributors Dimensions and Weight

Table 7 - Fan-Assisted Distributors Dimensions and Weight

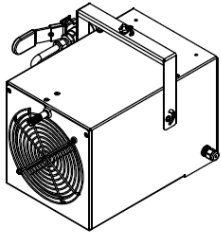
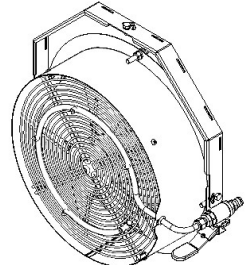
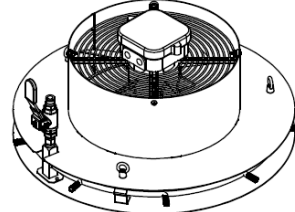
Model	Nozzle Capacity	Dimensions (in) [mm]	Weight (lb) [kg]	Mounting	Illustration
ADU (Axial)	1 (6.6lb/h to 10lb/h) [3l/h to 5l/h]	12.14 x 9.4 x 10.5 [308 x 239 x 267]	8 [3.6]	Wall mounted	
	5 (33lb/h to 50lb/h) [15l/h to 25l/h]	Diameter 18.3 x 8.4 [465 x 213]	17 [7.7]	Wall mounted	
	7 (46lb/h to 70lb/h) [21l/h to 32l/h]	Diameter 23.1 x 9.1 [587 x 231]	25 [11.3]		
MDU (Radial)	9 (60lb/h to 90lb/h) [27l/h to 45l/h]	Diameter 20.3 x 9 [516 x 229]	22 [10]	Suspended	
	12 (80lb/h to 120lb/h) [36l/h to 60l/h]	Diameter 23.5 x 8.7 [597 x 221]	31 [14.1]		

For more information on the absorption distance, please refer to the Distributors Guide.

In-Duct Distribution Rack

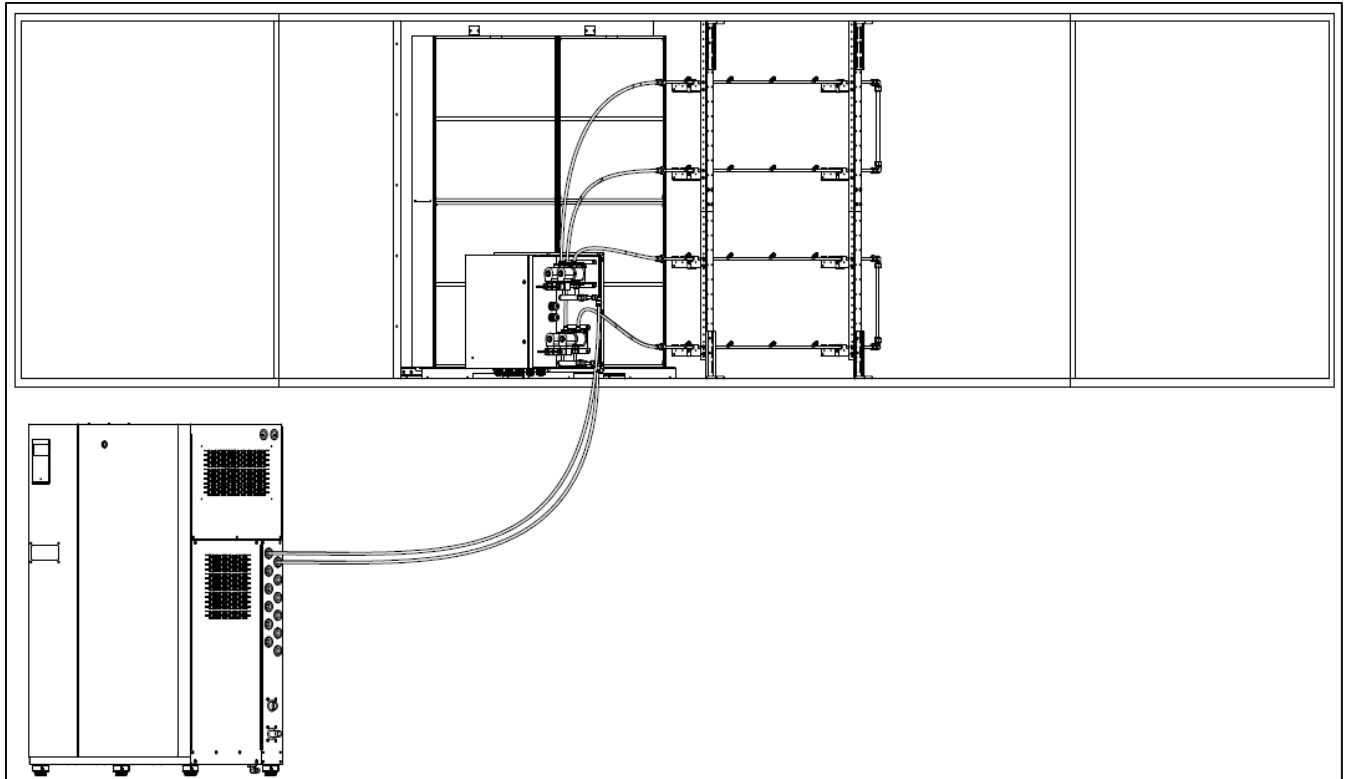

Illustration 5 - In-Duct Distribution

Dimensions and weight vary for each installation, consult with the factory in order to get a quote and detailed drawings for each application.

Refer to the Duct Distribution Guide for more details how to install the duct rack and droplet separator.

Basic Installation Overview



WARNING: Failure to observe manufacturer's installation recommendations voids the manufacturer's warranty.

Installation Summary

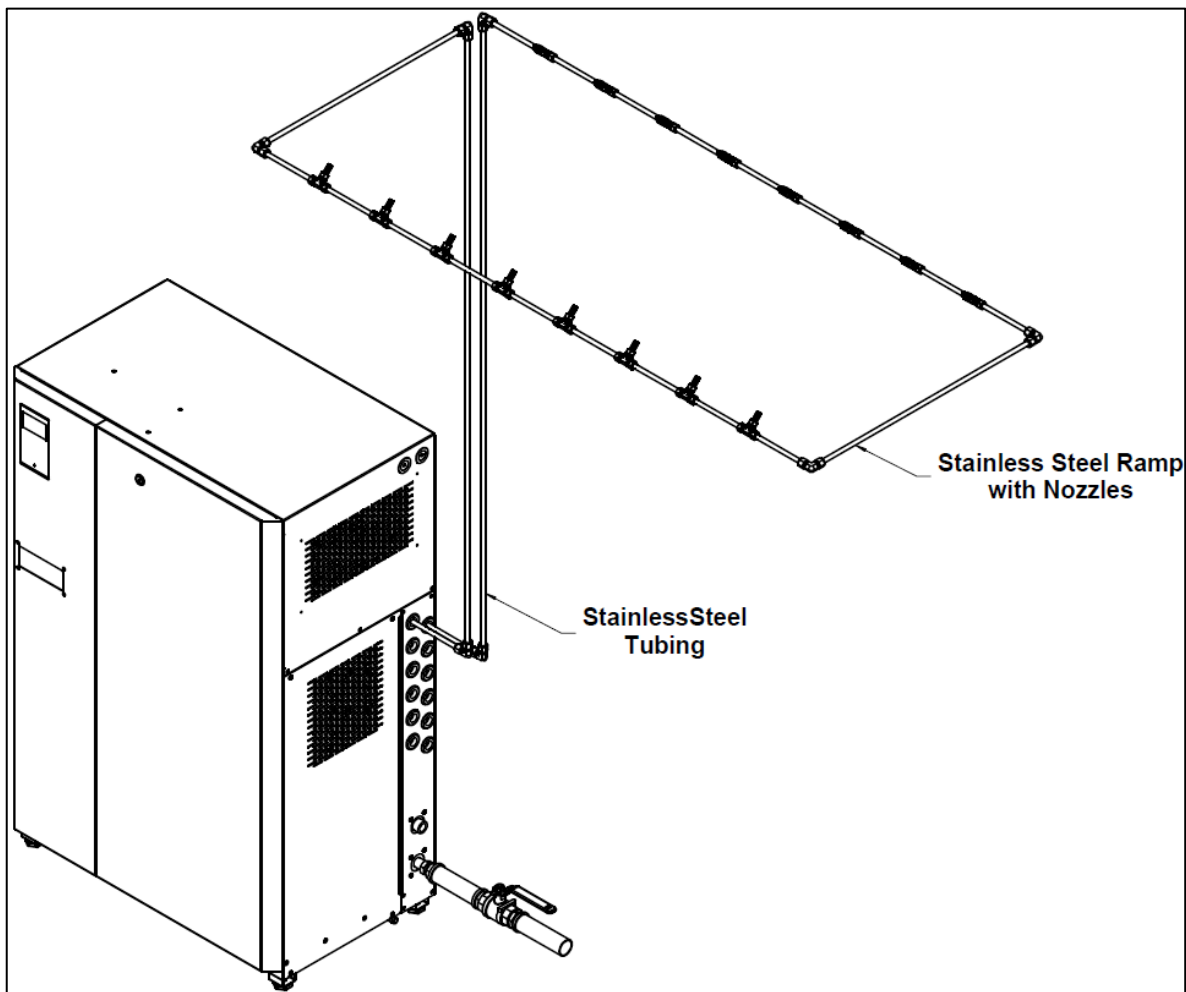

Illustration 6 - Overview of a Typical System Distribution in Space

Pump Unit Installation

- Step 1 – SKH4 Pump Station Installation
- Step 2 – Water and Drain Connections
- Step 3 – Power Supply Connections
- Step 4 – Control Connections
- Step 5 – Pump Controller Installation and Configuration

Step 1 – SKH4 Pump Station Installation

General Recommendations



WARNING: Risk of electric shock. Disconnect the appliance from the electric supply before commencing installation.



CAUTION: Risk of injury. The SKH4 pump station is heavy; It **MUST** always be handled and lifted with care.

Location

Consider the following points before deciding the location for the pump station:

- Plan a location that is easy to access to permit an easy inspection and servicing of the pump station.
- Do not install the pump station where the failure of the appliance could cause damage to the building structure or other equipment.
- Ensure that the location is ventilated appropriately, and that the ambient temperature is less than 86°F (30°C).
- Ensure that the floor beneath the SKH4 pump station is waterproof to withstand any water spillage during servicing or if a problem occurs.

Positioning

- The pump unit can be floor mounted, either directly or with the use of a floor stand, or it can be wall mounted.
- Allow some space beneath the pump station for the drain pan connection, located below the bottom plate.
- Respect the clearances around the pump station as shown in this illustration, in order to permit access to the connections and allow for servicing:

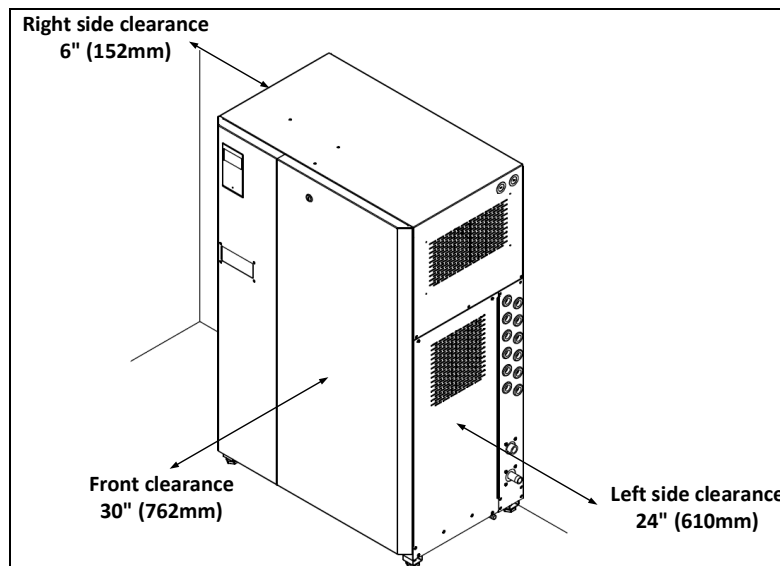

Illustration 7 - Clearances

Floor Mounting

- Provide a level, solid foundation for the SKH4 pump station.
- Ensure that the SKH4 pump station is leveled with the provided with adjustable legs.
- Allow some space beneath the pump station for the drain pan connection, located below the bottom plate.

Wall Mounting

- Provide a level, solid foundation for the SKH4 pump station.
- Allow some space beneath the pump station for the drain pan connection, located below the bottom plate.

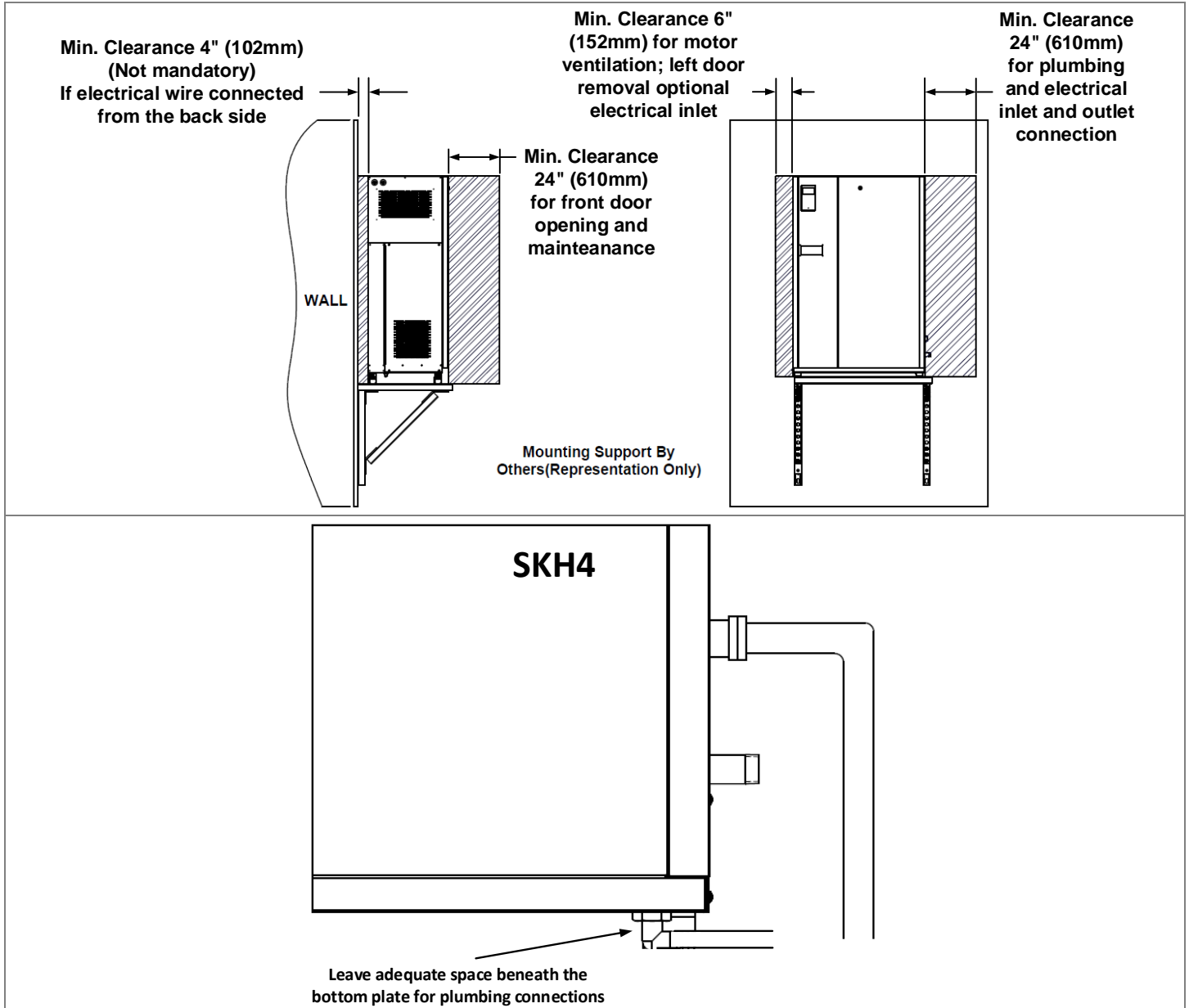

Illustration 8 - Wall Mounting & Clearances

Step 2 – Water Connections for the SKH4 Pump Station

- Install an isolation valve (not supplied) on the water line near the pump station inlet for ease of maintenance and servicing. Place the valve in front of the water filter if used.
- Flush the water line thoroughly before connecting the feed water pipework to the pump station.

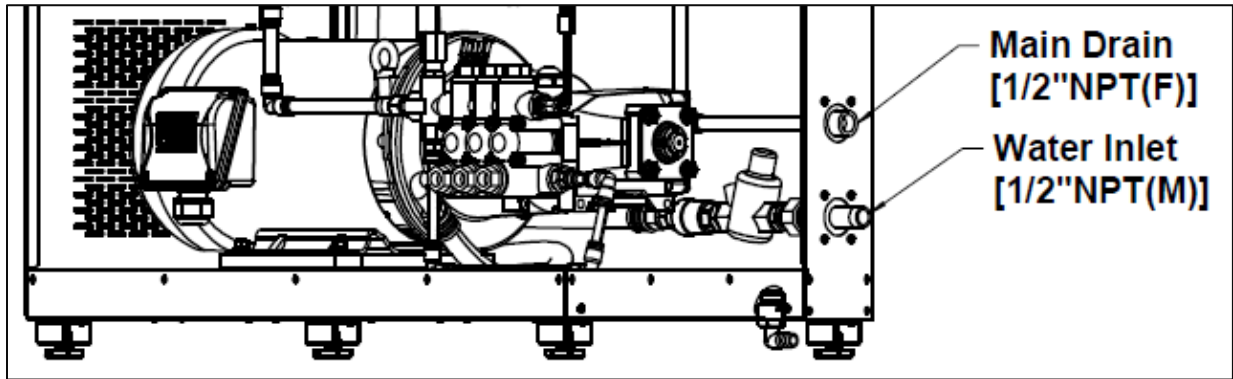

Illustration 9 - Water Connections for Pump Station

i Note: Do not over tighten the hose fittings as this may damage the seals.

Table 8 - Water Supply and Drain Connection Specifications

Specification		All Models
Water Supply	Water supply size	Male NPT 1/2" (DN15)
	Minimum water supply pressure	30 PSI (2.0 bar)
	Maximum water supply pressure	70 PSI (4.8 bar)
	Minimum water supply temperature	38°F (3°C)
	Maximum water supply temperature	77°F (25°C)
Water supply quality		Stainless Steel Pump: 5-20 µS/cm
		Brass Pump: 10-80 µS/cm
Drain outlet size	Drain outlet size	Female NPT 1/2" (DN15)
	Pan drain outlet size	7/8" Round tube

Water Supply

- Connect the female NPT connection of the water supply inlet of the humidifier to a high quality water source.
- The SKH4 requires high quality water to prevent scale build-up and clogging of the spray nozzles, resulting in frequent replacement of nozzles. Poor water quality is also damaging to the pump. Furthermore, most of the minerals contained in the water are sprayed into the air.
- Brass pumps are compatible with tap water, reverse osmosis (RO) and deionized water (DI), although RO water is preferable, in the conductivity range of 10-80 $\mu\text{S}/\text{cm}$.
- Stainless steel pumps require high quality water, tap water will cause irreversible damage quickly. RO or DI water in the 5-20 $\mu\text{S}/\text{cm}$ conductivity range is recommended.
- If the supplied water is treated with reverse osmosis or deionization filtration, control the total dissolved solid contents in the water to be above the minimum recommended (see Table 8), as there is no need for ultra-pure water.

High-Pressure Water Outlets

- High-pressure water outlets use a 3/8" (DN10) flexible high-pressure nylon hose (available upon request) connected to a push-to-connect 3/8" fittings (supplied) with the respective stage and drain valves.
- Alternatively, stainless steel rigid piping with compression fittings or 1/2" (DN15) flexible high-pressure nylon with matching push-to-connect hose can also be used at the outlets (available upon request).
- (Optional) If using a remote valve panel (RVP), connect the RVP inlet manifold to a single outlet from the pump unit to minimize pressure losses. Connections are made using a 3/8" (DN10) or 1/2" (DN15) flexible high-pressure nylon hose or a high-pressure hydraulic hose or stainless steel rigid piping (available upon request). (See RVP section)



Note: Ensure that the rating of the flexible hose is appropriate for the operating pressure (1000PSI / 70bar).

Water Drain

- Connect a 1/2" NPT (DN15) pipe (not supplied) to the 1/2" NPT female (DN15) drain outlet to an open drain outlet.
- The pan drain is located below the base of the SKH4 pump station and is directed towards the main building open drain.
- The open drain pipe must have a minimum diameter of 1-1/2" (DN40).



WARNING: Risk of flooding. Never connect the drains to a closed piping network.

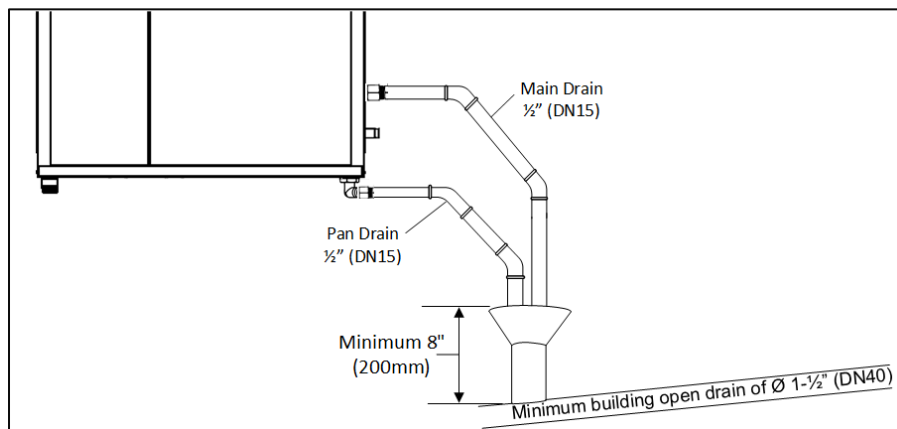

Illustration 10 - Water Drain Connections

Step 3 – Power Supply Connections



WARNING: All work concerned with electrical installation **MUST** only be performed by skilled and qualified technical personnel, such as electricians or technicians with appropriate training. The customer is responsible for ensuring their suitability.



WARNING: Risk of electric shock. Isolate all power supplies before installation and maintenance of the SKH4 High-Pressure Atomizer or the RVP.



You MUST externally fuse all incoming power supplies for over current protection.
Observe local codes and regulations concerning the provision of electrical installations.

The installation engineer must ensure the following:

- Use copper power conductors only.
- Ensure that the size of the power conductors is suitable for the maximum current supplied.
- Secure incoming power cables using a suitably sized cable gland.
- Secure each terminal connection with a cable ferrule.
- Do not use the SKH4 pump station's frame to connect to ground. The SKH4 pump station cabinet has a provision for the electrical ground.

Power Supply Connections on SKH4 Pump Station

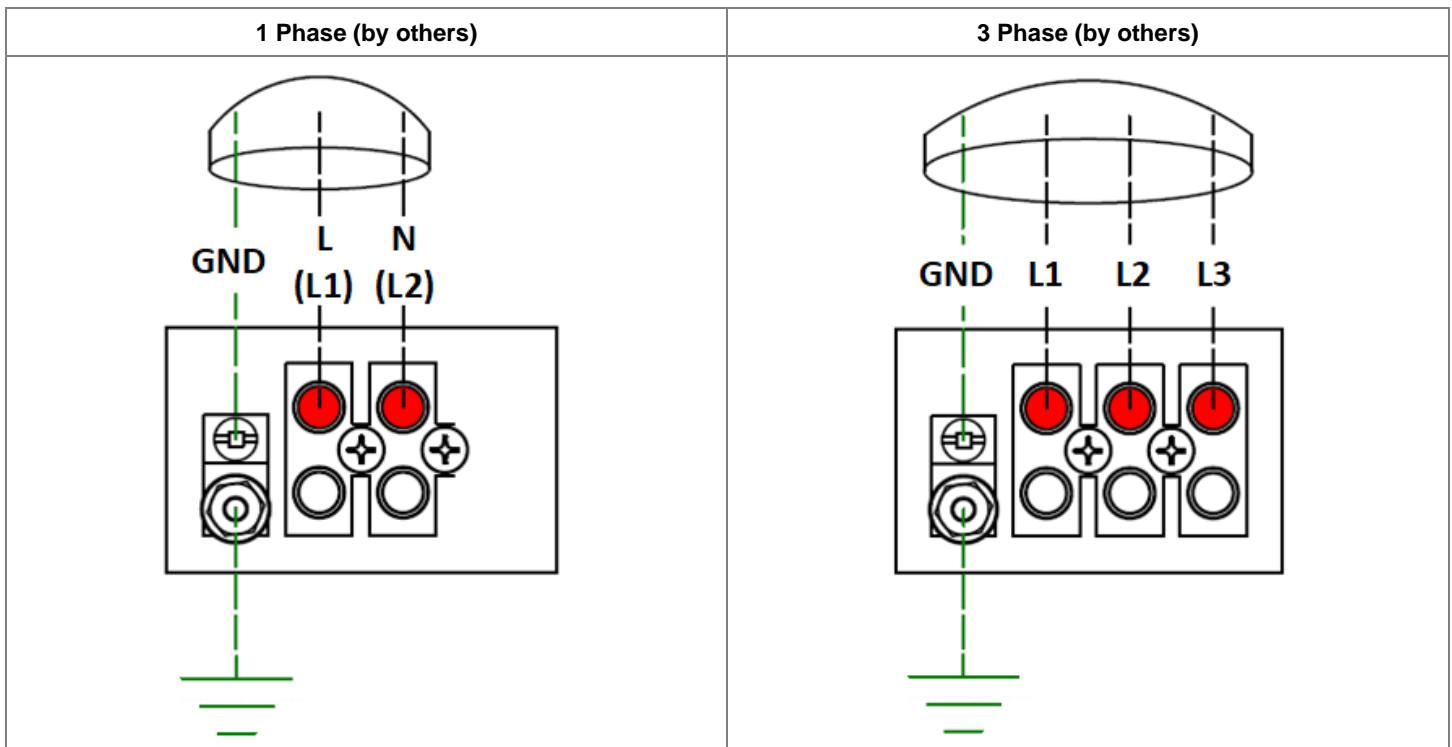

Illustration 11 - One and Three Phase Power Supply Connections

Power Supply Knockout Holes Location on SKH4 Pump Station

Connect high power cable through the knockout holes provided on the unit. Alternative points are given depending on the installation constraints.

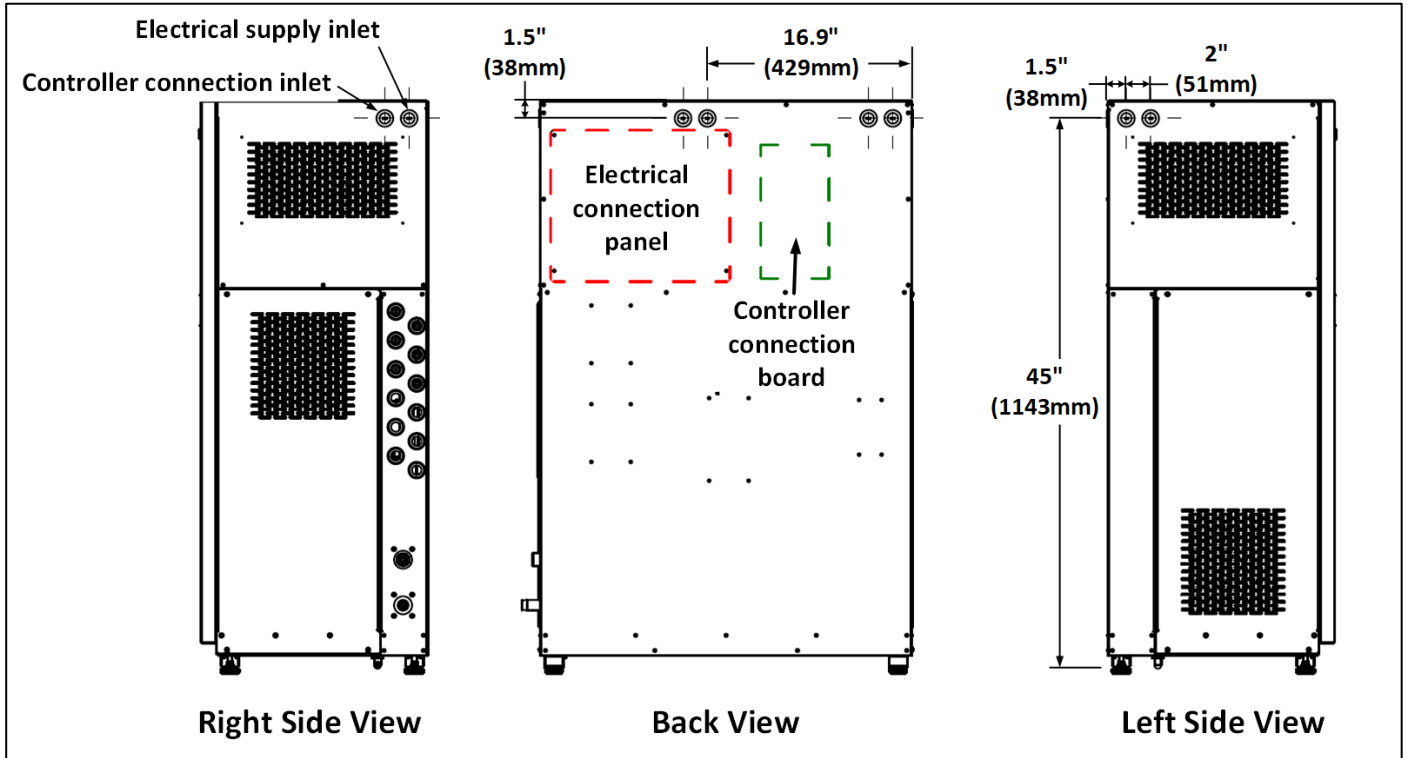

Illustration 12 - Power Supply Knockout Holes

Step 4 – Electrical Control Connections



WARNING: All work concerned with electrical installation **MUST** only be performed by skilled and qualified technical personnel, such as electricians or technicians with appropriate training. The customer is responsible for ensuring their suitability.



WARNING: Risk of electric shock. Isolate all power supplies before installation and maintenance of the SKH High-Pressure Atomizer.

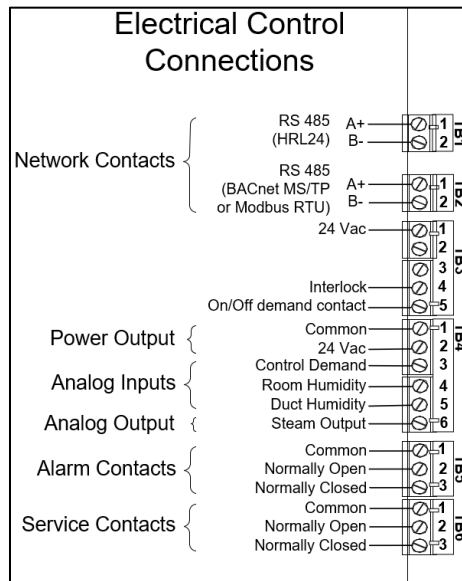

Illustration 13 - Electrical Control Connections

Safety Contact Connections for Pump Unit

Available directly on the pump unit, this safety contact will interrupt all actions of the pump unit, for all zones.

- *Interlock.* Wire the switch on the PCB between terminals TB3 1&4. If this contact opens, the operation of the SKH4 unit stops all zones and an **Alarm** will be displayed. If the interlock is not used, install a jumper between terminals TB3 1&4.

Safety Contact Connections Single Zone Without TRUB

- *Interlock.* Wire the switch on the PCB between terminals TB3 2&3. If this contact opens, the operation of the SKH4 unit stops all zones and an **Alarm** will be displayed. If the interlock is not used, install a jumper between terminals TB3 2&3.

Safety Contact Connections per Zone from TRUB

Available on each TRUB, these will have an effect only the associated zone, other zones will continue their operation:

- *Airflow Switch (Activated option).* Wire the contact on the TRUB between the recommended terminals TB2 2 (COM) & 3 (UI3). If this contact opens, the operation of the valve(s) will stop. The unit displays the Airflow switch as 'open' but will **not** generate an alarm. (refer to the configuration menu)
- *High Limit Humidistat (Activated option).* Wire the contact on the TRUB between the recommended terminals TB1 13 (COM) & 15 (UI2). If this contact opens, the operation of the valve(s) will stop, and an **Alarm** will be displayed. If spraying in-space, the high limit humidistat is not required.
- *Interlock.* Wire the switch on the TRUB between the recommended terminals TB2 2 (COM) & 4 (UI4). If this contact opens, the operation of the SKH4 unit stops and an **Alarm** will be displayed.

For more information, consult the TRUB documentation.

Network Communication

If the control signal is from BACnet MS/TP or Modbus RTU network, connect terminals TB2 1&2 to the network (RS485 A+ & B-).

If the control signal is from a network of one or multiple TRUB, connect terminals TB1 1&2 to the network (RS485 A+ & B-).

The network control signal(s) must be selected by accessing the *Control* sub-menu located in the *Installation* menu (see page 58). To setup the communication parameters, access the *Integration* menu (see page 41).



Note: BACnet MS/TP is configured by default. To change the communication interface to Modbus RTU, access the NtwrkOption setting located in the Network sub-menu of the Integration menu (see page 41).

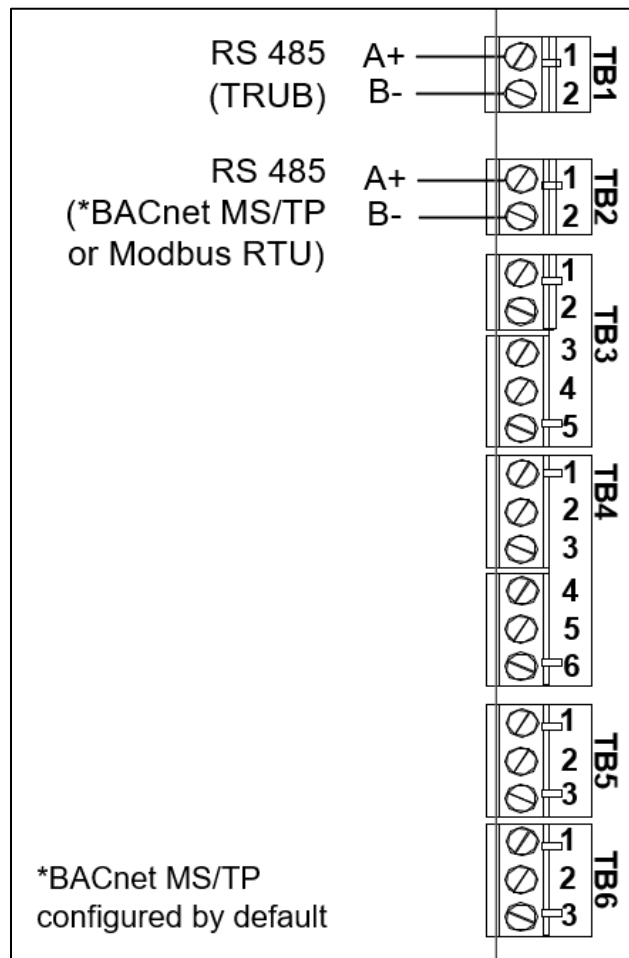

Illustration 14 - Network Communication Connections

BACnet – Network

The SKH4 master pump station may use BACnet or Modbus protocols to communicate, either with an IP connection or MS/TP.

Step 5 – Pump Controller Installation and Configuration

User Interface

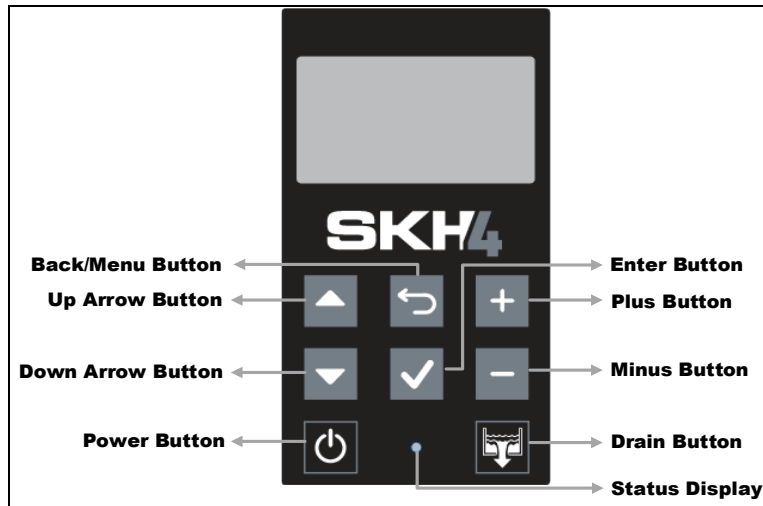













Illustration 15 - SKH4 Controller

Controller Panel Features

The following are the features of the Control Panel and their description:

Table 9 - Humidifier Control Panel Description

Feature		Description
Status Display	 (Blue)	Indicates that the humidifier is turned on. The LED will begin blinking as the system is initializing.
	 (Red)	Indicates that the humidifier is issuing an alarm or warning and that the system must be verified.
	 (Off)	Indicates that the humidifier is turned off.
Power Button		The power button is used to turn the humidifier on or off. Must be pressed and held for 3 seconds to perform the related action, in order to prevent accidental activation. Even when the humidifier is powered off, the controller remains operational.
Drain Button		The drain button is used to manually activate the drain cycle. Must be pressed and held for 3 seconds to perform the related action, in order to prevent accidental activation. Even when the humidifier is powered off, a manual drain cycle may be initiated. <i>Once the manual drain cycle is completed, the system will automatically be powered off. To turn the humidifier back on, press and hold the power button.</i>
Up and Down Arrow Buttons		The up arrow button is used to scroll to the next menu item or parameter.
		The down arrow button is used to scroll to the previous menu item or parameter.
Plus and Minus Buttons		The plus button is used to increase the value of the displayed parameter.
		The minus button is used to decrease the value of the displayed parameter.
Back/Menu Button		The back/menu button is used to go to previous menu or to access the Main Menu page from the Idle Screen.
Enter Button		The enter button is used to advance to the next sub-menu, to access selected option or to confirm set parameter value.

Idle Screen

When the controller is in operation, the unit displays the following information on the Idle Screen:

Table 10 - Idle Screen Display Description

Setting	Default	Range (* indicates no configuration; display only)	Description/Notes
Pressure:	Current value	* (min: 0 psi, max: 10000 psi)	Displays the current value of the pump pressure.
ControlState:	Current value	* (Off, Normal, LowLimit, HighLimit, NoAirFlow, Interlock)	Displays the current state of the safety control circuit and whether the circuit has been disconnected due to a safety switch.
State:	Current value	* (Off, Idle, LineRinse, TankRinse, Filling, Draining, Heating, Boiling, Alarm)	Displays the current state of operation of the humidifier.
ZonexDemand:	Current value	* (min: 0.00%, max: 100.00%)	Displays the value of demand for the selected zone.

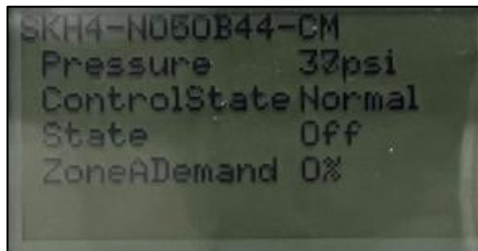

Illustration 16 - Idle Screen Display

Menu Access

- From the Idle Screen, the Main Menu can be accessed by pressing the Back/Menu button, enabling access to the General menu.
- To view other menu options and perform configurations to the system, press Enter while on the Idle Screen to advance to the Login Screen, where a valid password must be entered.
- Four different passwords can be used, each granting access to an additional menu option depending on the access level assigned to the provided password.
- If a password of higher access is provided, all menu options accessible with the use of a lower-level password will also be unlocked.

Table 11 - Access Levels

Access Level	Password	Menu Unlocked	Description/Notes
1	None	General	Grants access to General menu.
2	2222	User	Grants access to General and User menus.
3	3322	Service	Grants access to General, User and Service menus.
4	4433	Installation	Grants access to General, User, Service and Installation menus.
5	5544	Integration	Grants access to General, User, Service, Installation and Integration menus.



Note: To modify or retrieve lost passwords, please contact factory.

Configuration parameters

In the menu *Installation/quickConfig/Stage[]*, each stage needs to be defined. Input which zone (control signal) each stage is connected to and input the capacity (L/h) for the stage control. Input the drain valve associated with the stage valve (the two valves should form a loop with the nozzles in between).

The drain volume can be increased if the line is very long, in order to ensure depressurization of the line.

Control function

Ramp up: In the menu *Installation/quickConfig/Zone[]/StgOpenDelay*, this parameter allows a user to add a delay between the opening of the stages, for each zone separately. When that time value is higher than zero, the smallest stage will open, followed by the second smallest after the delay parameterized. The output increases progressively, which results in less intense variation in the system, which results in the control being more precise and reduces the risk of overshooting during the startup process.

Pulse settings: In the menu *Installation/quickConfig/Stage[]*, the *MaxOnTime* and *PauseTime* features allow the user to make the stages pulse. This feature can be useful in order to shorten absorption distances by allowing a time pause between the addition of water in the air which eases the absorption. This parameter should only be used with multi stage zones, in order to prevent the short cycling of the pump and motor. If the humidification by pulse stops and starts the motor in a period shorter than 5 min, revise the pulse setting to prevent damages to the pump unit components.



WARNING: The parameters for setting the pulse frequency should be validated with a test in order to make sure the pump and motor do not start and stop too frequently within 5 minutes, as this may damage the pump or the electrical components.

Control Profile Selection

In order to select the desired control profile, first determine the signal type to be used (by demand [external profile] or sensor [internal profile]). Next, determine whether the humidifier is going to be controlled via a *network* or by an *analog signal* from the following options based on the number of zones:

Single Zone Operation

Control Profile – External Signal – Analog

The unit expects a demand signal in the form of a 0-10V, wired on the pump unit's control board, on pin TB4 3. The unit follows that demand directly and activates the respective valves in order to minimize the error between the output and the demand. This configuration requires a thermostat.

Control Profile – External Signal – Network

The unit expects a demand signal, coming from the network. Set the demand using the object *AV.138 Control Network Demand*. This configuration requires a thermostat and a BMS.

Note: The main controller board inside of the pump unit needs be equipped with the option of network, either with the IP connection or the MS/TP connection. Both Modbus and BACnet protocols are supported.

Control Profile – Internal Signal – Analog

The pump unit's control board receives a 0-10V signal from the setpoint reading and a room temperature/humidity input from a sensor through the control input on TB4 pin 3, and then calculates internally the PID (proportional, integral, and derivative) control responses and computes the desired outputs. This configuration requires temperature/humidity sensor(s). Refer to Table 12 - Complete List of Configurable Objects for complete list of configurable objects.

Control Profile – Internal Signal – Network

The unit expects either a temperature demand signal (set using object *AV.155 Control Network Demand* and object *AV.156 Room temperature setpoint*) or a humidity demand signal (set using object *AV.106 Room RH Network Reading* and object *AV.107 Room RH Setpoint*), coming from the network and then calculates internally the PID (proportional, integral, and derivative) control responses and computes the desired outputs. This configuration requires temperature/humidity sensor(s) and a BMS. Refer to Table 12 - Complete List of Configurable Objects for complete list of configurable objects.

Note: The main controller board inside of the pump unit needs be equipped with the option of network, either with the IP connection or the MS/TP connection. Both Modbus and BACnet protocols are supported.

Table 12 - Complete List of Configurable Objects

PID Loop Configuration	
Control Profile	Configurable Objects
Internal Analog/Network Humidity	1. AV.110 Room RH Demand Proportional Gain 2. AV.111 Room RH Demand Integral Time 3. AV.112 Room RH Demand Derivative Time 4. AV.230 Room RH Demand Proportional Band 5. AV.108 Room RH Unoccupied Setpoint 6. AV.109 Room RH Vacant Setpoint
Internal Network Temperature	1. AV.159 Room Temperature Demand Proportional Gain. 2. AV.160 Room temperature Demand Integral Time. 3. AV.161 Room Temperature Demand Derivative Time. 4. AV.174 Room Temp Demand Proportional Band. 5. AV.157 Room Temperature Unoccupied Setpoint. 6. AV.158 Room Temperature Vacant Setpoint.

Multi-Zones Operation

Control Profile – External Signal – Analog

Same description as the single zone operation.

TRUB Controller

When using a TRUB thermostat, connect the PCB controller to the TRUB. For more details, consult the TRUB documentation.

Menu - General [Level 1 - No password required]

Press the back/menu button from the Idle Screen to access the General menu.

Sub-Menu	Setting	Default	Range (* indicates no configuration; display only)	Description/Notes	
Status	SysPowerState:	Off	* (Off, On)	Displays the status of the system power state.	
	Airflow:	Closed	* (Closed, Open)	Displays the status of the airflow switch. If <i>Open</i> is displayed, it indicates that the airflow is not detected by the air pressure switch.	
	SupplyHighLimit:	Closed	* (Closed, Open)	Displays the status of the high limit contact. If <i>Open</i> is displayed, it indicates that the humidity level has exceeded the setpoint on the high limit humidistat.	
	Interlock:	Closed	* (Closed, Open)	Displays the status of the interlock. If <i>Open</i> is displayed, it indicates that the humidifier is stopped as a result of the interlock safety being open.	
	State:	<i>Current value</i>	* (Off, Idle, Spraying, Draining, Alarm)	Displays the current state of operation of the humidifier.	
	Pressure:	<i>Current value</i>	* (min: 0 psi, max: 10000 psi)	Displays the current value of the pump pressure.	
	ControlState:	Off	* (Off, On)	Displays the status of the control state.	
	ZoneA to D		[6]		
		ZoneADemand to D:	50%	* (min: 0%, max: 100%)	Displays the value of demand for the zone.
		Temperature:	68.0°F [20.0°C]	* (min: -40.0°F, max: 302.0°F) * [min: -40.0°C, max: 150.0°C] Units: C, F	Displays the value of temperature for the zone.
	Humidity:	0.00%RH	min: 0.00%RH max: 100.00%RH Units: %RH	Displays the valve humidity for the zone.	
	Control:	Off	* (Off, Normal, Airflow, SupplyHighLimit, Interlock)	Displays the current state of the safety control circuit and whether the circuit has been disconnected due to a safety switch.	
	Occupancy:	Occupied	* (Occupied, Unoccupied, Vacant, Off)	Displays the current occupancy state.	
Control	RoomTempDemand:	<i>Current value</i>	* (min: 0%, max: 100%)	Displays the room temperature demand value. Only appears if there is a single zone and ControlProfile is set to an internal control mode or DemandSrc is set to TempRoomDemand.	
	TempSupplyHLDemand:	<i>Current value</i>	* (min: 0%, max: 100%)	Displays the supply high limit temperature demand value. Only appears if there is a single zone and ModHLProfile is set to an internal control mode or HighLimitSrc is set to TempSupplyHLDemand or if there's a single zone.	
	RoomRHDemand:	<i>Current value</i>	* (min: 0%, max: 100%)	Displays the room humidity demand value. Only appears if there is a single zone and ControlProfile is set to an internal control mode or DemandSrc is set to HumRoomDemand.	
	RHSupplyHLDemand:	<i>Current value</i>	* (min: 0%, max: 100%)	Displays the supply high limit humidity demand value. Only appears if there is a single zone and ModHLProfile is set to an internal control mode or HighLimitSrc is set to RHSupplyHLDemand.	
Physical IO	AirFlow:	Closed	* (Closed, Open)	Displays the status of the airflow switch. If <i>Open</i> is displayed, it indicates that the airflow is not detected by the air pressure switch.	
	SupplyHighLimit:	Closed	* (Closed, Open)	Displays the status of the high limit contact. If <i>Open</i> is displayed, it indicates that the humidity level has exceeded the setpoint on the high limit humidistat.	



Physical IO	Interlock:	Closed	* (Closed, Open)	Displays the status of the interlock. If <i>Open</i> is displayed, it indicates that the humidifier is stopped as a result of the interlock safety being open.
	Pressure:	<i>Current value</i>	* (min: 0 psi, max: 10000 psi)	Displays the value of the pump pressure.
	InPressSwitch:	Low	*(Low, Ok)	Displays the status of inlet pressure switch.
	ControllInput:	<i>Current value</i>	* (min: 0%, max: 100%)	Displays the current control input humidity reading.
	ControllInput:	<i>Current value</i>	* (min: -40.0°F, max: 302.0°F) * [min: -40.0°C, max: 150.0°C] Units: C, F	Displays the current control input temperature reading.
	RoomTemp:	<i>Current value</i>	* (min: -40.0°F, max: 302.0°F) * [min: -40.0°C, max: 150.0°C] Units: C, F	Displays the room temperature reading value. (Only appears if <i>ControlProfile</i> is set to <i>InternAnalog</i> or <i>RoomRHsrc</i> is set to <i>RoomRH</i>.)
	SupplyHLRH:	<i>Current value</i>	* (min: 0%, max: 100%)	Displays the supply high limit humidity reading value.
	SupplyHLTemp:	<i>Current value</i>	* (min: -40.0°F, max: 302.0°F) * [min: -40.0°C, max: 150.0°C] Units: C, F	Displays the supply high limit temperature reading value. (Only appears if <i>ModHLProfile</i> is set to <i>InternAnalog</i> or <i>SupplyHLReadingSrc</i> is set to <i>SupplyHLRH</i>.)
	WaterTemp:	<i>Current value</i>	* (min: 32.0°F, max: 257.0°F) * [min: 0.0°C, max: 125.0°C] Units: C, F	Displays the temperature of water in the evaporation chamber.
	WtrLeakDet:	Ok	* (Ok, Leak)	Displays whether a water leak has been detected. If <i>Leak</i> is displayed, it indicates that there is a leak within the water line.
	DriveEnable:	Off	* (Off, On)	Displays the status of the drive enable.
	DriveStatus:	Ok	* (Ok, Fault)	Displays the status of drive.
	DriveSignal:	0.000V	* (min: 0.000V, max: 10.000V)	Displays the value of the drive signal.
	MotorSpeed:	<i>Current value</i>	* (min: 0%, max: 100%)	Displays the value of the motor speed.
	Contactorpump:	Off	* (Off, On)	Displays the status of the contactor pump.
	AlarmRelay:	Off	* (Off, On)	Displays the status of the alarm warning relay.
	RelayFuse:	<i>Normal</i>	* (Normal, Blown Fuse)	Displays the current status of the PCB fuse. If <i>Blown Fuse</i> is displayed, the fuse must be replaced.
	ServiceRelay:	<i>Current value</i>	* (Off, On)	Displays the status of the service warning relay.
	Valve1	Off	* (Off, On)	Displays the status of the valve 1.
	Valve2	Off	* (Off, On)	Displays the status of the valve 2.
Valve3	Off	* (Off, On)	Displays the status of the valve 3.	
Valve4	Off	* (Off, On)	Displays the status of the valve 4.	
Valve5	Off	* (Off, On)	Displays the status of the valve 5.	
Valve6	Off	* (Off, On)	Displays the status of the valve 6.	
Valve7	Off	* (Off, On)	Displays the status of the valve 7.	
Valve8	Off	* (Off, On)	Displays the status of the valve 8.	
Valve9	Off	* (Off, On)	Displays the status of the valve 9.	
Valve10	Off	* (Off, On)	Displays the status of the valve 10.	
Valve11	Off	* (Off, On)	Displays the status of the valve 11.	
Valve12	Off	* (Off, On)	Displays the status of the valve 12.	
System	SysStatus:	Operational	* (Operational, Operational Read-Only, Download required, Download in progress, Non-operational, Backup in progress)	Displays the current system status.
	Vendor:	Neptronic	*	Displays the name of the vendor of the product. (Always Neptronic)
	Model:	-	*	Displays the humidifier model name.
	AppVersion:	0.11.20230731	*	Displays the current application software version.
	SerialNo:	-	*	Displays the serial number of the humidifier.
Profile:	- SKH4 Controller	*SKH4 Controller		Displays a short profile for the configured device.



System	MCULoad:	<i>Current value</i>	* (min: 0%, max: 100%)	Displays the current microcontroller load.
	MemoryLoad:	<i>Current value</i>	* (min: 0%, max: 100%)	Displays the current memory load.
	Runtime:	<i>Current value</i>	* (min: 0 sec, max: 999999999 sec)	Displays the number of seconds that the system has been powered on. This value is reset every time the system is shut off.
	ResetReason:	None	* (None, BOR, Pin, POR, Soft, IWDG, WWDG, LPWR, Unknown)	Displays the reason for the previous system reset: <i>None = No Reset; BOR = Brownout Reset; Pin = Pin Reset (using PCB Reset Button); POR = Power-on Reset; Soft = Software Reset; IWDG = Independent Watchdog; WWDG = Windowed Watchdog; LPWR = Low Power Reset; Unknown = Unknown Cause</i>



Menu - User Settings [Level 2 - Requires level 2 (or higher) password in order to access]

Sub-Menu	Setting	Default	Range	Description/Notes	
Command	DrainSchedule:	-	00:00 Monday to Sunday Event 1 to Event 6	Create a customized draining schedule with up to six events per day.	
	OccupSchedule:	-	00:00 Monday to Sunday Event 1 to Event 6	Create a customized occupancy schedule with up to six events per day.	
Control	RoomTempDemandLoop [3]			Only appears if there is a single zone and ControlProfile is set to an internal control mode or DemandSrc is set to TempRoomDemand.	
		OccStp:	40.0%	min: 0.0%, max: 100.0%	Define the room temperature demand setpoint value used during <i>Occupied</i> state. Only appears if there is a single zone and RoomTempDemandLoopStptSrc is set to Internal.
		UnocStp:	30.0%	min: 0.0%, max: 100.0%	Define the room temperature demand setpoint value used during <i>Unoccupied</i> state.
		VacantStp:	20.0%	min: 0.0%, max: 100.0%	Define the room temperature demand setpoint value used during <i>Vacant</i> state.
	TempSupplyHLLoop [3]			Only appears if there is a single zone and ModHLProfile is set to an internal control mode or HighLimitSrc is set to TempSupplyHLDemand.	
		OccStp:	80.0%	min: 0.0%, max: 100.0%	Define the supply high limit temperature demand setpoint value during <i>Occupied</i> state. Only appears if there is a single zone and TempSupplyHLLoopStptSrc is set to Internal.
		UnocStp:	30.0%	min: 0.0%, max: 100.0%	Define the supply high limit temperature demand setpoint value used during <i>Unoccupied</i> state.
		VacantStp:	20.0%	min: 0.0%, max: 100.0%	Define the supply high limit temperature demand setpoint value used during <i>Vacant</i> state.
	RoomRHDemandLoop [3]			Only appears if there is a single zone and ControlProfile is set to an internal control mode or DemandSrc is set to HumRoomDemand.	
		OccStp:	40.0%	min: 0.0%, max: 100.0%	Define the room humidity demand setpoint value used during <i>Occupied</i> state. Only appears if there is a single zone and RoomRHDemandLoopStptSrc is set to Internal.
		UnocStp:	30.0%	min: 0.0%, max: 100.0%	Define the room humidity demand setpoint value used during <i>Unoccupied</i> state.
		VacantStp:	20.0%	min: 0.0%, max: 100.0%	Define the room humidity demand setpoint value used during <i>Vacant</i> state.
	RHSupplyHLLoop [3]			Only appears if there is a single zone and ModHLProfile is set to an internal control mode or HighLimitSrc is set to RHSupplyHLDemand.	
		OccStp:	80.0%	min: 0.0%, max: 100.0%	Define the supply high limit humidity demand setpoint value during <i>Occupied</i> state. Only appears if there is a single zone and RHSupplyHLLoopStptSrc is set to Internal.
		UnocStp:	30.0%	min: 0.0%, max: 100.0%	Define the supply high limit humidity demand setpoint value used during <i>Unoccupied</i> state.
	VacantStp:	20.0%	min: 0.0%, max: 100.0%	Define the supply high limit humidity demand setpoint value used during <i>Vacant</i> state.	
System	UTCOffset: -300min	-300min	min: -720min, max: 720min	Configure the value of the UTC offset.	
	DaylightSavings: No	No	No, Yes	Select whether to enable daylight savings or not.	
	LocalDateTime:	YYYY-MM-DD 00:00:0		Configure the current date and time.	



		LocalDisplay [5]		
Interface	BacklightLvl:	25%	min: 0%, max: 100%	Select the backlight level of the LCD screen.
	Contrast:	10%	min: 0%, max: 30%	Select the contrast level of the LCD screen.
	MenuTimeout:	300sec	min: 30sec, max: 1800sec	Set the value of the local menu timeout.
	KeypadBuzzer	Inactive	Inactive, Active	Select whether to enable or disable the key press sound.
	Language:	English	English, French, Spanish	Select the device language.
	Units:	Imperial	Metric, Imperial	Select whether to use a metric or imperial system of units for the local device.



Menu - Service [Level 3 - Requires level 3 (or higher) password in order to access]

Sub-Menu	Setting	Default	Range (* indicates no configuration; display only)	Description/Notes
Status	OnTime:	0.00hr	*	Displays the total operating time of the unit.
	ServOnTime:	0.00hr	*	Displays the operating time of the unit, since the last servicing.
	Stage1 to 6 [5]			
	CycleCount:	0	*	Displays the total cycle count of the stage valve.
	RunTime:	0.00hr	*	Displays the total runtime of the unit.
	OnTime:	0.00hr	*	Displays the total operating time of the unit.
	IdleTime:	0.00hr	*	Displays the amount of time the humidifier can remain in standby mode until an automatic drain cycle is performed.
	DrainTime:	0sec	*	Displays the frequency of the drain cycle. In general, a more frequent drain cycle is required as the water hardness level rises. The drain cycle setting does not affect the AFEC system.
	Drain1 to 6 [1]			
	CycleCount:	0	*	Displays the total cycle count of the drain valve.
Command	Request:	None	None, ResetAlarms, Drain, ResetServCnt	Perform one of the following actions for the humidifier: reset warning alarms, initiate a drain cycle, reset service counters.
Diagnostic	DiagState:	* (Off, On)	Displays the diagnostic state	Set the status of the diagnostic state.
	DiagCmd:	* (Spray, Drain)	Displays the diagnostic command	Set the status of the diagnostic command.
	DiagPeriod:	* (min: 1min, max: 60min)	Displays the maximum diagnostic time to remain active	Set the value for the diagnostic period.
	DiagTimer:	* (min: 0sec, max: 3600sec)	Displays the remaining diagnostic time to remain active	Set the value of the diagnostic timer.
	Stage1Enable:	* (No, Yes)	Displays whether diagnostic stage 1 is active	Set the status of the stage 1 diagnostic enable.
	Stage2Enable:	* (No, Yes)	Displays whether diagnostic stage 2 is active	Set the status of the stage 2 diagnostic enable.
	Stage3Enable:	* (No, Yes)	Displays whether diagnostic stage 3 is active	Set the status of the stage 3 diagnostic enable.
	Stage4Enable:	* (No, Yes)	Displays whether diagnostic stage 4 is active	Set the status of the stage 4 diagnostic enable.
	Stage5Enable:	* (No, Yes)	Displays whether diagnostic stage 5 is active	Set the status of the stage 5 diagnostic enable.
	Stage6Enable:	* (No, Yes)	Displays whether diagnostic stage 6 is active	Set the status of the stage 6 diagnostic enable.



Menu - Installation [Level 4 - Requires level 4 (or higher) password in order to access]

Sub-Menu	Setting	Default	Range (* indicates no configuration; display only)	Description/Notes
Quick Config	ZoneA to D [1]:			
	StgOpenDelay:	0	min: 0, max: 30	Set the value of the stage open delay.
	Stage1 to 6 [6]:			
	Capacity:	500l/h	min:0l/h, max: 3000l/h	Set the value of the capacity.
	Zone:	ZoneA	ZoneA, ZoneB, ZoneC, ZoneD, ZoneE, ZoneF	Select the zone.
	Drain:	Drain11	Drain7, Drain8, Drain9, Drain10, Drain11, Drain12	Select the drain.
	MaxOnTime:	0sec	min: 0sec, max: 1200sec	Set the maximum value of the operating time of the unit.
	PauseTime:	15sec	min: 0sec, max: 1200sec	Set the value of the pause time of the unit.
Control	DrainVolume:	10l	min: 0l, max: 9999999l	Set the volume of water that is drained from the chamber.
	ControlProfile:	ExternAnalog	ExternAnalog, ExternNetwork, InternAnalog, InternNetwork, TRUB, Custom	Select a preconfigured control mode profile for the modulating humidity demand. Select the <i>Custom</i> option to configure individual settings. (Network option only applicable for BACnet models.)
	ModHlProfile:	Disabled	Disabled, ExternAnalog, ExternNetwork, InternAnalog, InternNetwork, Custom	Select a preconfigured control mode profile for the modulating high limit demand. Select the <i>Custom</i> option to configure individual settings. (Network option only applicable for BACnet models.)
	UnitControl [4]			
	NtwkTimeout:	900sec	min: 1sec, max: 900sec	Define the amount of time the humidifier may attempt to connect to the BACnet or Modbus network before it stops operating due to a communication error. (Only appears if there is a single zone and ControlProfile and ModHlProfile are set to InternNetwork or ExternNetwork.)
	DemandSrc:	None	None, ControllInput, HumRoomDemand, Network, TempRoomDemand	Select the humidity control demand source for modulating humidifiers. (Network option only applicable for BACnet models.)
	HighLimitSrc:	None	None, ControllInput, RHSupplyHlDemand, Network, TempSupplyHlDemand	Select the humidity control high limit source for modulating humidifiers. (Network option only applicable for BACnet models.)
	BinDemandSrc:	None	None, BinaryExtDemand	Select the humidity control demand source for On/Off humidifiers.
	RoomTempDemandLoop [6]			
	PropGain:	20.0	min: 1.0, max: 200.0	Set the value of the room demand proportional gain.
	ITime:	0.0sec	min: 0.0sec, max: 900.0sec	Set the value of the room demand integral time.
	DTime:	0.0sec	min: 0.0sec, max: 60.0sec	Set the value of the room demand derivative time.
PropBand:	5.0%	min: 1.0%, max: 100.0%	Set the value of the room demand proportional band.	
TempSrc:	None	None, TempRoom, Network, HRL	Select the reading source for the room temperature demand. (Network option only applicable for BACnet models.)	
StptSrc:	None	None, Internal, ControllInput	Select the room demand setpoint source.	
TempSupplyHlLoop [6]				
PropGain:	10.0	min: 1.0, max: 200.0	Set the value of the supply high limit demand proportional gain.	



Control	IntgrlTime:	0.0sec	min: 0.0sec, max: 900.0sec	Set the value of the supply high limit demand integral time.	
	DrvvtvTime:	0.0sec	min: 0.0sec, max: 60.0sec	Set the value of the supply high limit demand derivative time.	
	ProbBand:	10.0%	min: 1.0%, max: 100.0%	Set the value of the supply high limit demand proportional band.	
	TempSrc:	None	None, SupplyHLTemp, Network	Select the reading source for the supply high limit temperature demand. (Network option only applicable for BACnet models.)	
	StpntSrc:	None	None, Internal, ControllInput	Select the supply high limit demand setpoint source.	
	RoomRHDemandLoop [6]				Only appears if ControlProfile is set to an internal control mode and DemandSrc is set to HumRoomDemand.
	PropGain:	20.0	min: 1.0, max: 200.0	Set the value of the room demand proportional gain.	
	ITime:	0.0sec	min: 0.0sec, max: 900.0sec	Set the value of the room demand integral time.	
	DTime:	0.0sec	min: 0.0sec, max: 60.0sec	Set the value of the room demand derivative time.	
	PropBand:	5.0%	min: 1.0%, max: 100.0%	Set the value of the room demand proportional band.	
	RHSrc:	None	None, RoomRH, Network, HRL	Select the reading source for the room humidity demand. (Network option only applicable for BACnet models.)	
	StpntSrc:	None	None, Internal, ControllInput	Select the room demand setpoint source.	
	RHSupplyHLLoop [6]				Only appears if ModHLProfile is set to an internal control mode and HighLimitSrc is set to RHSupplyHLDemand.
	PropGain:	10.0	min: 1.0, max: 200.0	Set the value of the supply high limit demand proportional gain.	
	IntgrlTime:	0.0sec	min: 0.0sec, max: 900.0sec	Set the value of the supply high limit demand integral time.	
	DrvvtvTime:	0.0sec	min: 0.0sec, max: 60.0sec	Set the value of the supply high limit demand derivative time.	
	ProbBand:	10.0%	min: 1.0%, max: 100.0%	Set the value of the supply high limit demand proportional band.	
	RHSrc:	None	None, SupplyHLRH, Network	Select the reading source for the supply high limit temperature demand. (Network option only applicable for BACnet models.)	
	StpntSrc:	None	None, Internal, ControllInput	Select the supply high limit demand setpoint source.	
	Physical IO	ControllInput [6]			
Signal:		0.000V	* (min: 0.000V, max: 15.000V)	Displays the value of the control demand analog input signal.	
ControllInput:		0.0%	* (min: 0.0%, max: 100.0%)	Displays the actual value of the control demand analog input.	
Min:		0.0%	min: 0.0%, max: 100.0%	Set the minimum value of the control demand analog input.	
Max:		100.0%	min: 0.0%, max: 100.0%	Set the maximum value of the control demand analog input.	
Bias:		0.0%	min: -10.0%, max: 10.0%	Set the bias value for the control demand analog input.	
SignalType:		0-10Vdc	0-10Vdc, 2-10Vdc, 4-20mA, 0-20mA	Select the signal type for the control demand analog input.	
RoomRH [6]					
Signal:		0.000V	* (min: 0.000V, max: 15.000V)	Displays the value of the room humidity analog input signal.	
RoomRH:		0.0%	* (min: 0.0%, max: 100.0%)	Displays the actual value of the room humidity analog input.	
Min:		0.0%	min: 0.0%, max: 100.0%	Set the minimum value of the room humidity analog input.	
Max:		100.0%	min: 0.0%, max: 100.0%	Set the maximum value of the room humidity analog input.	



Physical IO	Bias:	0.0%	min: -10.0%, max: 10.0%	Set the bias value for the room humidity analog input.
	SignalType:	0-10Vdc	0-10Vdc, 2-10Vdc, 4-20mA, 0-20mA	Select the signal type for the room humidity analog input.
	SupplyHLRH [6]			
	Signal:	0.000V	* (min: 0.000V, max: 15.000V)	Displays the value of the duct or supply high limit humidity analog input signal.
	SupplyHLRH:	0.0%	* (min: 0.0%, max: 100.0%)	Displays the actual value of the duct or supply high limit humidity analog input.
	Min:	0.0%	min: 0.0%, max: 100.0%	Set the minimum value of the duct or supply high limit humidity analog input.
	Max:	0.0%	min: 0.0%, max: 100.0%	Set the maximum value of the duct or supply high limit humidity analog input.
	Bias:	0.0%	min: -10.0%, max: 10.0%	Set the bias value for the duct or supply high limit humidity analog input.
	SignalType:	0-10Vdc	0-10Vdc, 2-10Vdc, 4-20mA, 0-20mA	Select the signal type for the duct or supply high limit humidity analog input.
	SupplyHLTemp [6]			
	Signal:	0.000V	* (min: 0.000V, max: 15.000V)	Displays the value of the duct or supply high limit temperature analog input signal.
	SupplyHLTemp:	68.0°F [20.0°C]	* (min: -40.0°F, max: 30-2.0°F) * [min: -40.0°C, max: 150.0°C] Units: C, F	Displays the actual value of the duct or supply high limit temperature analog input.
	Min:	32.0°F [0.0°C]	* (min: -40.0°F, max: 30-2.0°F) * [min: -40.0°C, max: 150.0°C] Units: C, F	Set the minimum value of the duct or supply high limit temperature analog input.
	Max:	104.0°F [40.0°C]	* (min: -40.0°F, max: 30-2.0°F) * [min: -40.0°C, max: 150.0°C] Units: C, F	Set the maximum value of the duct or supply high limit temperature analog input.
	Bias:	0.00Δ°F [0.00Δ°C]	min: -18.00Δ°F, max: 18.00Δ°F [min: -10.00Δ°C, max: 10.00Δ°C] Units: Δ°C, Δ°F	Set the bias value for the duct or supply high limit temperature analog input.
	SignalType:	0-10Vdc	0-10Vdc, 2-10Vdc, 4-20mA, 0-20mA	Select the signal type for the duct or supply high limit temperature analog input.
	RoomTemp [6]			
	Signal:	0.000V	* (min: 0.000V, max: 15.000V)	Displays the value of the room temperature analog input signal.
	RoomTemp:	68.0°F [20.0°C]	* (min: -40.0°F, max: 30-2.0°F) * [min: -40.0°C, max: 150.0°C] Units: C, F	Displays the actual value of the room temperature analog input.
	Min:	32.0°F [0.0°C]	* (min: -40.0°F, max: 30-2.0°F) * [min: -40.0°C, max: 150.0°C] Units: C, F	Set the minimum value of the room temperature analog input.
	Max:	104.0°F [40.0°C]	* (min: -40.0°F, max: 30-2.0°F) * [min: -40.0°C, max: 150.0°C] Units: C, F	Set the maximum value of the room temperature analog input.
	Bias:	0.00Δ°F [0.00Δ°C]	min: -18.00Δ°F, max: 18.00Δ°F [min: -10.00Δ°C, max: 10.00Δ°C] Units: Δ°C, Δ°F	Set the bias value for the room temperature analog input.
	SignalType:	0-10Vdc	0-10Vdc, 2-10Vdc, 4-20mA, 0-20mA	Select the signal type for the room temperature analog input.
	System	ResetFactory:	No	No, Yes
Extended Config	InstallationDate:	YYYY/MM/DD		Set the device installation date.
	AlarmBuzzer:	Disabled	Normal, Disabled	Select whether to enable or disable the alarm buzzer sound whenever there is a system warning. This will not affect the Status Display LED.



Extended Config	SysLogLevel:	Debug	None, Emergency, Alert, Critical, Error, Warning, Notice, Info, Debug	Select the type of information to be stored on log file. (The humidifier must be connected to an SD card.)
	CtrlSource:	Pump Board	Zone controller, Pump Board, BMS	Select the control source.
	PowerUpDrain	Off	Off, On	Select Yes to perform drain on Power Up
	CoolDrainMode	Off	Off, TimeLatch	Select the control mode for the cooling drain.
	CoolDrainTimer	30min	Min: 0min, max:60	Set the value of the cool drain timer.
	LoWatTempAlarm:	Alarm	Alarm, Warning	Select the status of the low water temperature alarm.
	ServInterval:	1000hr	min: 1000hr, max: 3000hr	Set the time of operation before the humidifier calls for servicing.
	RunWhileServiceAlarm:	Allowed	NotAllowed, Allowed	Select whether to enable the unit to continue producing steam, even when it is due for servicing. When set to <i>Allowed</i> , the unit will continue operating even when a service alarm is active.
	ZoneAMAC:	1	min: 0, max: 127	Set the value of the MAC address for zone A.
	ZoneBMAC:	2	min: 0, max: 127	Set the value of the MAC address for zone B.
	ZoneCMAC:	3	min: 0, max: 127	Set the value of the MAC address for zone C.
ZoneDMAC:	4	min: 0, max: 127	Set the value of the MAC address for zone D.	



Menu - Integration [Level 5 - Requires level 5 password in order to access]

Sub-Menu	Setting	Default	Range (* indicates no configuration; display only)	Description/Notes
Network	NtwrkOption:	BACnet	BACnet, Modbus	Select whether to connect to a BACnet MS/TP or Modbus RTU communication interface on terminal TB2 of the humidifier PCB.
	Device [4]			
	DeviceName:	-		Establish a name for the device.
	Location:	-		Establish a designated location for the unit.
	Description:	-		Establish a brief description for the unit.
	DeviceInstance:	0153001 (0x000255a9)		Define the device instance value.
	HTTPServer [1]			
	HttpServerUnits:	Imperial	Metric, Imperial	Select whether to use a metric or imperial system of units for the web server.
	BACnetServer [3]			
	Language:	English	English, French, Spanish	Select the language for the BACnet server.
	ListMode:	Integrator	Integrator, Advanced, Factory	Select the category of BACnet objects to display.
	Units:	Imperial	Metric, Imperial	Select whether to use a metric or imperial system of units for the BACnet server.
	BACnetMSTP [10]			
	MaxMaster:	127	min: 1, max: 127	Configure MaxMaster value to increase network efficiency when there are less than 127 devices on the network. For optimal efficiency, set value to the highest MAC address in the MS/TP network.
	MaxInfoFrames:	1	min: 1, max: 100	Configure the maximum number of information messages the controller may transmit, before it must pass the token to the next controller.
	AutoBaud:	Yes	No, Yes	Enable or disable automatic baud rate detection.
	BaudRate:	38400	9600, 19200, 38400, 76800	Select the baud rate for data transfer.
	MAC:	001		Set the MS/TP network MAC address.
	RxValid:	0	*	Displays information on the received communication frames for troubleshooting purposes.
	RxInvalid:	0	*	
	RxLost:	0	*	
	Tx:	0	*	Displays information on the transmitted communication frames for troubleshooting purposes.
	TxLost:	0	*	
	BACnetIP [6]			
	RxValid:	0	*	Displays information on the received communication frames for troubleshooting purposes.
	RxInvalid:	0	*	
	RxLost:	0	*	
Tx:	0	*	Displays information on the transmitted communication frames for troubleshooting purposes.	
TxLost:	0	*		
BACnetIPPort:	47808	min: 0, max: 65535	Set the User Datagram Protocol (UDP) port number. BACnet port number is set by default.	
ModbusServer [1]				
Units:	Imperial	Metric, Imperial	Select whether to use a metric or imperial system of units for the Modbus server.	



Network	ModbusRTU1In [4]			Only appears if <i>NtwrkOption</i> is set to <i>Modbus</i>.
	MAC:	1	min: 1, max: 247	Set the Modbus MAC address.
	Autobaud:	Yes	No, Yes	Enable or disable automatic baud rate detection.
	PortConfig:	No Parity, 2 Stop Bits	No Parity, 2 Stop Bits Even Parity, 1 Stop bit Odd Parity, 1 Stop bit	Select the Modbus communication port configuration.
	BaudRate:	19200	9600, 14400, 19200, 38400, 57600	Select the baud rate for data transfer.
	BACnetETH [5]			For models connected to BACnet Ethernet.
	RxValid:	0	*	Displays information on the received communication frames for troubleshooting purposes.
	RxInvalid:	0	*	
	RxLost:	0	*	
	Tx:	0	*	Displays information on the transmitted communication frames for troubleshooting purposes.
	TxLost:	0	*	
	ModbusTCPiP0In [2]			For models connected to Modbus TCP/IP.
	KeepAliveTimeOut:	5min	min: 1min, max: 1440min	Set the amount of time the communication stays open before connection is cut out, when no signal is received from the device.
	ListeningPort:	502	min: 0, max: 65535	Set the communication port number. Modbus TCP port number is set by default.
	SMTP [7]			
	SSL:	Off	Off, On	If turned to <i>On</i> , a secure socket layer will be used to encrypt the communication between the device and the email server (Port value must be set to <i>587</i> and <i>Username</i> and <i>Password</i> settings must be filled out). If turned to <i>Off</i> , the default socket will be used (use Port <i>25</i> to use server without login account or Port <i>587</i> if login details for email account have been entered).
	Port:	25	25, 587	If set to <i>25</i> , server to server email transfer is enabled (can only be used if SSL is set to <i>Off</i>). If set to <i>587</i> , client to server email transfer is enabled.
	ServerAddr:	192.168.100.100		Configure the server IP address for the email account.
	From:	<i>Current value</i>		Set the email address that will be sending the humidifier notification messages.
	To:	<i>Current value</i>		Set the email address that will be receiving the humidifier notification messages.
	Username:	<i>Current value</i>		Set the login username for the email account.
	Password:	<i>Current value</i>		Set the login password for the email account.
	Notify [3]			
	Alarm:	Off	Off, On	If turned to <i>On</i> , then the humidifier alarm messages will be sent to the email configured in the <i>SMTP</i> sub-menu.
Warning:	Off	Off, On	If turned to <i>On</i> , then the humidifier warning messages will be sent to the email configured in the <i>SMTP</i> sub-menu.	
AppMsg:	Off	Off, On	If turned to <i>On</i> , then the humidifier event messages will be sent to the email configured in the <i>SMTP</i> sub-menu.	
Communication	IPSettings[10]			
	DHCP:	Inactive	Inactive, Active	Select whether to enable Dynamic Host Configuration Protocol (DHCP) to automatically provide an IP address.



	RstIPSetting:	No	No, Yes	Select whether to restart the IP module, in order to allow recent parameter modifications to be effective.
	StaticAddress:	192.168.1.100		Configure the static IP address.
	StaticSubnetMask:	255.255.255.0		Configure the static subnet mask.
	StaticDefaultGateway:	192.168.0.100		Configure the static default gateway.
	StaticDnsServer:	192.168.10.50		Configure the static DNS server.
	ActualAddress:	<i>Current value</i>	*	Displays the actual IP address.
	ActualSubnetMask:	<i>Current value</i>	*	Displays the actual subnet mask.
	ActualDefaultGateway:	<i>Current value</i>	*	Displays the actual default gateway.
	ActualDnsServer:	<i>Current value</i>	*	Displays the actual DNS server.
	ETHSettings[1]			
	EthernetMacAdd:	<i>Current value</i>	*	Displays the MAC address of the Ethernet interface. (Only applicable if using an Ethernet connection.)

List of Alarms and Warnings

Table 13 - List of Alarms

Display	Description	Alarm Reset
For each Zones		
AirFlow (Zone A to D)	Indicates that the airflow sensor (of Zone A to D) is open. Verify that the signal from the airflow sensor is present at the controller's input on the PCB and verify wiring.	Automatic
SupplyHighLimit (Zone A to D)	Indicates that the high limit item (of Zone A to D) is open. Verify that the signal from the supply high limit sensor is present at the controller's input on the PCB and verify wiring.	Automatic
Interlock (Zone A to D)	Indicates that the interlock and the cut-out circuitry (of Zone A to D) are open. Verify that the signal from the interlock sensor is present at the controller's input on the PCB and verify wiring.	Automatic
Pump Unit Alarms		
HighLimitCutout	Indicates that the high limit cutout has been activated due to a reading that exceeds the high limit setpoint. Ensure that the high limit humidistat is operating correctly and is not located too close in proximity to the distribution apparatus.	Automatic
RelayFuse	Indicates that there is an issue with the printed circuit board fuse. Check the status of the fuse and replace it if defective.	Automatic
Airflow	Indicates that the airflow sensor is open. This fault does not trigger the alarm contact (no message will be displayed) but will prevent the SKH4 from running. Verify that the signal from the airflow sensor is present at the controller's input on the PCB and verify wiring.	Automatic
SupplyHighLimit	Indicates that the high limit item is open. Verify that the signal from the supply high limit sensor is present at the controller's input on the PCB and verify wiring.	Automatic
Interlock	Indicates that the interlock and the cut-out circuitry are open. This fault does not trigger the alarm contact (no message will be displayed) but will prevent the SKVF from running. Verify that the signal from the interlock sensor is present at the controller's input on the PCB and verify wiring.	Automatic
MemoryCard (Warning)	Indicates that the SD card has been detected, but it is not operating correctly or is non-functional. Verify the SD card and replace if defective.	Automatic
USB Device (Warning)	Indicates that the USB device has been detected, but it could not be read or is not operating correctly. Verify the functionality of the USB device and replace if defective.	Automatic
WatHiTemp	Indicates that the water temperature is above the MaxWatTemp, which causes the humidifier to exit the spray state and perform a drain in order to lower the temperature and resume operation. If the temperature is still too high, an alarm will trigger and demand a manual reset.	Manual *
WatLoTemp	Indicates that the water temperature is below the MinWatTemp, causes the humidifier to exit spray state.	Manual *
OutHiPress	Indicates that the water pressure has raised above the MaxHighPress, causes the humidifier to exit spray state.	Manual *
OutLoPress	Indicates that the water pressure has fallen below the MinHighPress, causes the humidifier to exit spray state.	Manual *
InLowPress	Indicates that the low-pressure switch is open for the time greater than WaterInletPressDelay during the operation of the humidifier.	Automatic
WaterLeak	Indicates that a water leak has been detected. Verify the water line for signs of leaks and ensure that all piping and water connections have been properly installed and secured.	Manual *
Config	Indicates that the configuration is not valid in factory settings. For example, at least one stage is not enabled, or a drain stage is not enabled.	Automatic
NtwkCtrlState	Indicates that the communication attempt to the BMS server has exceeded the delay defined by the <i>NtwkTimeout</i> setting. Verify the wiring between the humidifier and the BACnet or Modbus network and ensure proper connection. (Only applicable for units connected to BACnet or Modbus).	Manual *
ServiceDue	Indicates that the due date for servicing the SKH4 unit has arrived. See Servicing and Maintenance section on page 55 for details.	Manual ***

* Use the ResetAlarms function in the Request setting (see page 36).

** Use the ResetServCnt function in the Request setting (see page 36).

Distribution Installation

Refer to Neptronic's guideline in Space Mist Humidification Design for additional information and recommendations on the design of a hydraulic distribution network. Consult the respective design guides for each of the three distribution techniques.

Spraying in Space (Standard)

An in-space hydraulic network is made up of piping that starts at the stage valve and goes towards the drain valve. Along this run of pipe, single nozzles, or fan-assisted distributors (optional), can be placed in order to spray directly into the area.

- Plan a location that is easy to access and permits easy inspection and servicing of the nozzles.
- The hose used must be stainless steel tubing or flexible nylon hose. It must be appropriately sized for the flow and the in-line pressure.
- Hoses must be maintained/attached securely and must not move when pressure is applied.
- Do not install the ramp and nozzle where failure of the system could cause damage to the building structure or to other expensive equipment.
- Ensure that the mist is not directed and or at risk of condensing on any equipment.

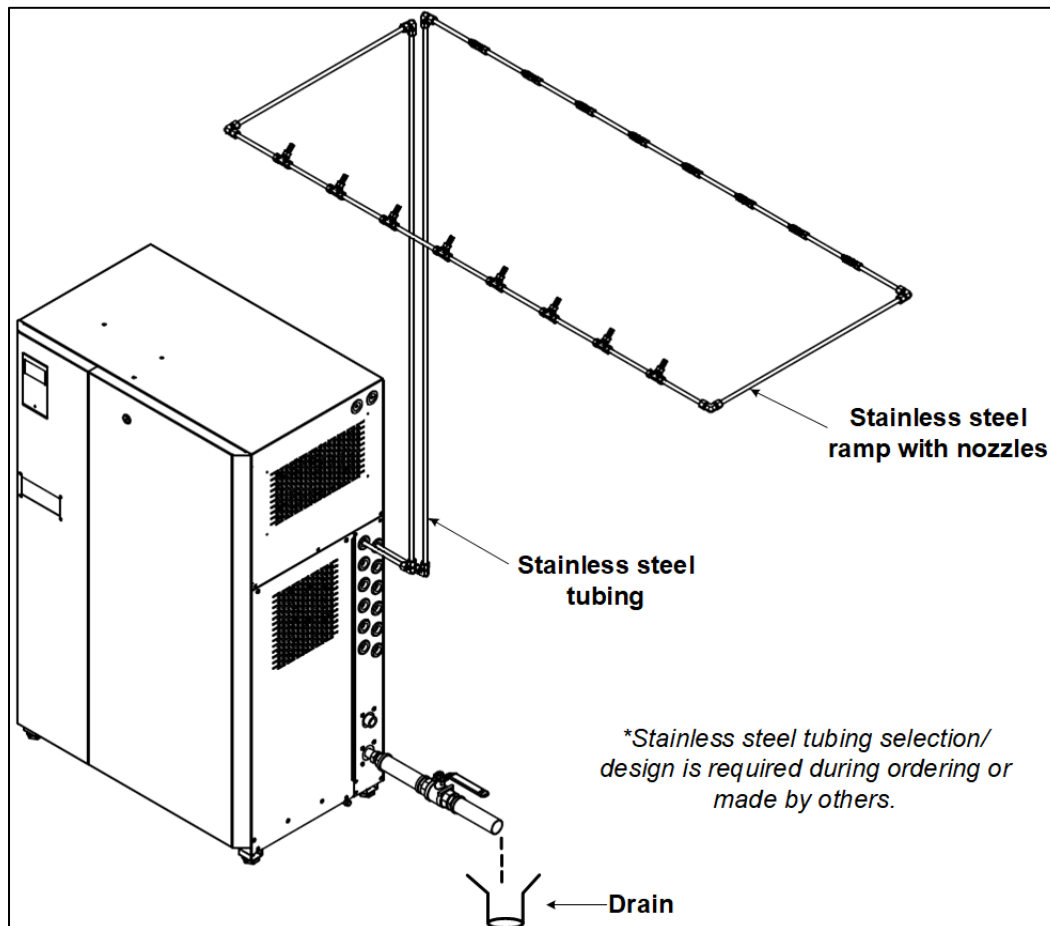

Illustration 17 - Typical Installation with Rigid Nozzle Ramp

High-pressure water outlets use a 3/8" (DN10) or 1/2" (DN15) flexible high-pressure nylon hose (available upon request) connected to a push-to-connect fittings (available upon request) with the respective stage and drain valves.

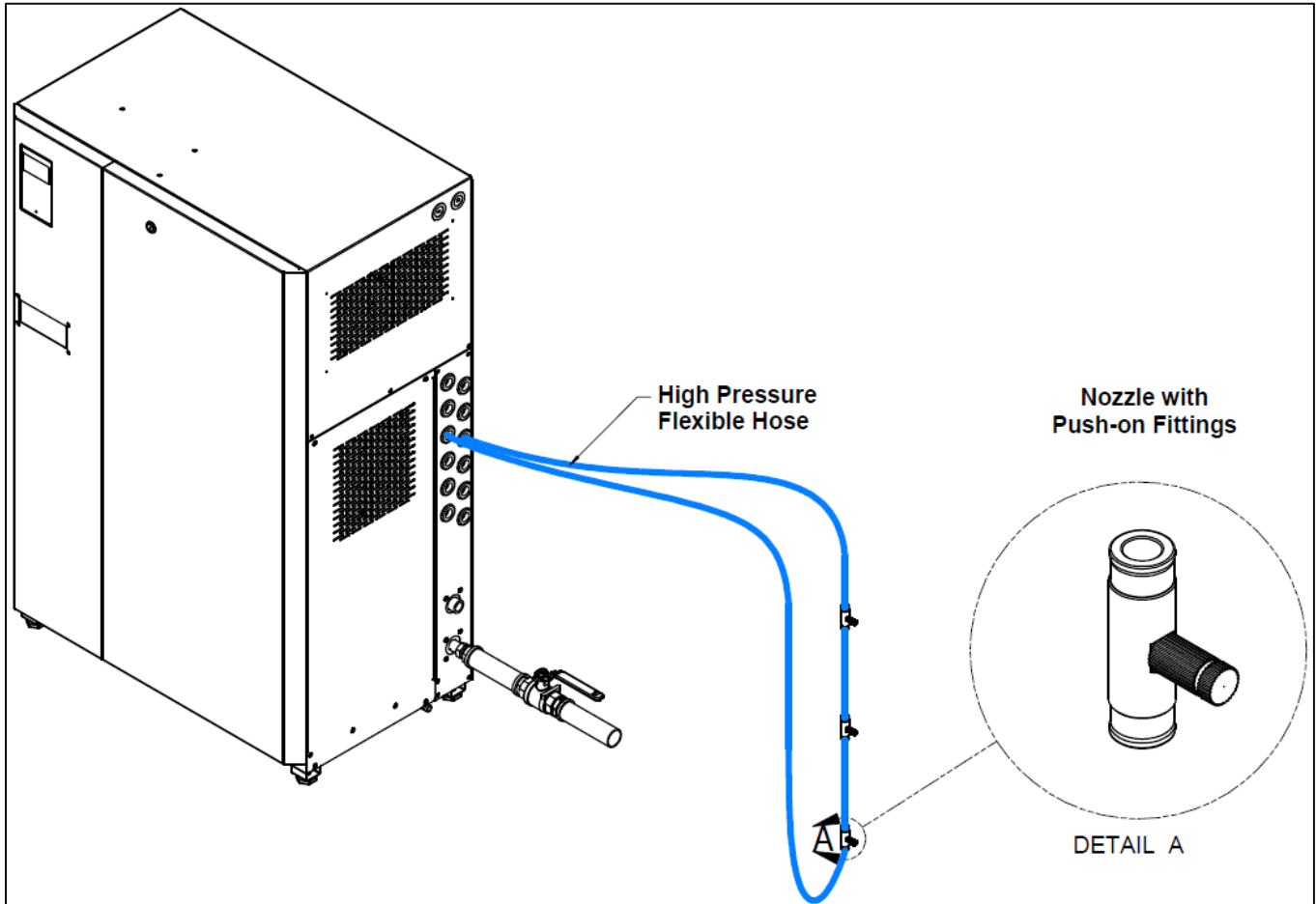

Illustration 18 - Typical Installation with Flexible Nylon Hose

Spraying in Space with Fan-Assisted Distributors

- Plan a location that is easy to access and permits an easy inspection and servicing.
- Do not install the distributors where failure of the system could cause damage to the building structure or to other expensive equipment.
- Ensure that the mist is not directed and condensed on any equipment, especially the electrical equipment.
- Respect clearances for absorption specified in the fan assisted design guide.

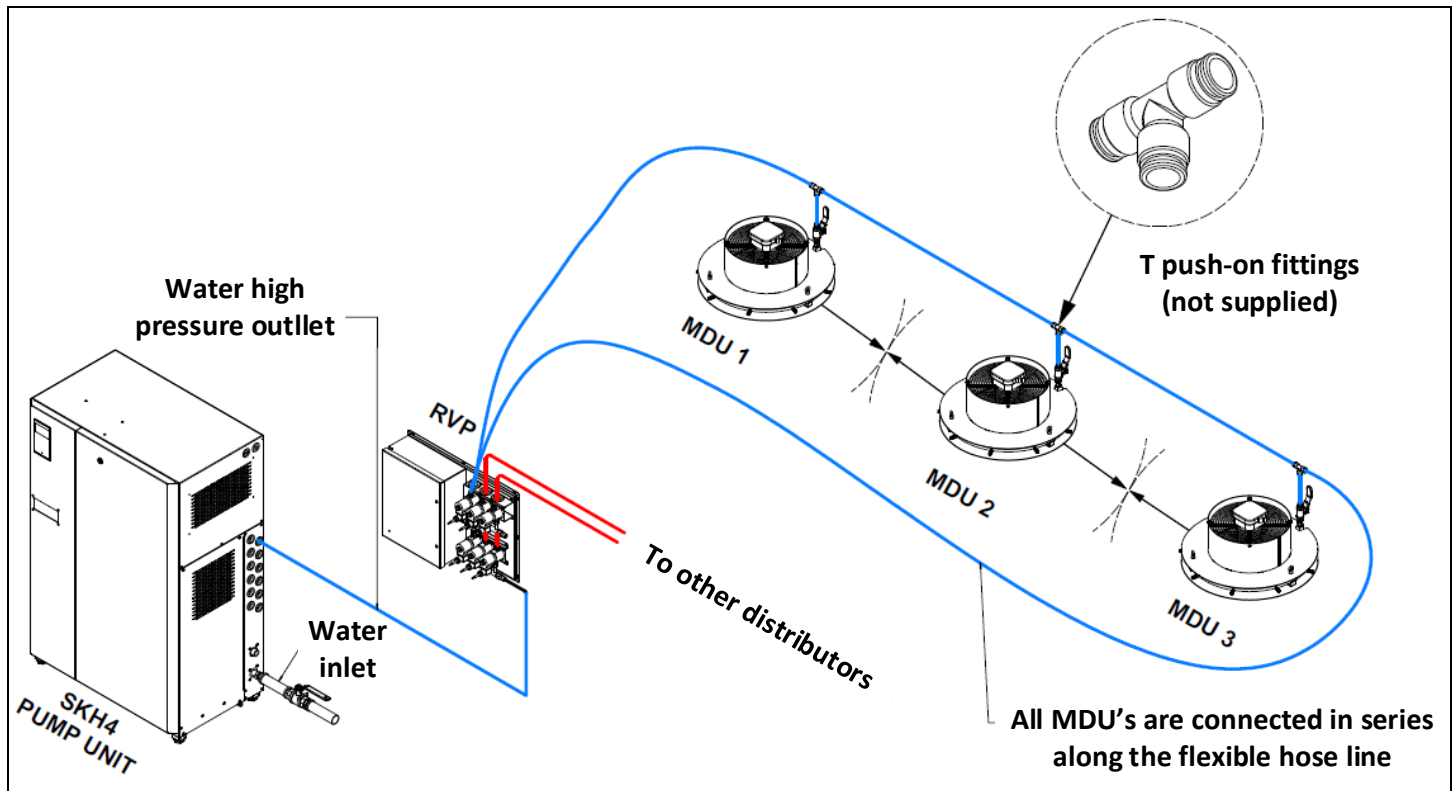

Illustration 19 - Fan-Assisted Distributors Typical Installation

Ceiling Installation

To install the MDU to the ceiling, connect two metallic suspension cables (not supplied) to the three rings. Verify the strength of the cables and ensure that they can support the weight of the distributor (see table) before commencing installation.

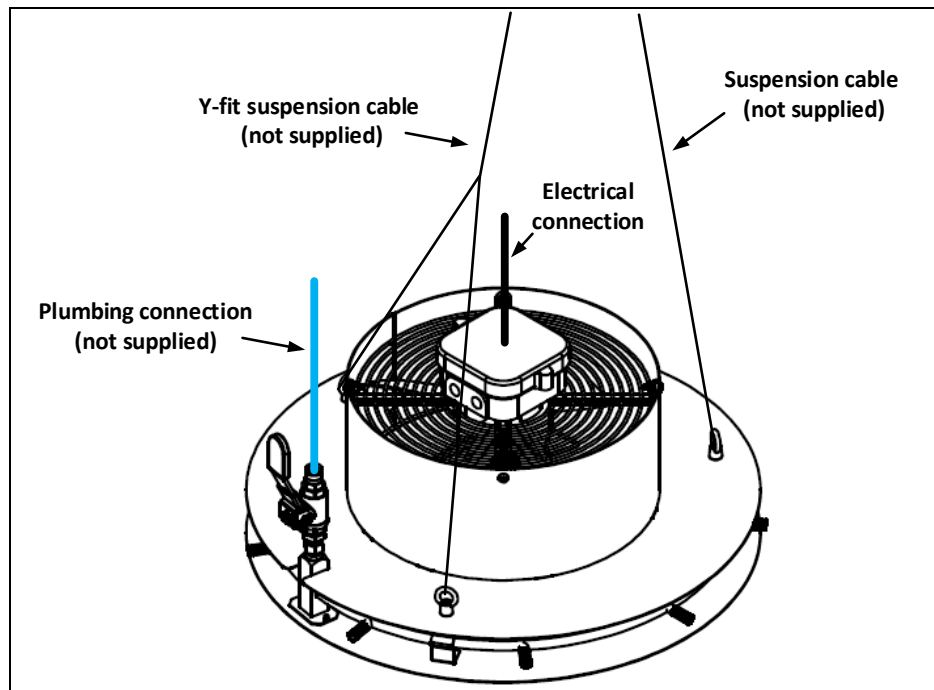

Illustration 20 - ADU Ceiling Installation

Wall Installation

To install the distributor to the wall, fasten with screws (not supplied) to a suitable location:

- Check the solidity of the chosen support or wall (brick, concrete, or stud partition wall) on which the distributor remote panel will be mounted.
- Drill holes matching the hole of the support into the support or wall (anchors not supplied):
- Ensure that the hole dimensions (diameter and depth) adhere to the recommendations of the chosen anchors. If required, you can install and then bolt the anchors.
- Affix screws (not supplied) with a minimum diameter of 0.23" (6mm) to all fixation points.
- Adjust the positioning of the distributors and lock in place using the fixation hardware on the distributors.



Fan assisted Power Supply Connections

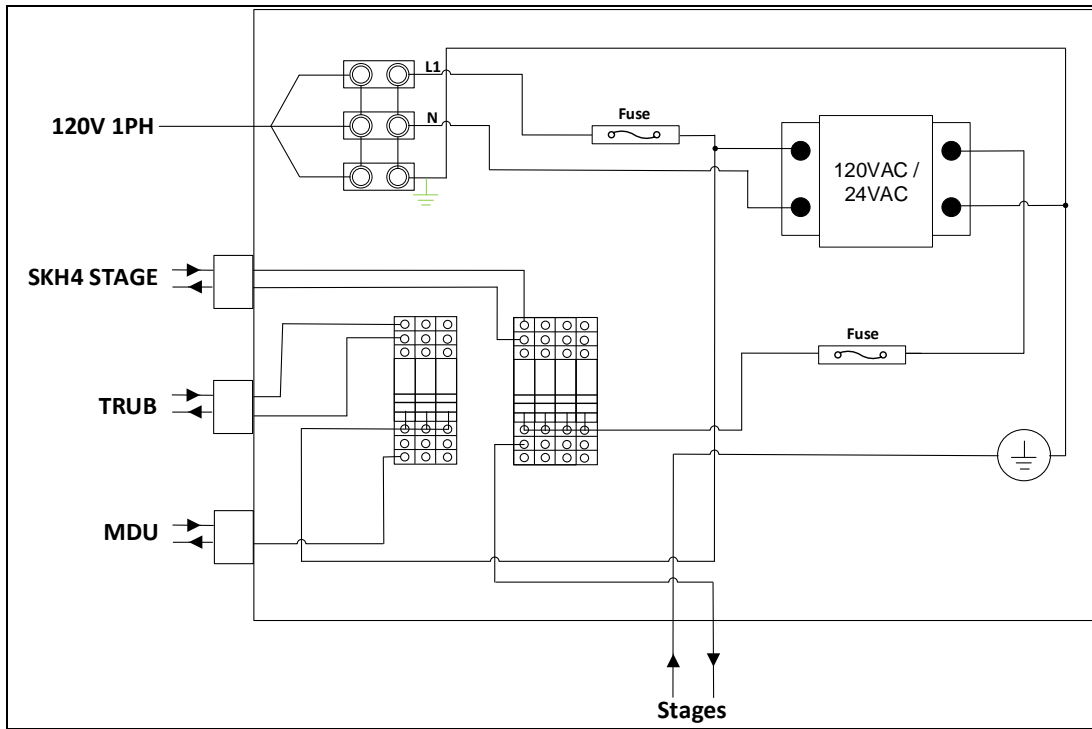

Illustration 21 - 120V Power supply Connections

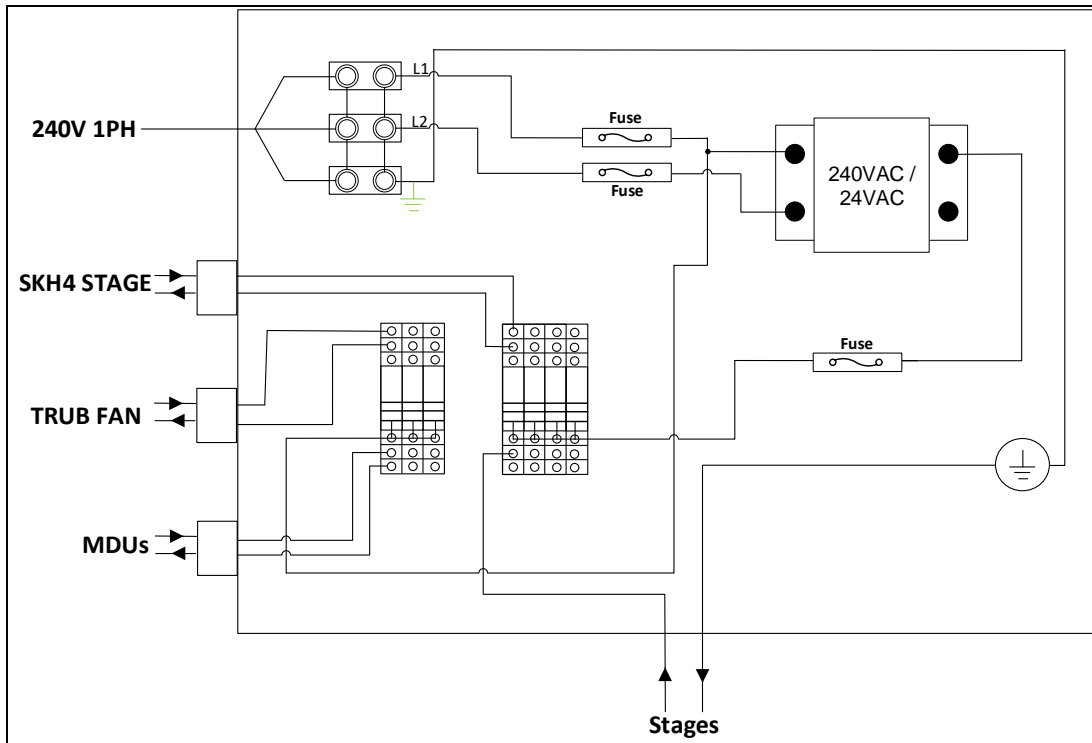

Illustration 22 - 240V Power supply Connections

Spraying in Duct

- Plan a location that is easy to access and permits an easy inspection and servicing of the nozzle.
- Do not install the ramp and nozzle where failure of the system could cause damage to the building structure or to other expensive equipment.
- Ensure that the mist is not directed and condensed on any electrical equipment.
- Construct the drainpipe in such a way that there is no water accumulation and stagnation.
- The wet section of the duct must be constructed in stainless steel in order to prevent corrosion and must be equipped with a pan drain outlet in order to remove any water residue. See guide for more details.

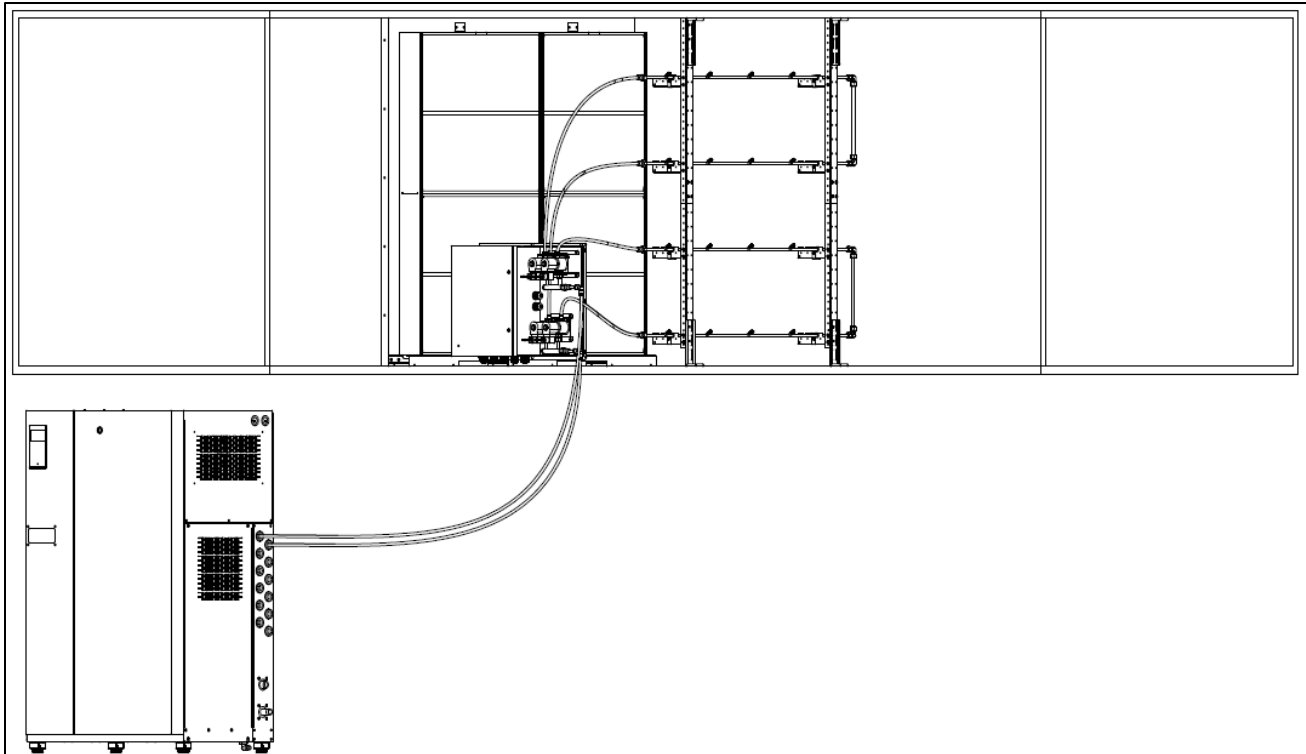

Illustration 23 - In Duct Distribution

Optional – Remote Valve Panel (RVP)



WARNING: Risk of electric shock. Disconnect the appliance from the electric supply before commencing installation.

An optional remote panel serves two purposes. The first is to allow a connection for the fan-assisted distributors and a connection to the control wire to start the fan before the spraying action. The second is to allow for valves to be placed outside of the enclosure, to minimize the length of piping during installation. Control signal wires are connected from the pump unit's PCB to the relays in this electrical panel in order to remotely activate the solenoid valves.

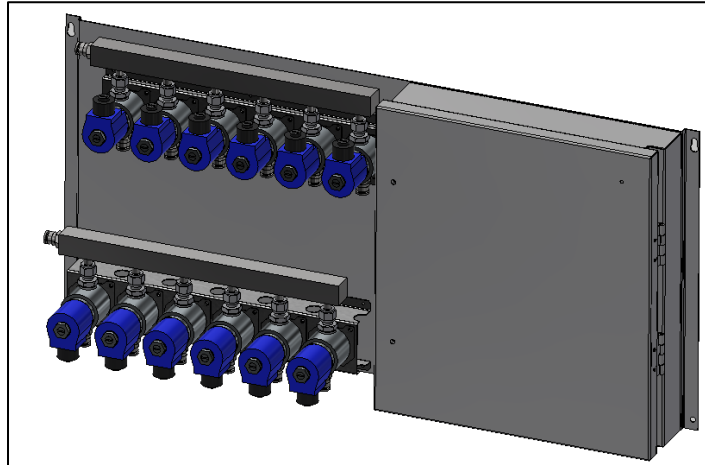

Illustration 24 - Remote Valve Panel

RVP Dimensions

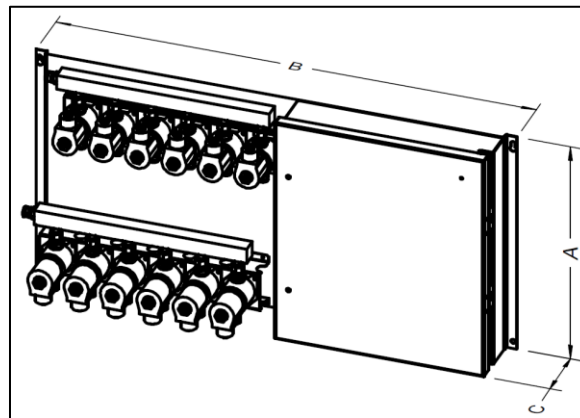

Illustration 25 - RVP Dimensions

Table 14 – Remote Valve Panel (RVP) Dimensions & Weight

Model	Dimensions in (mm)		
	A	B	C
RVP 0	15 (381)	15 (381)	4 (101)
RVP 2		20 (508)	
RVP 4		25 (635)	
RVP 6		30 (762)	

Location

- Plan a location that is easy to access and permits an easy inspection and servicing of the RVP panel.
- Do not install the RVP panel where failure of the valve could cause damage to the building structure or to other expensive equipment.
- Ensure that the location is ventilated appropriately and that the ambient temperature is less than 86°F (30°C).

Positioning

- There is no minimum clearance required for safety purposes.
- Provide a minimum clearance of 31" (0.80 m) in front of the RVP panel, in order to allow access to the connections and servicing.
- It is recommended (but not mandatory) to allow some clearances on both sides and on the top of the RVP panel for ease of service.

Picture of RVP with clearances and keyhole wallmounting

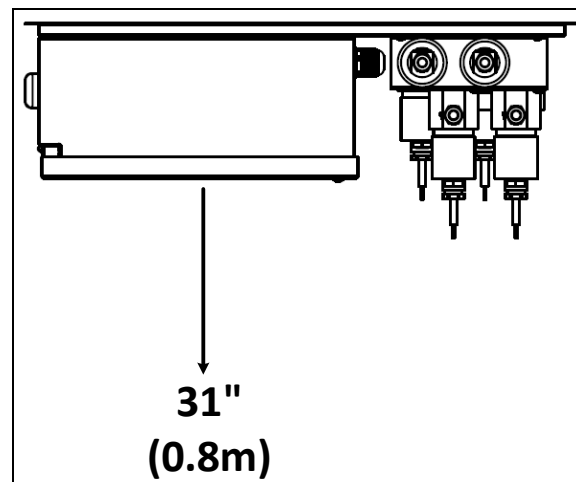

Illustration 26 - RVP Clearance

Wall Mounting

- Use the keyholes located on the back of the RVP panel.
- Check the solidity of the chosen support or wall (brick, concrete, or stud partition wall) on which RVP panel is mounted.
- Drill holes for the upper anchors (holes with keyholes) into the support or wall, as per dimensions specified in the below table (anchors not supplied):
- Ensure that the hole dimensions (diameter and depth) adhere to the recommendations of the chosen anchors. If required, you can install and then bolt the anchors.
- Affix two screws (not supplied) with a minimum diameter of 0.23" (6mm) to the top keyholes. Leave a clearance between the head screws and the wall to permit the mounting of the RVP panel.
- Hang the RVP panel on the two screws. Based on the size and weight of the RVP panel, you may need the assistance of another person.
- Tighten the screws to secure the RVP panel once it is positioned on the upper screws.
- Install and secure two screws (not supplied) onto the bottom screw holes of the RVP panel.

Start-Up Procedure

Once the installation is complete, follow this start-up procedure in order to ensure that the SKH4 High-Pressure Atomizer is ready for normal operation. We strictly recommend following this procedure in order to avoid any anomaly resulting from inaccurate installation of the components.



Initial verification and start-up must be carried out by suitably qualified personnel.

Initial Verification

- | | |
|-------------------|--|
| Clearance | 1. Ensure that the humidifier cabinet is installed in a location where it can be serviced correctly. <input type="checkbox"/> |
| | 2. Ensure that the pump station is installed in a temperature-controlled environment of less than 86°F (30°C). Verify that the pump station is fixed securely to the ground and that it remains stable. <input type="checkbox"/> |
| Mechanical | 3. If an in-duct spray system is used, ensure that the nozzle rack assembly is correctly installed within the AHU. <input type="checkbox"/> |
| | 4. If an MDU or ADU is used for in-space spray distribution, ensure that it is correctly installed and secured onto the ceiling. <input type="checkbox"/> |
| Hydraulic | 5. Verify that the pump station water connections are installed properly: <ul style="list-style-type: none"> a) Ensure that water is supplied to the humidifier and that an isolation valve is installed on the water line. With the water isolation valve turned on, verify that there are no apparent leaks. <input type="checkbox"/> b) Ensure that the pan drain outlet is properly connected to a flexible hose and that it is directed towards an open drain. Verify that the water drainage is not obstructed. <input type="checkbox"/> c) If using a SS pump, bleed the pump of air before starting the unit. <input type="checkbox"/> |
| | 6. Verify that the zone hydraulic connections are installed properly: <ul style="list-style-type: none"> a) If an in-duct spray system is used, ensure that all nozzle ramps are properly connected and assembled onto the rack assembly. <input type="checkbox"/> b) If a standard in-space spray distribution system is used, ensure that all nozzles within the ramp have been connected in series and that they are properly secured. <input type="checkbox"/> c) If an in-space fan-assisted spray distribution system is used, ensure that all units are connected in series and that they are properly secured. <input type="checkbox"/> d) Ensure that isolation valves are opened on all the fan-assisted distributors <input type="checkbox"/> |
| Electrical | 7. Verify that the power supply (voltage) conforms to the appliance name plate on the side of the humidifier. <input type="checkbox"/> |
| | 8. Ensure that the Interlock is properly connected to the controller. If Interlock is not used, verify that a jumper is connected between terminals TB3 1&4. <input type="checkbox"/> |
| | 9. If a room or duct humidistat is used, verify that it is fixed securely to the wall or duct and to the pump unit, respectively, and ensure that it is properly connected to the controller. Verify that the setpoints and the address are properly adjusted. <input type="checkbox"/> |
| | 10. If a TRUB is used, verify that it is fixed securely to a support or wall located within the desired zone and ensure that it is properly connected to the pump unit. Verify that the setpoints are properly adjusted. Refer to the TRUB documentation for more information. <input type="checkbox"/> |

Diagnostic mode

If required, a diagnostic mode is accessible through the Service menu, the diagnostic mode allows manual activation and override of the SKH4. It's possible to activate each stage without any demand to the pump. This allows for inspection, purging the air out of the line and validation of operation of a particular stage.



Alarms and interlocks coming from zone(s) are bypassed while manual override is active.

Enter the mode from the Service, Diagnostic mode. The function allows to select the action to drain or to pressurize the stage(s) selected below, and then to turn the action on or off.

First, select the command type (Spray or Drain), set desired time for test, and enable or disable the desired stage(s) manually. To turn on the action, change the DiagState to ON.

Going out of the menu, changing Command type or the end of Period will turn the State back to Off. The exiting of the diagnostic state sends the SKH4 to its regular Off state.

Servicing and Maintenance



This humidifier must be installed, operated, and maintained by suitably qualified personnel and in accordance with this manual.



Before performing any servicing on the unit, turn off the disconnect and use Lock Out procedure.

Damage to the other parts of the SKH4 system are most often caused by particles or debris in the water. Ensure constant quality of water supplied to the unit. Inspection of parts of the pump unit and of the network of distribution is necessary to ensure the proper function of the system and to prevent leakage.

Preventative Maintenance

Component	How Often is Maintenance Required	Maintenance Steps
Pressure manometers	Every 2000 hours	- Inspect the high pressure and low pressure manometers in front of the unit and verify that the pressures match the ones indicated under the <i>pressure</i> settings in the menu Menu - General [Level 1 - No password required] page 31. - If the pressure is not the same, replace the high pressure or low pressure manometer.
Hydraulic pipes		- With the unit turned on, check for leaks coming from the water supply inlet, high-pressure outlet and zone distribution piping. - If a leak is found, replace the leaking pipes or fittings.
Nozzles		- With the unit turned on, verify if the nozzles are blocked during normal operation. - If the nozzles are blocked, disassemble them for inspection: a) If blocked by large particles, remove the particles and reassemble the nozzles. b) If blocked by the presence of mineral deposit or scale, replace the nozzles.
Distributor fan (<i>option</i>)		- With the unit turned on, verify whether the fan is operating correctly and without any problems. - Replace the motor fan if faulty operation is observed.
Droplet separator – Duct Distributor (<i>option</i>)	Every 2500 hours (up to 5000 hours depending on condition)	- Verify that the droplet separator is not being obstructed by scale. - If there is scale, proceed to de-scale the droplet separator as per the steps described in the De-scaling the Droplet Separator section.

Preventive Maintenance (continued)

Component	How Often Maintenance is Required	Maintenance Steps
Stainless Steel pump (SKH4-XXXXS models)	Every week	<p><u>Visual inspection</u> for the absence of water leaks. Verify that nominal pressure is normal for your system. Loss of pressure can be an indication that the distribution network needs servicing or the pump. Pump noise that degrades is also an indicator that maintenance is required.</p>
	Every 8000 hours	<p>Removal of the pump to inspect the parts and replacing the O-ring is necessary to ensure the life of the pump. A replacement seal kit is available from the Neptronic factory. Contact customer service for the kit and detailed instructions.</p> <p><u>Disassembling and inspecting the pump:</u></p> <ul style="list-style-type: none"> - Cut off the water supply and disconnect the hoses from the inlet and outlet of the pump. - Unscrew the fasteners of the bell housing from the motor and remove the pump from the bell housing. - Perform the disassembly of the pump on a clean work bench in order to prevent any contamination with particles or chemicals. - Follow the guide available from Neptronic. - Inspect all parts for wear or scratches <p><u>Reassembly</u></p> <ul style="list-style-type: none"> - Lubricate all threads with a PTFE type lubricant. - At reassembly, lubricate all parts with clean filtered water. - Follow the guide for the reassembly and replacement of the seals with the parts from the kit. - Fastened to the bell housing, add the coupling, and place it back onto the motor, ensuring that the couplings mesh together. <p><u>Restarting the unit:</u></p> <ul style="list-style-type: none"> - Follow the steps outlined in the start-up section to restart the humidifier and ensure that it is operating correctly before resuming normal operation.
Brass pump (SKH4-XXXXB models)	Every week	<p><u>Visual inspection</u> of the oil level through the sight glass, ensuring absence of water mixed in the oil and absence of any oil leaks. Ensure that nominal pressure is normal for your system. Loss of pressure can be an indication that the distribution network needs servicing or the pump. Pump noise that degrades is also an indicator that maintenance is required.</p>
	Every 500 hours	<p><u>Oil change (~10min)</u></p> <ul style="list-style-type: none"> - Unscrew both caps with a pan underneath the pump in order to catch the oil. Inspect the oil for debris or particles in it; if found, it can be an indicator of damage to the pump. - Screw back the bottom cap and fill the oil reservoir to at least the middle of the red dot. - Screw back the top cap. - Dispose of the oil properly according to the local regulations.
	Every 2500 hours (up to 8000 hours depending on condition)	<p><u>Seal replacement (~60min)</u></p> <ul style="list-style-type: none"> - Refer to the detailed guide provided with the seal replacement kit from Neptronic.
	Every 5000 hours (up to 16000 hours depending on condition)	<p><u>Valve replacement (~60min)</u></p> <ul style="list-style-type: none"> - Refer to the detailed guide provided with the seal replacement kit from Neptronic

Nozzle Cleaning

The SKH4 nozzles will eventually get clogged by the accumulation of scale and/or particles inside the tubing, resulting in a blocked or leaking nozzle which will require cleaning or replacement of the nozzle.

- A blockage of the nozzle will require cleaning the nose (#1) and plunger (#3).
- A leakage will require the cleaning of the plastic ball (#4) and the seat inside of the body (#5).
- Parts (#7,8 and 9) are optional PE filters and must be replaced whenever clogged.
- The nozzles can be cleaned using light descaling agents such as acetic acid (vinegar) and a plastic brush.

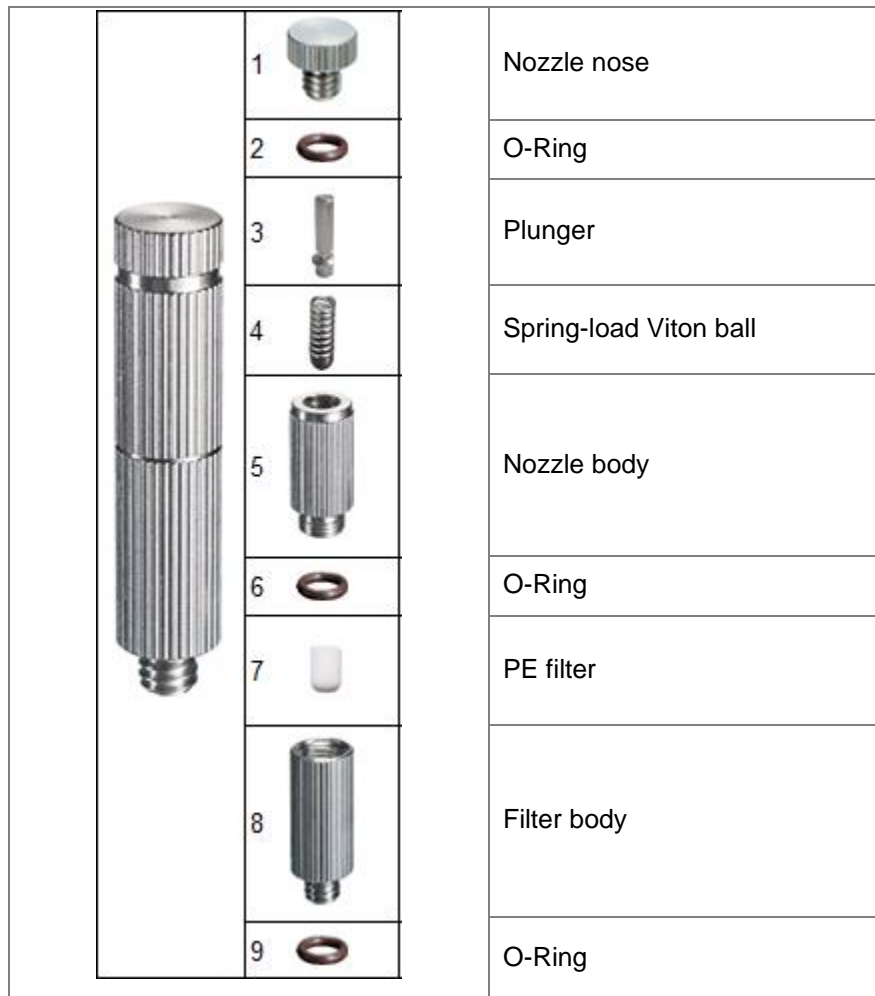

Illustration 27 - Nozzle Parts List

De-scaling the Droplet Separator

Step 1 - Preparation

- Refer to the manufacturer's recommendations for concentrations to apply and the method of preparation of the solution. When using white vinegar (acetic acid), do not exceed a concentration of 250-260 ppm when descaling the media.
- Ensure that the air system (central air or ventilation system) is stopped.
- Ensure that the SKH4 is stopped.



CAUTION: When working with de-scaling solutions, always wear appropriate personal protective clothing, protective gloves, and eye protection.

Step 2 - Dismantle the Droplet Separator

- Turn off and isolate electrical supplies to the unit.
- Remove all media cassettes.

Step 3 - Prepare the De-scaling Solution



CAUTION: Risk of emanation of gas irritants, ensure to perform these tasks in a well-ventilated area. It is recommended to perform the following steps outside.

- Mix the de-scaling solution according to the manufacturer's recommendations.
- Use a clean container of a suitable size to completely immerse each media cassette.
- Ensure that a second clean container of a suitable size is within reach and has been filled with clean, clear water to immerse each cassette after de-scaling.

Step 4 - Remove Scale from Individual Cassettes

- Using a soft brush, lightly brush any loose scale from the surface of the media.
- Lower the individual cassettes into the de-scaling solution.
- Keep each matrix cassette in the solution until the reaction between the calcium on the matrix and the de-scaling solution is complete.



Note: The effect of the de-scaling solution will vary depending on the condition of the media's material. For an improved effect, the above process may have to be repeated.

- Clean and if necessary, apply the de-scaling solution on all parts which are covered with scale.

Step 5 - Rinse

- Lift the individual cassettes out of the acid solution, while allowing any excess de-scaling solution to drip, and directly submerge them into the clean water container.
- If necessary, rinse a second time while profusely wetting the media.

Step 6 - Re-assemble and Restart

- Replace the media cassettes and media frames on the droplet separator.
- Reconnect the power supply.



neptronic®

400 Lebeau blvd, Montreal, Qc, H4N 1R6, Canada

www.neptronic.com

Toll-free in North America: 1-800-361-2308

Tel.: (514) 333-1433

Fax: (514) 333-3163

Customer service fax: (514) 333-1091

Monday to Friday: 8:00am to 5:00pm (Eastern Time)