

SKG4-Gas Fired Humidifier Brochure



neptronic[®]

SKG4 GAS FIRED HUMIDIFIER

The SKG4 gas fired humidifier generates mineral free, odorless, sterile steam by using the power of natural gas or propane. Cost of operation and its carbon footprint is much lower than electric humidifiers with equivalent control accuracy.

Advantages

- Steam capacity from 50 to 400kg/hr
- Turn down ratio of 10:1 (minimum) up to 40:1 (maximum)
- Functions with Tap, RO or DI water
- Combustion efficiency: 83% to 87%
- Easy servicing: clean and re-install within minutes
- Waste water drained below 60°C
- Smallest footprint in the industry
- Patented Anti-Foaming Energy Conservation (AFEC) System
- Advanced controller with multiple connectivity options
- Self-adjusting burner for altitude compensation

Typical Applications

When natural gas or propane or LPG is available on site, the SKG4 gas fired humidifier is ideal for capacities from 50-400kg/hr. Typical applications for SKG4 humidifiers include:

Hospitals/Institutions



Paint Booths



Clean Rooms



Laboratories



Commercial



Typical Installation

The SKG4 gas fired humidifier is designed to distribute steam into a duct or AHU. Common water supply inlet, gas supply inlet, drain outlets and flue outlet can be located either on the right or left hand side of the SKG4. Steam outlets are located on top of each module. Air inlet can be through the front door with natural ventilation or from top of each module if direct combustion air (sealed combustion) option is selected.

If flue pipe installation or air supply is an issue, the optional ETL certified outdoor enclosure is an ideal choice.

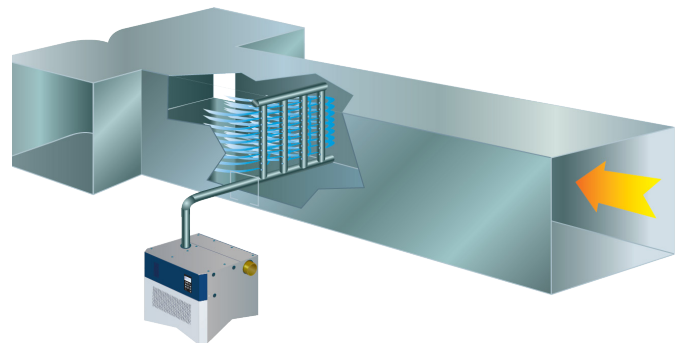

System Overview

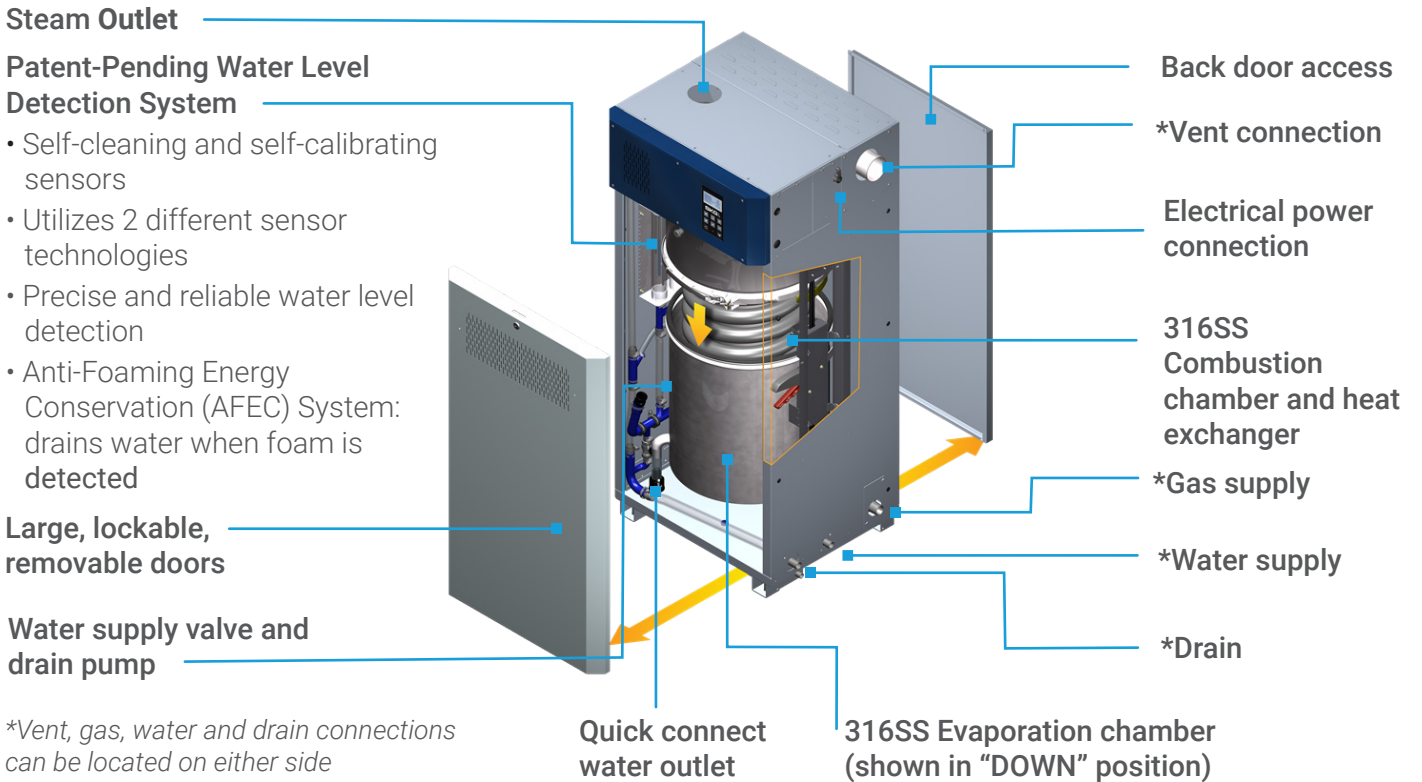

Maintenance

4 Easy Steps!

1 Disconnect the drain water connection

2 Disengage the band clamp

3 Lower the evaporation chamber

4 Remove chamber for scale cleaning



Steam Distribution Systems



Multi-Steam™ SD
For absorption distance of less than 900mm

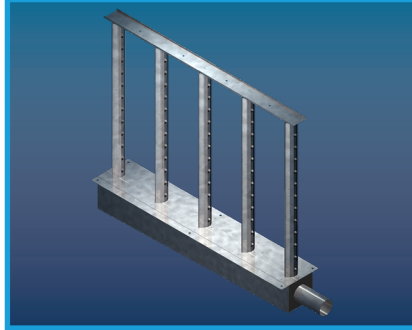

Multi-Steam™ HD
High efficiency steam distributor (channel and header) with steam ejector eyelets



S.A.M.E2
For absorption distance of less than 1500mm

Outdoor Enclosure

- Hinged doors provide full access (serviceability) from the front, back and top of unit
- Fully insulated and constructed from heavy duty steel
- Stainless steel bottom drip pan
- Zinc primer and polyurethane powder coating for resistance against scratches and corrosion
- Built-in anti-freeze and overheat protection
- Easy installation on a roof curb, stand or slab
- Connection can be made from side or through the roof curb



Modular Design

Flexible Solution for Indoor/Outdoor Applications

Modular design offers flexibility and convenience; each module adds up to 100kg/hr of steam capacity. With the smallest footprint in the industry, the SKG4 module can be easily installed and assembled on site when access is limited. Module assembly can be arranged in line, in an L shape, or back to back to accommodate any specific space conditions. Feed water, gas, water drain and flue connections can be located on either side of the enclosure.



Specifications

Output and Power Consumption

| Model | No. of Modules | Steam Capacity (kg/hr) | Input Capacity (kW) | Current at 230V (Amp) | No. of Outlets | Multi-Steam header diameter (mm) |
|----------------|----------------|------------------------|---------------------|-----------------------|----------------|----------------------------------|
| SKG4-E0501 N/P | 1 | 50 | 49 | 3.5 | 1 | 76 |
| SKG4-E0701 N/P | 1 | 70 | 63 | 3.5 | 1 | 76 |
| SKG4-E0801 N/P | 1 | 80 | 70 | 3.5 | 1 | 76 |
| SKG4-E1001 N/P | 1 | 100 | 73 | 3.5 | 1 | 76 |
| SKG4-E1202 N/P | 2 | 120 | 112 | 4.5 | 2 | 100 |
| SKG4-E1502 N/P | 2 | 150 | 126 | 4.5 | 2 | 100 |
| SKG4-E1702 N/P | 2 | 170 | 136 | 4.5 | 2 | 100 |
| SKG4-E2002 N/P | 2 | 200 | 146 | 4.5 | 2 | 100 |
| SKG4-E2503 N/P | 3 | 250 | 206 | 6.0 | 3 | 125 |
| SKG4-E2703 N/P | 3 | 270 | 209 | 6.0 | 3 | 125 |
| SKG4-E3003 N/P | 3 | 300 | 219 | 6.0 | 3 | 125 |
| SKG4-E3504 N/P | 4 | 350 | 279 | 7.5 | 4 | 2x 100 |
| SKG4-E3704 N/P | 4 | 370 | 282 | 7.5 | 4 | 2x 100 |
| SKG4-E4004 N/P | 4 | 400 | 292 | 7.5 | 4 | 2x 100 |

Integrated, Multi-Platform Controller

The SK4 Controller is configured specifically for your SKG4 Humidifier.

- User-friendly interface consisting of a menu driven 128 x 64 LCD with 8 function buttons for faster configuration and operation
- User rights management allows for menu to display only functions available to the category of user logged in
- Quick Config menu allows for faster and easier installation, by displaying only the most commonly used functions and configurations
- Independent scheduling system for unit operation and drain cycle, configurable via the menu or the BACnet communication interface
- In-field firmware upgradeable via SD card, USB or BACnet
- Simple viewing and exporting of trending log and alarm log

Optional features

- The selectable BACnet MS/TP or Modbus menus allow access to over 75 objects/registers for integration with a BMS and IoT (Internet of Things)
- Ethernet module
- BACnet IP or Modbus IP
- Web services make it possible to perform humidifier configurations, remote diagnostics and many more functions from any location



Specify your SKG4 online

Humidifier System Design and Specification Web Application

Ready to specify your Humidifier? Neptronic has developed a web application that saves you time when sizing and specifying Neptronic commercial, industrial or residential humidifiers.



Features

- Automatic humidification load calculation
- Web based
- Selection specific report generator
- Only options related to your selections appear
- Manage users, clients, job sites and humidifier specs
- History log

| Project | Humidifier | Dispersion | Options | Reports | Pricing |
|--|------------|---|--|--|---------|
| Type | | | | | |
| <input checked="" type="radio"/> Isothermal (Hot Steam) <input type="radio"/> Adiabatic (cold mist) | | | | | |
| Category | | | | | |
| <input type="radio"/> Commercial Electric SKE <input checked="" type="radio"/> Commercial Gas <input type="radio"/> Residential Electric <input type="radio"/> Commercial Electric SKE4 <input type="radio"/> Steam to Steam <input type="radio"/> Direct Steam | | | | | |
| Entering Air Conditions | | Indoor Conditions | | Distribution | |
| Temperature <input type="text" value="15.6"/> °C | | Temperature <input type="text" value="21.1"/> °C | | <input checked="" type="radio"/> In Duct | |
| Relative Humidity <input type="text" value="35"/> % | | Relative Humidity <input type="text" value="40"/> % | | <input type="radio"/> In Space | |
| Ventilation System | | | | | |
| <input type="radio"/> Natural <input checked="" type="radio"/> Mechanical <input type="radio"/> Economizer | | | | | |
| Total Air Flow <input type="text" value="5663"/> m ³ /hr | | | Outside Air <input type="text" value="100"/> % | | |
| Humidifier(s) | | | | | |
| <input checked="" type="checkbox"/> Enter Load Manually Entered Load <input type="text" value="2.04"/> kg/hr Total Capacity <input type="text" value="50.00"/> kg/hr Select Model | | | | | |

Easy to Use

Go to neptronic.com, select Humidisoft and log in. Enter design requirements and Humidisoft automatically calculates the humidification load and adjusts available options based on your selections. When done, print a complete schedule, CSI and/or submittal report at the click of a button.

| Project | Humidifier | Dispersion | Options | Reports | Pricing |
|--|------------|------------|--|---------|---------|
| Voltage | | | | | |
| <input type="text"/> <input checked="" type="checkbox"/> Show Voltages for current model only | | | | | |
| Gas Supply | | | Control | | |
| <input checked="" type="radio"/> Propane <input type="radio"/> Natural Gas | | | <input type="radio"/> On / Off <input checked="" type="radio"/> Modulating | | |
| Humidistat Type | | | | | |
| <input checked="" type="radio"/> None <input type="radio"/> Wall Humidistat HRO20 <input type="radio"/> Wall Humidity Sensor SHR10 <input type="radio"/> Duct Humidity Sensor (return duct) SHC80 <input type="radio"/> Wall Humidistat HRO20 + Wall Humidity Sensor SHR10 <input type="radio"/> Wall Humidistat HRO20 + Duct Humidity Sensor (return duct) SHC80 <input type="checkbox"/> Window Temperature Sensor SHW0-11 | | | | | |

Humidifier Product Line

SKE4 ⚡



Electric

- Capacities from 5 - 120 kg/hr
- Remove chamber easily, without tools
- Outdoor unit available

SKG4 🔥



Gas Fired

- Capacities from 50 - 400 kg/hr
- Modular design
- Outdoor unit available

SKS4 ↑↑↑



Steam to Steam

- Capacities from 8 - 570 kg/hr
- Scale management system for easy maintenance
- Insulated external panels

SKVF → → → ❄️



Evaporative Cooler

- Airflow up to 10194 m³/h
- ECM fan with variable output
- Compact, quiet and standalone

SKR ⚡



Residential

- Capacities from 3 - 5 kg/hr
- Permanent cleanable chamber
- Reliable siphon drain

SKH 🕒



High Pressure Atomizer

- Capacities up to 2100 kg/hr
- Up to 3 zones
- Installation in-duct or in-space

SKV → → →



Evaporative

- Free cooling up to 12°C
- Custom design to fit your application
- Hygienic operation with silver ion dosing system

SKD ~~~



Direct Steam

- Capacities from 2 - 750 kg/hr
- Jacketed or Multi-Steam™ SD/HD
- Unique electronic steam controller
- Optional pressurized condensate return (PCR) system

Distribution

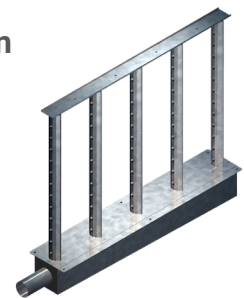

Steam Distribution

- Multi-Steam™ SD/HD distribution
- S.A.M. & S.A.M.E2 wands
- SDU (Space distribution unit)



MANUFACTURER OF

-  **HVAC CONTROLS**
-  **ELECTRIC ACTUATORS**
-  **ACTUATED VALVES**
-  **HUMIDIFIERS**
-  **ELECTRIC HEATERS**

neptronic.com