

### Models

SM000FNC: 70 in.lb. (8 Nm) without fail safe, with FT6 cable

### Features

- Brushless DC-driven motor (impedance protected)
- Contactless feedback positioner
- Mounts easily on round shafts
- Manual clutch
- Maintenance-free
- Position indicator
- Auto-stroke
- Cable
- ½" (16mm) BW BXCON-1 conduit connector (optional)
- No fail safe



SM000FNC Actuator



### Applications

- Small dampers
- Unit ventilators
- 1/4 turn valves
- VAV box control
- Fan coils

### Technical Specification

Description	SM000FNC
Torque	70 in.lb. [8 Nm] at rated voltage
Running Time (for 90° Rotation)	6 seconds torque independent
Fail Safe (Enerdrive)	No failsafe
Fail Safe Runtime (0° to 90°)	None
Capacitor Charge Time on / Power-up	None
Power Consumption	15W (during operation), 2W (at rest)
Overload Protection	Electronic throughout, 0° to 90° rotation
Power Supply	22 to 26 Vac   28 to 32 Vdc   50/60Hz
Transformer Requirements	Class 2; min. 17.5VA
Cable	5-wire FT6 plenum cable (18AWG) with strain release (NP NEP617-2)
Electrical Connection	18 AWG [0.82mm <sup>2</sup> ], 39.5" (1m) long
Impedance	100 ohms for 2-10Vdc (0.1mA)   500 ohms for 4-20mA
Control Signals	2-10Vdc (default) or 4-20mA (DIP switch selectable) / 24VAC floating
Feedback Signals	2-10Vdc (default) or 4-20mA (DIP switch selectable)
Angle of Rotation	0° to 90°, mechanically and electronically adjustable (default: 90° stroke)
Direction of Rotation	Reversible, CW: Clockwise, CCW: Counter Clockwise (default: CW)
Cycles	100,000 full cycles, 1,500,000 repositions
Noise Produced	45 dB(A)
Ingress Protection	IP54 equivalent to Nema type 3S
Operating Temperature	0°F to +122°F [-18°C to +50°C]
Storage Temperature	-22°F to +122°F [-30°C to +50°C]
Relative Humidity	5 to 95% non-condensing
Weight	2.5 lb [1.1 kg]
Purpose and Action of Control	Type 1 operating control, electric actuator
Construction of Control	Independently mounted
Pollution Degree	2
Impulse Voltage	330V
Quality Management System	ISO 9001:2015
Certification	Complies to standards: UL 60730-1 & UL 60730-2-14, CSA E60730-1 & CSA E60730-2-16
	Complies to Low Voltage Directive & Electromagnetic Compatibility Directive
	Complies to Electrical Equipment (Safety) Regulations & Electromagnetic Compatibility Regulations

**WARNING: Risk of mechanical failure. Do NOT press clutch when actuator is in operation.**

### Dimensions

- A = 1.50" (38mm)
- B = 3.64" (93mm)
- C = 6.60" (168mm)
- D = 3.02" (77mm)

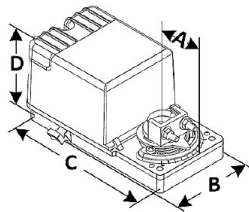

### Mechanical Installation

1. Manually close the damper blades and position the actuator to 0° or 90°.
2. Slide the actuator onto the shaft.
3. Tighten the nuts on the "U" bolt to the shaft with an 8mm wrench to a torque of 60 in.- lbs [6.7 Nm].
4. Slide the mounting bracket under the actuator. Ensure free movement of the slot at the base of the actuator. Place the bracket pin at mid distance of the slot.
5. Affix the bracket to the ductwork with #8 self-tapping screws.

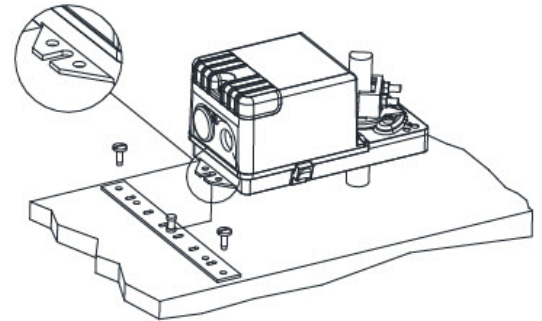

### Wiring

We strongly recommend that all products be wired to a separate grounded transformer and that transformer shall service only these products. This precaution will prevent interference with, and/or possible damage to incompatible equipment.

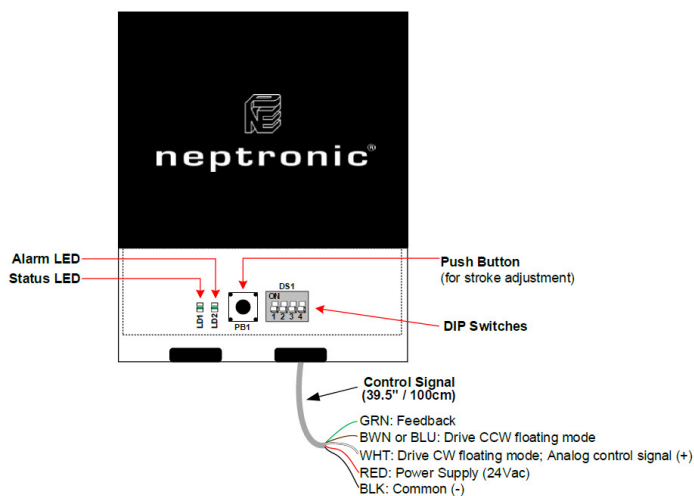
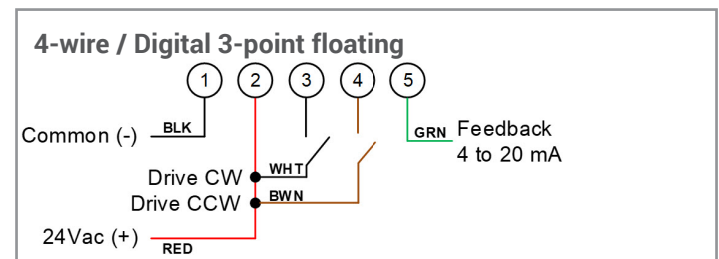
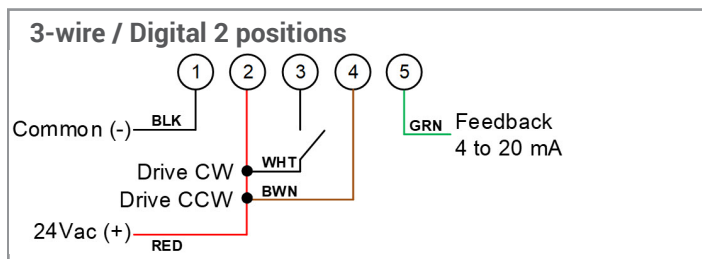
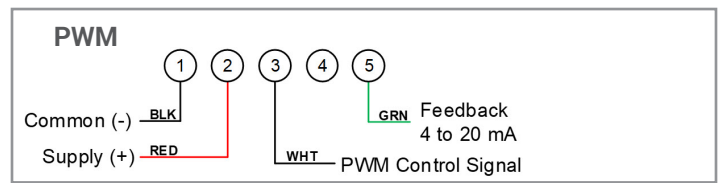
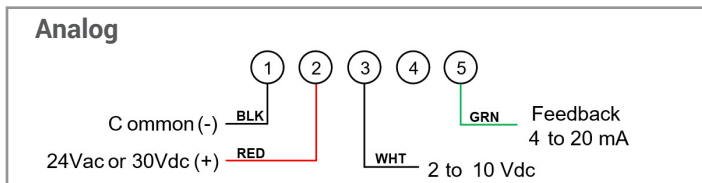

## Settings

### DIP Switches

#	Feature	OFF	ON
1	Rotation	CW *	CCW
	Fail-safe return	at 0° *	at 90°
3	Control Input signal	Vdc *	mA
4	Feedback	Vdc *	mA

\* = default

\*\* = not used

### Normal Operation

The status LED will indicate the selected control mode:

Control State	Number of Status LED Pulses
Analog	1
Digital ON/OFF or floating	2
PWM 5 seconds	3
PWM 25 seconds	4

### Status LED

State	Description
ON	Auto-stroke
Flash	Normal operation
Rapid flash	During charging of capacitors

### Alarm LED

State	Description
Flash	Error or Configuration mode

## Auto-Stroke Adjustment

**As a default, the auto-stroke feature is disabled and can only be activated manually.**

To initiate an auto-stroke process, press and release the push button while the unit is in the normal operating mode (status LED flashes slowly 1Hz). The status (green) LED will remain lit.

The actuator travels in both directions to find its limit and position itself according to the demand. The LEDs will extinguish when the process is complete. The status LED will then continue flashing slowly (1Hz).

## Configuration Instructions

- Set all the dip switches to OFF, then press and hold the push button (PB1) for 3 seconds. The red alarm LED will blink with one pulse, meaning that the first menu (Control State) is now accessible.
- Select the desired control mode by setting the associated dip switch to ON. In the absence of a selection, the control state menu shall remain unchanged.

Menu	Number of Alarm LED Pulses	Dip Switch 1	Dip Switch 2	Dip Switch 3	Dip Switch 4
Control State	1	Analog (Modulating)*	Digital (On/Off or floating)	PWM (5 sec)	PWM (25 sec)
Zero Span	2	2-10Vdc*	0-10Vdc	Minimum value	Maximum value

\* Default factory settings

- To navigate through the configuration menus, press and release the push button (PB1).
  - Press again to access the second menu (Zero Span). There will be 2 pulses on the alarm LED.
  - Press again to go back to the first menu (Control State).
- To change the span range to something other than 2-10Vdc or 0-10Vdc, access the Zero Span menu and do the following:
  - Input the desired minimum voltage to the white wire, then set dip switch 3 to ON.
  - Input the desired maximum voltage to the white wire, then set dip switch 4 to ON.
  - The maximum voltage must be at least 3V greater than the minimum voltage, and they must both lie within 0 to 10V.
- To leave the configuration menu and save any changes, press and hold the push button (PB1) for 3 seconds.
- To undo changes and reset the settings back to the factory default, press and hold the push button (PB1) for about 15 seconds.

### List of Alarms

Number of Alarm LED Pulses	Alarm	Issues	Solution
1	Power fail	The actuator is not receiving any power and is shutting off.	Ensure the actuator is properly connected the power supply source.
2	Auto-stroke	The actuator auto-stroke is not at a minimum of 30°.	Press the push button (PB1) and ensure that the span is greater than 30°.
3	Over-torque	The actuator over torque has exceeded the torque limit.	Ensure that the actuator is not trying to rotate with more than 25% of its nominal torque. Then, press the push button (PB1) to trigger an auto-stroke and clear the alarm.
4	Hardware	1. The NVM is corrupt. 2. There is no magnet installed. 3. The GMR sensor failed.	1. Visually inspect the NVM IC, remove any dust or debris from it, then perform a power cycle. 2. Ensure that the magnet is installed at a proper distance not touching the PCB or is not too far from it. It is recommended to keep it 1-2mm away. Once confirmed, perform a power cycle. 3. Visually inspect the TLI IC, remove any dust or debris from it, then perform a power cycle.

### BX Connector Attachment Installation

1. Remove the strain release NP NEP617-2 by turning it counterclockwise and slide it off the wires.
2. Insert the conduit attachment and turn it clockwise until it has been properly tightened onto the actuator attachment.



Step 1



Step 2



Recycling at end of life: please return this product to your Neptronic local distributor for recycling. If you need to find the nearest Neptronic authorized distributor, please consult [www.neptronic.com](http://www.neptronic.com).