



Models

Model	Router	Display	Communication Ports	
			BACnet Ports	Modbus Ports
CMMB-IP	-	-	1	1
CMMB-IP-L	-	Yes	1	1
CMMB-IP-R1B	Yes	-	1	-
CMMB-IP-R2B	Yes	-	2	-
CMMB-IP-RL1B	Yes	Yes	1	-
CMMB-IP-RL2B	Yes	Yes	2	-



CMMB-IP Series



CMMB-IP-L Series

Description

The CMMB-IP extends your BACnet or Modbus network when your application requires additional inputs and outputs on a physical controller. Combining the 20 inputs and outputs of the CMMB-IP with your Building Automation System provides simple expansion of a new or existing controller and reduces unnecessary costs of additional components.

Features

Power

- 24Vac or 24Vdc supply
- 22 Vdc 200 mA power output for loop powered 4-20 mA transmitters

10 Inputs

- 2 binary inputs
- 8 universal inputs

10 Outputs

- 6 binary outputs (relays)
- 4 analog outputs
- Supervised manual override of outputs via local WEB page or local dip switches

Other

- SD card slot for updates
- USB port for 5 Vdc power supply
- RJ45 Ethernet connection for IP and WEB services

Network Communication

- Up to 2 RS-485 communication ports for BACnet MS/TP or Modbus RTU
- BACnet IP, BACnet Ethernet or Modbus TCP/IP
- Set network settings via embedded WEB server
- Provision for I/O expansion modules
- Router functionality (optional)

BACnet MS/TP

- MS/TP @ 9600, 19200, 38400 or 76800 bps
- Automatic baud rate detection
- Automatic device instance configuration

BACnet IP / BACnet Ethernet

- All IP / Ethernet configuration via on board WEB page
- Display device status including each available data point. In addition to the BACnet object interface.
- Supports DHCP or fixed/static addressing

Modbus RTU

- Modbus @ 9600, 19200, 38400 or 57600 bps
- RTU Slave, 8 bits (configurable parity and stop bits)
- Connects to any Modbus master

Modbus TCP/IP

Connects to any Modbus TCP/IP master controller

Technical Specifications

Specifications	CMMB-IP Series
Input Voltage	24 Vac or 24 Vdc
Consumption	5VA (331mA @ 24 Vac)
Universal Inputs (12-bit)	8 [0-10Vdc, Thermistor, on/off (dry contact), 4-20mA] / 12-bit resolution
Binary Inputs	2 [normally open/closed or direct/reverse] / 12-bit resolution
Analog Outputs	4 [0-10Vdc] / Adjustable span 12-bit resolution
Digital Relay Binary Outputs	6 [isolated normally open/closed, independent common per relay, 5A resistive]
RS-485 Communication Connections	24 AWG twisted-shield cable (Belden 9841 or equivalent)
Electrical Connections	0.8 mm ² [18 AWG] maximum
Operational Temperature	0°C to 50°C [32°F to 122°F]
Storage Temperature	-30°C to 50°C [-22°F to 122°F]
Relative Humidity	5 a 95% non condensed
Weight	0.6 kg [1.3 lb]
Dimensions A = 9.18" / 233 mm B = 4.93" / 125 mm C = 2.27" / 58 mm	





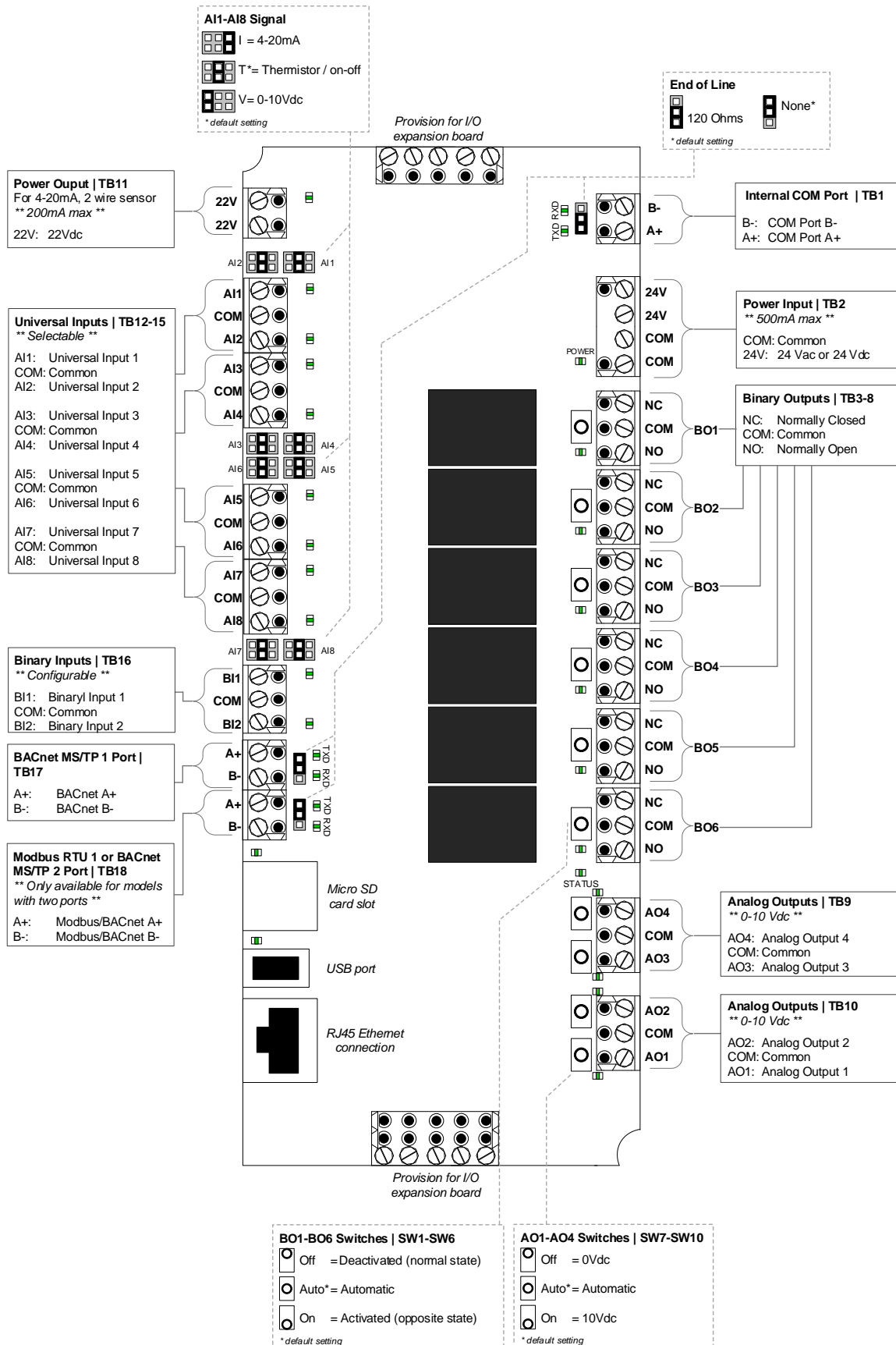

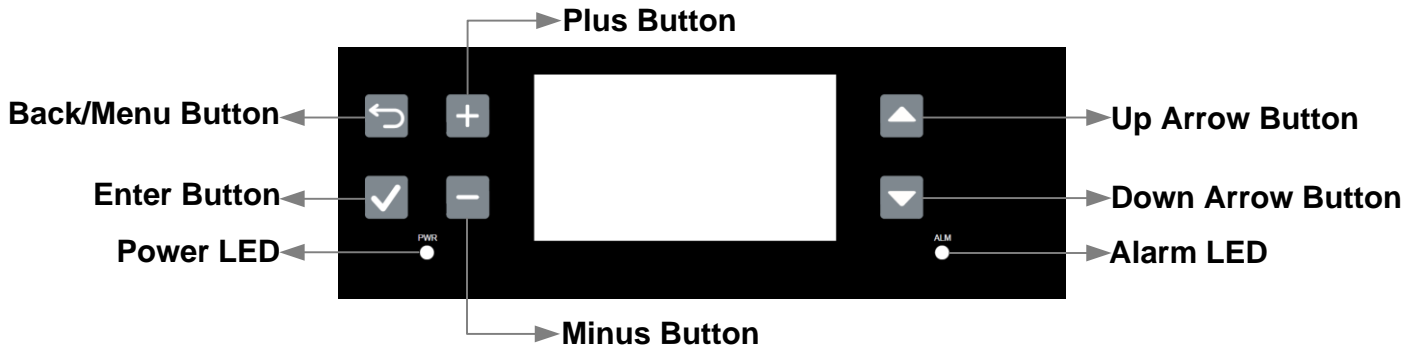



Connections and Configurations

Please note that all jumper settings must also be set to the same value through BACnet.
Some additional configurations are only available through BACnet (see Network Data and Utilization on page 8).



Controller Configuration (only for models CMMB-IP-L, CMMB-IP-RL1B and CMMB-IP-RL2B)

Control Panel Features

The following are the features of the Control Panel and their description:

Feature		Description
Power LED	 (Blue)	Indicates that the CMMB-IP is turned on.
	 (Off)	Indicates that the CMMB-IP is turned off.
Alarm LED	 (Red)	Indicates that the alarm is issuing a warning and that the system must be verified.
	 (Off)	Indicates that there is currently no alarm activated.
Up and Down Arrow Buttons		The up arrow button is used to scroll to the next menu item or parameter.
		The down arrow button is used to scroll to the previous menu item or parameter.
Plus and Minus Buttons		The plus button is used to increase the value of the displayed parameter.
		The minus button is used to decrease the value of the displayed parameter.
Back/Menu Button		The back/menu button is used to go to previous menu or to access the Main Menu page from the Idle Screen.
Enter Button		The enter button is used to advance to the next sub-menu, to access the selected option or to confirm set parameter value.

Idle Screen

When the controller is in operation, the unit displays the following information on the Idle Screen:

Setting	Default	Range <i>(* indicates no configuration; display only)</i>	Description/Notes
Status	Operational	* (Operational, Operational Read-Only, Download required, Download in progress, Non-operational, Backup in progress)	Displays the current system status.
DeviceInstance	0153001	*	Displays the device instance value.
MSTP1MAC	1	* (min: 1, max: 127)	Displays the local BACnet MS/TP network MAC address for port 1 (TB17).
MSTP2MAC	2	* (min: 1, max: 127)	Displays the local BACnet MS/TP network MAC address for port 2 (TB18). (Only appears for models CMMB-IP-RL2B.)



Menu Access

- From the Idle Screen, the Main Menu can be accessed by pressing the Back/Menu button ↵, enabling access to the General menu.
- To view other menu options and perform configurations to the system, press Enter ✓ while on the Idle Screen to advance to the Login Screen, where a valid password must be entered.
- Four different passwords can be used, each granting access to an additional menu option depending on the access level assigned to the provided password.
- If a password of higher access is provided, all menu options accessible with the use of a lower level password will also be unlocked.

Access Level	Password	Menu Unlocked	Description/Notes
1	None	General	Grants access to General menu.
2	2222	User	Grants access to General and User menus.
3	4433	Installation	Grants access to General, User and Installation menus.
4	5544	Integration	Grants access to General, User, Installation and Integration menus.



Note: To modify or retrieve lost passwords, please contact factory.

- After accessing the Login Screen, use the + or - buttons to increase or decrease the value of the number that is highlighted.
- Use the ▲, ▼ buttons to scroll to the next or previous number.
- Press Enter ✓ to confirm the password once completed. If you enter the wrong password, the controller displays a "Login Failed" message.
- The Back/Menu button ↵ may also be used to return to the Idle Screen display.

Menu Navigation

- Use the ▲, ▼ buttons to select the desired menu category and press Enter ✓ to advance to the next sub-menu.
- Use the + and - buttons to increase and decrease values. Use the ▲, ▼ buttons to scroll to the next or previous parameter. Values are saved as soon as a change is made.
- Press the Back/Menu button ↵ to go back one menu. The current menu location is displayed at the top of the screen.
- To exit completely, press the Back/Menu button ↵ until you return to the Idle Screen. After 5 minutes of inactivity, the controller will automatically return to the Idle Screen.



Network Settings



CAUTION: Connect the device to a secure network with a strong firewall protection, in order to prevent unauthorized access to the system.

All settings for network management, including BACnet and Modbus settings, can be made through the local web page of the controller.

The default IP address of the controller is **192.168.1.100**.

- If the newly set address is lost or the currently assigned IP address of the device cannot be remembered, use a fresh SD card to retrieve the address, by installing the new card and booting up the controller.
- After a minute, remove the SD card and open the log file using a text editor.
- The assigned IP settings are listed at the top of the log file.

```

Notice: RUNTIME=00001F41 CPU=99.2% HEAP free=289280 min=275928 dead=13984
Notice: Core Event:      0x04400001      4
Notice: Core Event:      0x0a00000a      0
Notice: Core Event:      0x04400002      4
Info:  Set      0x0080000A      1001  PRESENT_VALUE  992
Info:  Set      0x0080000B      1001  PRESENT_VALUE -1943
Info:  Set      0x008000E4      1001  PRESENT_VALUE   8
Info:  Set      0x0A00001F      1601  PRESENT_VALUE 192.168.0.61
Info:  Set      0x0A000021      1601  PRESENT_VALUE 192.168.0.100
Info:  Set      0x0A000020      1601  PRESENT_VALUE 255.255.255.0
Info:  Set      0x0A000022      1601  PRESENT_VALUE 192.168.10.50
Info:  Set      0x00000005      1101  PRESENT_VALUE   8
Info:  Set      0x00800029      1101  PRESENT_VALUE   8
Info:  Set      0x00000006      1101  PRESENT_VALUE   6
Info:  Set      0x00800031      1101  PRESENT_VALUE   6

```

Using the currently assigned IP address, load the local web page.

- Using the Login button, access the Login screen and enter the password **5544** to access all of the properties of the module.
- All network settings are found under the **Integration** tab.

The screenshot shows the web interface with the 'Integration' tab selected. The left sidebar contains 'General Settings', 'User Settings', 'Installation', and 'Integration'. The main content area is titled 'Integration' and contains a table of settings:

Object name	Present Value
Network	
▼ Device	
DeviceName (CSV.1)	CMMB IP
Location (CSV.6)	Default Location
Description (CSV.7)	CMMB IP
DeviceInstance (PIV.1)	153001
▼ HttpServer	
Http Server Units (MV.7)	Metric
▼ BACnetServer	
Ethernet enable (BV.26)	enable
BACnet Server List Mode (MV.9)	Integrator
BACnetServerUnits (MV.10)	Metric
BACnetServerCovMaxSubs (PIV.27)	56
▼ BACnetMSTP1	
MaxMaster (AV.24)	127
MaxInfoFrames (AV.25)	100
Network (AV.27)	1
MSTP1MAC (AV.163)	1
Auto Baud Rate (BV.6)	No
Baud Rate (MV.11)	19200
▼ BACnet IP	
Network Number (AV.30)	2
BacnetIP Port (PIV.50)	47808



Overrides

Under the **User** tab, the present values of the inputs and outputs can be visualised in real time.

User Settings	
Object name	Present Value
▼ Physical IO	
▼ AnalogInput1	
Analog Input 1 Signal (AI.1)	10.00V
AI1 Temperature (AV.43)	-40.00°F
▼ AnalogInput2	
Analog Input 2 Signal (AI.2)	10.00V
AI2 Temperature (AV.53)	-40.00°F
▼ AnalogInput3	
Analog Input 3 Signal (AI.3)	10.00V
AI3 Temperature (AV.63)	-40.00°F
▼ AnalogInput4	
Analog Input 4 Signal (AI.4)	10.00V
AI4 Temperature (AV.73)	-40.00°F
▼ AnalogInput5	
Analog Input 5 Signal (AI.5)	10.00V
AI5 Temperature (AV.83)	-40.00°F
▼ AnalogInput6	
Analog Input 6 Signal (AI.6)	10.00V
AI6 Temperature (AV.93)	-40.00°F
▼ AnalogInput7	
Analog Input 7 Signal (AI.7)	10.00V
AI7 Temperature (AV.103)	-40.00°F
▼ AnalogInput8	
Analog Input 8 Signal (AI.8)	10.00V

The analog and binary outputs can be overridden using the local dip switches, directly on the I/O module. The status of the output is shown as overridden on the web page.

▼ BinaryOutput1	
Binary Output 1 Signal (BO.1) (Overridden)	Open
Priority tab	
▼ BinaryOutput2	
Binary Output 2 Signal (BO.2) (Overridden)	Open
Priority tab	
▼ BinaryOutput3	
Binary Output 3 Signal (BO.3) (Overridden)	Open
Priority tab	
▼ BinaryOutput4	
Binary Output 4 Signal (BO.4)	Open
Priority tab	
▼ BinaryOutput5	
Binary Output 5 Signal (BO.5)	Open
Priority tab	
▼ BinaryOutput6	
Binary Output 6 Signal (BO.6)	Open
Priority tab	
▼ AnalogOutput1	
A01 Percentage (AV.127)	0.0%
Priority tab	
A01 Binary (BV.27)	Open
Priority tab	



LEDs

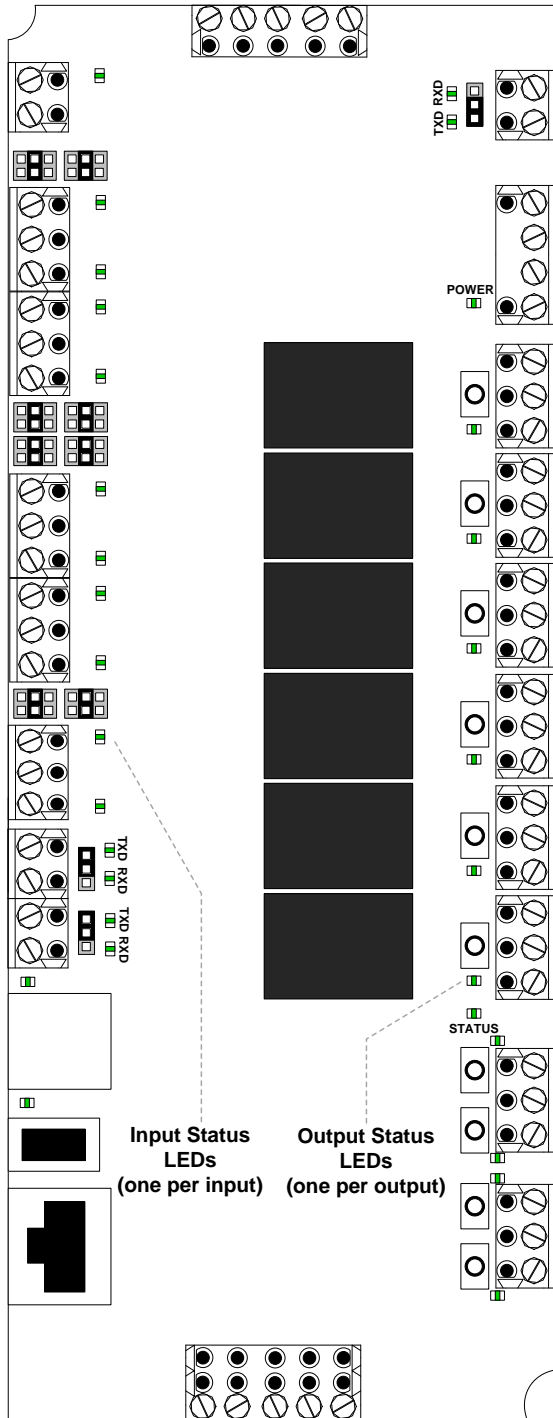

Power

- On = Input voltage normal
- Off = No power

Status

- Flashing = Normal operation (watchdog)

RX/TX

- Flashing = Receiving (RX) and/or transmitting (TX) data.

Input Status

- On = Input on
- Off = Input off
- Flashing = Input not connected (thermistor setting only)
- Analog = When Universal Inputs are set to analog values (Vdc, mA, or Thermistor); the LED intensity corresponds to the input value. For example: At 10Vdc, the LED will be fully on. At 5Vdc, the LED will be at 50% intensity. At 0 Vdc, the LED will be off.

Output Status

- On = Activated
- Off = Deactivated
- Flashing = Output pulsed
- Analog = When Universal and Analog outputs are set to analog values (Vdc); the LED intensity corresponds to the output value. For example: At 10Vdc, the LED will be fully on. At 5Vdc, the LED will be at 50% intensity. At 0 Vdc, the LED will be off.



Network Data and Utilization

Please note that all hardware jumper settings for the universal inputs need to match the software configuration of the input.

Universal Inputs (AI1-AI8)

Ex.: Using AI3

- The configuration of the universal input will automatically hide certain objects that are not useful for that specific input configuration. Refresh your BACnet browser to expose the required and used objects.

For Thermistor Temperature Reading

- With the hardware jumper set to *Thermistor*, set the AI input type to *10K_TypeG*, *10K_Type3A1*, *10K_Type4A1*, *10K_NTC*, *20K_Type6A1* or *30K_Type6A1*. It may also be set with BACnet, by using the MSV.29 object (*AI3 Signal Type*).

User Settings	Object name	Present Value
Installation Integration	Physical IO	
	▼ AnalogInput1	
	Analog Input 1 Signal (AI.1)	10.00V
	AI1 Signal Min (AV.39)	0.00V
	AI1 Signal Max (AV.40)	10.00V
	AI1 Temperature (AV.43)	-40.00°F
	AI1 Temperature Min (AV.44)	-40.00°F
	AI1 Temperature Max (AV.45)	212.00°F
	AI1 Temperature Bias (AV.46)	0.00Δ°F
	AI1 Signal Type (MV.27)	10K_TypeG
	▼ AnalogInput2	
	Analog Input 2 Signal (AI.2)	0_10V
	AI2 Signal Min (AV.49)	4_20mA
	AI2 Signal Max (AV.50)	
	AI2 Temperature (AV.53)	10K_TypeG
	AI2 Temperature Min (AV.54)	10K_Type3A1
	AI2 Temperature Max (AV.55)	10K_Type4A1
	AI2 Temperature Bias (AV.56)	
	AI2 Signal Type (MV.28)	10K_NTC
	▼ AnalogInput3	
	Analog Input 3 Signal (AI.3)	20K_Type6A1
	AI3 Signal Min (AV.59)	
	AI3 Signal Max (AV.60)	30K_Type6A1
	AI3 Temperature (AV.63)	Digital_Input
	AI3 Temperature Min (AV.64)	

- The objects used for AI3 in this configuration are:
 - AI3 Temperature (AV.63)*, when used in thermistor mode.
 - AI3 Temperature Min (AV.64)*.
 - AI3 Temperature Max (AV.65)*.
 - AI3 Temperature Bias (AV.66)*, used for calibration offset.

For On/Off Contact Input Reading

- With the hardware jumper set to *Thermistor*, set the AI input type to *Digital_Input*. It may also be set with BACnet, by using the MSV.29 object (*AI3 Signal Type*).
- The objects used for AI3 in this configuration are:
 - AI3 Binary (BV.14)*

For Analog 0-10 Vdc Input Reading

- With the hardware jumper set to *0-10 Vdc*, set the AI input type to *0_10V*. It may also be set with BACnet, by using the MSV.29 object (*AI3 Signal Type*).
- The objects used for AI3 in this configuration are:
 - AI3 Signal (AV.3)*
 - AI3 Signal Min (AV.59)*, can be used to customize the signal input voltage span.
 - AI3 Signal Max (AV.60)*, can be used to customize the signal input voltage span.
 - AI3 Temperature (AV.63)*, when used in temperature mode with a 0-10 Vdc temperature transmitter.
 - AI3 Temperature Min (AV.64)*, when used in temperature mode with a 0-10 Vdc temperature transmitter.
 - AI3 Temperature Max (AV.65)*, when used in temperature mode with a 0-10 Vdc temperature transmitter.

For Analog 4-20 mA Input Reading

- With the hardware jumper set to *4-20 mA*, set the AI input type to *4_20mA*. It may also be set with BACnet, by using the MSV.29 object (*AI3 Signal Type*).
- The objects used for AI3 in this configuration are:
 - AI3 Signal (AV.3)*. Please note that the value is still shown in Vdc after the 500Ω shunt resistor.
 - AI3 Signal Min (AV.59)*, can be used to customize the signal input voltage span.
 - AI3 Signal Max (AV.60)*, can be used to customize the signal input voltage span.
 - AI3 Temperature (AV.63)*, when used in temperature mode with a 4-20 mA temperature transmitter.
 - AI3 Temperature Min (AV.64)*, when used in temperature mode with a 4-20 mA temperature transmitter.
 - AI3 Temperature Max (AV.65)*, when used in temperature mode with a 4-20 mA temperature transmitter.



Binary Inputs (BI1-BI2)

- Both BI's can be monitored through the BI1 and BI2 objects.

Analog Outputs (AO1-AO4)

- The AO objects support priority array for writing with BACnet.
- The local switch can be overridden by the network as long as the priority level is inferior to 16 (1 to 15).
- The objects used by the AO's are:

Ex.: for AO1

Analog Output AO1 Signal (AO.1).

Minimum Voltage AO1 (AV.125), can be used to customize the signal output voltage span.

Maximum Voltage AO1 (AV.126), can be used to customize the signal output voltage span.

AO1 Percentage (AV.127).

Binary Outputs (BO1-BO6)

- The BO objects support priority array for writing with BACnet.
- The local switch can be overridden by the network as long as the priority level is inferior to 16 (1 to 15).
- The objects used by the AO's are:

Ex.: for BO1

Binary Output BO1 Signal (BO.1).

Supervised Outputs

- All outputs are fully supervised via BACnet or Modbus. This provides the actual state of the output including any manual overrides done using the on-board switches.

Web Page/Controller Menu Configuration



Note: Available settings and range selections may vary depending on product model and current configuration. The tables in the following sections display all the possible selections. The Description/Notes column indicates the conditions required for the associated setting to appear.

Menu - General [Level 1 - No password required]

Sub-Menu	Setting	Default	Range (* indicates no configuration; display only) (** configurable only with level 3 access in menu) (*** configurable only with level 4 access in menu)	Description/Notes
Network	Device (Device)			
	DeviceInstance (DeviceInstance)	0153001	**	Displays the device instance value.
Communication	DHCP Enable (DHCP)	Inactive	*** (Inactive, Active)	Displays whether Dynamic Host Configuration Protocol (DHCP) is enabled to automatically provide an IP address.
	StaticAddress (StaticAddress)	192.168.1.100	***	Displays the static IP address.
	ActualAddress (ActualAddress)	Current Value	*	Displays the actual IP address.
System	SystemStatus (Status)	Operational	* (Operational, Operational Read-Only, Download required, Download in progress, Non-operational, Backup in progress)	Displays the current system status.
	VendorName (Vendor)	Neptronic	*	Displays the name of the vendor of the product. (Always Neptronic)
	ModelName (Model)	-	*	Displays the controller model name.
	Application Version (AppVersion)	3.03.20220503	*	Displays the current application software version.
	SerialNumber (SerialNo)	-	*	Displays the serial number of the controller.
	ProfileName (Profile)	-	*	Displays a short profile for the configured device.
	MCULoad (MCULoad)	Current value	* (min: 0 %, max: 100%)	Displays the current microcontroller load.
	MemoryLoad (MemoryLoad)	Current value	* (min: 0%, max: 100%)	Displays the current memory load.
System Reset Reason (ResetReason)	None	* (None, BOR, Pin, POR, Soft, IWDG, WWDG, LPWR, Unknown)	Displays the reason for the previous system reset: None = No Reset; BOR = Brownout Reset; Pin = Pin Reset; POR = Power-on Reset; Soft = Software Reset; IWDG = Independent Watchdog; WWDG = Windowed Watchdog; LPWR = Low Power Reset; Unknown = Unknown Cause	

Menu - User [Level 2 - Requires level 2 (or higher) password in order to access]

Sub-Menu	Setting	Default	Range <i>(* indicates no configuration; display only)</i> <i>(** configurable only with level 3 access in menu)</i>	Description/Notes	
Physical IO	AnalogInput1-8 <i>(AI1 to AI8)</i>				
		Analog Input 1-8 Signal <i>(Signal)</i>	<i>Current Value</i>	* (min: 0.00V, max: 10.00V)	Displays the actual voltage on the analog input in Vdc.
		AI1-8 Temperature <i>(Temp)</i>	<i>Current Value</i>	* (min: -40.00°C, max: 100.00°C) * [min: -40.00°F, max: 212.00°F] Units: C, F	In thermistor mode, it displays the actual temperature read by the 10K thermistor. In voltage or mA mode, it displays the temperature as set per the Temperature Min and Max parameters. (Only appears if AI1-8 Signal Type is not set to Digital_Input.)
		Analog Input 1-8 Pulse Count <i>(PulseCnt)</i>	0	* (min: 0, max: 999999999)	Displays the number of pulses for the analog input. (Only appears if AI1-8 Signal Type is set to Digital_Input.)
		AI1-8 Binary <i>(BV)</i>	<i>Current Value</i>	* (Open, Close)	Displays the status of the analog input in Digital Input mode. (Only appears if AI1-8 Signal Type is set to Digital_Input.)
		Analog Input 1-8 Pulse Count Reset <i>(PulseCntRst)</i>	No	No, Yes	Select whether to reset the value of the analog input pulse counter. (Only appears if AI1-8 Signal Type is set to Digital_Input.)
		BinaryInput1-2 <i>(BI1 to BI2)</i>			
		Binary Input 1-2 Pulse Count <i>(PulseCnt)</i>	0	* (min: 0, max: 999999999)	Displays the number of pulses for the binary input.
		Binary Input 1-2 Signal <i>(Signal)</i>	<i>Current Value</i>	* (Open, Close)	Displays the status of the binary input.
		Binary Input 1-2 Pulse Count Reset <i>(PulseCntRst)</i>	No	No, Yes	Select whether to reset the value of binary input pulse counter.
		BinaryOutput1-6 <i>(BO1 to BO6)</i>			
		Binary Output 1-6 Signal <i>(Signal)</i>	<i>Current Value</i>	** (Open, Close)	Displays the status of the binary output.
		AnalogOutput1-4 <i>(AO1 to AO4)</i>			
		AO1-4 Percentage <i>(Percent)</i>	<i>Current Value</i>	** (min: 0.0%, max: 100.0%)	Displays the analog output value in percentage.
	AO1-4 Binary <i>(BinaryValue)</i>	<i>Current Value</i>	** (Open, Close)	Displays the status of the analog output. (Only appears if AO1-4 Mode is set to Digital.)	
System	UTCOffset <i>(UTCOffset)</i>	-300min	min: -720min, max: 720min	Select the value of the UTC offset.	
	DaylightSavingsStatus <i>(DaylightSavings)</i>	No	No, Yes	Select whether to enable daylight savings mode or not.	
	LocalDateTime <i>(LocalDateTime)</i>	YYYY-MM-DD 00:00:00		Configure the current date and time.	
User Interface	Local Display Backlight Level <i>(BacklightLvl)</i>	25%	min: 0%, max: 100%	Select the backlight level of the LCD screen.	
	Local Display Contrast Level <i>(Contrast)</i>	10%	min: 0%, max: 30%	Select the contrast level of the LCD screen.	

Sub-Menu	Setting	Default	Range <i>(* indicates no configuration; display only)</i> <i>(** configurable only with level 3 access in menu)</i>	Description/Notes
User Interface	Local Display Units (Units)	Metric	Metric, Imperial	Select whether to use a metric or imperial system of units for the local device.

[Menu - Installation](#) [Level 3 - Requires level 3 (or higher) password in order to access]

Sub-Menu	Setting	Default	Range <i>(* indicates no configuration; display only)</i> <i>(** configurable only with level 4 access in menu)</i>	Description/Notes
Import User Config				Import all the controller configuration values onto the SD card or USB device. A SD card or USB device must be inserted in order to import the values. (Only appears on the device menu).
Export User Config				Export all the controller configuration values onto the SD card or USB device. A SD card or USB device must be inserted in order to export the values. (Only appears on the device menu).
Physical IO	AnalogInput1-8 <i>(A11 to A18)</i>			
	Analog Input 1-8 Signal <i>(Signal)</i>	Current Value	* (min: 0.00V, max: 10.00V)	Displays the actual voltage on the analog input in Vdc.
	A11-8 Signal Min <i>(SignalMin)</i>	0.0V	min: 0.0V, max: 10.0V	Select the minimum Vdc voltage of the input for the 0-10 Vdc input mode.
	A11-8 Signal Max <i>(SignalMax)</i>	10.0V	min: 0.0V, max: 10.0V	Select the maximum Vdc voltage of the input for the 0-10 Vdc input mode.
	A11-8 Temperature <i>(Temp)</i>	Current Value	* (min: -40.00°C, max: 100.00°C) * [min: -40.00°F, max: 212.00°F] Units: C, F	In thermistor mode, it displays the actual temperature read by the 10K thermistor. In voltage or mA mode, it displays the temperature as set per the Temperature Min and Max parameters. (Only appears if A11-8 Signal Type is not set to Digital_Input.)
	A11-8 Temperature Min <i>(TempMin)</i>	-40.0°C [-40.0°F]	min: -50.0°C, max: 10.0°C (min: -58.0°F, max: 50.0°F) Units: C, F	In voltage or mA mode, it sets the minimum temperature range of the selected transmitter. (Only appears if A11-8 Signal Type is not set to Digital_Input.)
	A11-8 Temperature Max <i>(TempMax)</i>	100.0°C [212.0°F]	min: 40.0°C, max: 125.0°C (min: 104.0°F, max: 257.0°F) Units: C, F	In voltage or mA mode, it sets the maximum temperature range of the selected transmitter. (Only appears if A11-8 Signal Type is not set to Digital_Input.)
	A11-8 Temperature Bias <i>(TempBias)</i>	0.00°C [0.00°F]	min: -10.00°C, max: 10.00°C (min: -18.00 °F, max: 18.00°F) Units: C, F	In thermistor mode, it allows for a calibration offset of the input. (Only appears if A11-8 Signal Type is not set to Digital_Input.)
	A11-8 Binary <i>(BV)</i>	Current Value	* (Open, Close)	Displays the status of the analog input in Digital Input mode. (Only appears if A11-8 Signal Type is set to Digital_Input.)
	A11-8 Polarity <i>(Polarity)</i>	Direct	Direct, Reverse	Select the polarity of the analog input in the Digital Input mode. (Only appears if A11-8 Signal Type is set to Digital_Input.)
	A11-8 Signal Type <i>(SignalType)</i>	10K_TypeG	0_10V, 4_20mA, 10K_TypeG, 10K_Type3A1, 10K_Type4A1, 10K_NTC, 20K_Type6A1, 30K_Type6A1, Digital_Input	Select the input mode type operation. This setting should be the same as the jumper hardware configuration on the PCB.
	BinaryInput1-2 <i>(B11 to B12)</i>			
	B11-2 Polarity <i>(Polarity)</i>	Direct	Direct, Reverse	Select the polarity of binary input.
	BinaryOutput1-6 <i>(BO1 to BO6)</i>			
	Binary Output 1-6 Signal <i>(Signal)</i>	Open	Open, Close	Select the status of the binary output.
Binary Output 1-6 Fail Safe State <i>(FailSafeState)</i>	LastState	LastState, Open, Close	Select the fail-safe state for the binary output.	

Sub-Menu	Setting	Default	Range <i>(* indicates no configuration; display only)</i> <i>(** configurable only with level 4 access in menu)</i>	Description/Notes
Physical IO	AnalogOutput1-4 <i>(AO1 to AO4)</i>			
	Analog Output 1-4 Signal <i>(Signal)</i>	<i>Current Value</i>	** (min: 0.000V, max: 10.000V)	Displays the actual voltage on the analog output in Vdc.
	Minimum Voltage AO1-4 <i>(SignalMin)</i>	0.00V	min: 0.00V, max: 10.00V	Select the minimum Vdc voltage of the output for the 0-10 Vdc output.
	Maximum Voltage AO1-4 <i>(SignalMax)</i>	10.00V	min: 0.00V, max: 10.00V	Select the maximum Vdc voltage of the output for the 0-10 Vdc output.
	AO1-4 Percentage <i>(Percent)</i>	0.0%	** (min: 0.0%, max: 100.0%)	Displays the analog output value in percentage.
	AO1-4 Binary <i>(BinaryValue)</i>	Open	Open, Close	Select the status of the analog output. (Only appears if AO1-4 Mode is set to Digital.)
	AO1-4 Polarity <i>(Polarity)</i>	Direct	Direct, Reverse	Select the polarity of analog output.
	AO1-4 Mode <i>(Mode)</i>	Analog	Analog, Pulsed, Digital	Select the mode for the analog output.
	Analog Output 1-4 Fail Safe State <i>(FailSafeState)</i>	LastState	LastState, Preset	Select the fail-safe state for the analog output.
	Analog Output 1-4 Fail Safe Preset <i>(FailSafePreset)</i>	0.0%	min: 0.0%, max: 100.0%	Set the value of fail-safe preset for the analog output.
System	Reset Factory <i>(ResetFactory)</i>	No	No, Yes	Select Yes in order to reset the controller back to its original factory configuration settings. <u>WARNING:</u> There is no way to recover previous configurations once the device has been reset.

Menu - Integration [Level 4 - Requires level 4 password in order to access]

Sub-Menu	Setting	Default	Range <i>(*indicates no configuration; display only)</i>	Description/Notes
Network	Device <i>(Device)</i>			
	DeviceName <i>(DeviceName)</i>	-		Define the BACnet device name property.
	Location <i>(Location)</i>	-		Define the BACnet device location property.
	Description <i>(Description)</i>	-		Define the BACnet device description property.
	DeviceInstance <i>(DeviceInstance)</i>	0153001		Define the BACnet device instance property.
	Network Timeout Delay <i>(NtwkTimeout)</i>	60 sec	min: 30 sec, max: 600 sec	Set the network timeout delay.
	HttpServer <i>(HttpServer)</i>			
	Http Server Units <i>(HttpServerUnits)</i>	Metric	Metric, Imperial	Select whether to use a metric or imperial system of units for the web server.
	BACnetServer <i>(BACnetServer)</i>			
	Ethernet enable <i>(Eth enable)</i>	Disable	Disable, Enable	Select whether to enable or disable the Ethernet option.
	BACnet Server List Mode <i>(ListMode)</i>	Integrator	Integrator, Advanced, Factory	Select the category of BACnet objects to display.
	BACnetServerUnits <i>(Units)</i>	Metric	Metric, Imperial	Select whether to use a metric or imperial system of units for the BACnet server.
	BACnetServerCovMaxSubs <i>(CovMaxSubs)</i>	15	min: 0, max: 255	Select the maximum number of BACnet COV subscriptions allowed.
	Network Timeout Failsafe <i>(TimeoutState)</i>	Ok	* (Ok, Timeout)	Displays the network timeout fail-safe state.
	BACnetMSTP1 <i>(BACnetMSTP1)</i>			
	MaxMaster <i>(MaxMaster)</i>	127	min: 1, max: 127	Configure the MaxMaster BACnet MS/TP value to limit the PFM range of the local device.
	MaxInfoFrames <i>(MaxInfoFrames)</i>	1	min: 1, max: 100	Configure the maximum number of information messages the device may transmit, before it must pass the token to the next device. More MS/TP messages can be routed when the device has the token. This property allows the device to also act as a local router.
	Network <i>(Network)</i>	1	min: 1, max: 65534	Set the local BACnet MS/TP network number.
	Auto Baud Rate <i>(AutoBaud)</i>	No	No, Yes	Select whether the BACnet MS/TP network will automatically detect the baud rate or if it will use the fixed value set in the <i>Baud Rate</i> parameter.
	Baud Rate <i>(BaudRate)</i>	19200	9600, 19200, 38400, 76800	Set the BACnet MS/TP baud rate when <i>Auto Baud Rate</i> is set to <i>No</i> .
MSTP1MAC <i>(MSTP1MAC)</i>	1	min: 1, max: 127	Set the local BACnet MS/TP network MAC address.	

Sub-Menu	Setting	Default	Range <i>(*indicates no configuration; display only)</i>	Description/Notes	
Network	BACnet IP <i>(BACnet IP)</i>				
		Network Number <i>(NtwkNumber)</i>	2	min: 1, max: 65534	Set the local BACnet IP network number.
		BacnetIP Port <i>(BaCnetIPPort)</i>	47808	min: 0, max: 65535	Set the BACnet IP port used by the device.
	BACnet Ethernet <i>(BACnetETH)</i>				Only appears if Ethernet enable is set to enable.
		Network Number <i>(NtwkNumber)</i>	3	min: 0, max: 65534	Set the local BACnet Ethernet network number.
	ModbusServer <i>(ModbusServer)</i>				
		Modbus Server Units <i>(Units)</i>	Metric	Metric, Imperial	Select whether to use a metric or imperial system of units for the Modbus server.
	ModbusRTU1In <i>(ModbusRTU1In)</i>				Only appears for models CMMB-IP and CMMB-IP-L.
		Modbus RTU MAC <i>(MAC)</i>	1	min: 1, max: 247	Set the local Modbus RTU MAC address.
		Modbus RTU Autobaud <i>(AutoBaud)</i>	No	No, Yes	Select whether the Modbus RTU network will automatically detect the baud rate or if it will use the fixed value set in the <i>Modbus RTU1 Baud Rate</i> parameter.
		Modbus RTU Com Port Config <i>(PortConfig)</i>	No Parity 2 Stop Bits	No Parity 2 Stop Bits, Even Parity 1 Stop bit, Odd Parity 1 Stop bit	Set the Parity and Stop Bits used for the Modbus RTU RS485 port.
		Modbus RTU Baud Rate <i>(Baudrate)</i>	38400	9600, 14400, 19200, 38400, 57600	Set the Modbus RTU baud rate when <i>Modbus RTU Autobaud</i> is set to <i>No</i> .
	ModbusTCPIP0In <i>(ModbusTCPIP0In)</i>				
		Modbus TCP IP Keep Alive Time Out <i>(KeepAliveTimeOut)</i>	5min	min: 1min, max: 1440min	Set the amount of time the Modbus communication stays open before connection is cut out, when no signal is received from the device.
		Modbus TCP IP Listening Port <i>(Listening Port)</i>	502	min: 0, max: 65535	Set the communication port number. Modbus TCP port number is set by default.
	BACnetMSTP2 <i>(BACnetMSTP2)</i>				Only appears for models CMMB-IP-R2B and CMMB-IP-RL2B.
		MaxMaster <i>(MaxMaster)</i>	127	min: 1, max: 127	Configure the MaxMaster BACnet MS/TP value to limit the PFM range of the local device.
		MaxInfoFrames <i>(MaxInfoFrames)</i>	1	min: 1, max: 100	Configure the maximum number of information messages the device may transmit, before it must pass the token to the next device. More MS/TP messages can be routed when the device has the token. This property allows the device to also act as a local router.
		Network <i>(Network)</i>	4	min: 1, max: 65534	Set the local BACnet MS/TP network number.
		Auto Baud Rate <i>(AutoBaud)</i>	No	No, Yes	Select whether the BACnet MS/TP network will automatically detect the baud rate or if it will use the fixed value set in the <i>Baud Rate</i> parameter.
	Baud Rate <i>(BaudRate)</i>	19200	9600, 19200, 38400, 76800	Set the BACnet MS/TP baud rate when <i>Auto Baud Rate</i> is set to <i>No</i> .	
	MSTP2MAC <i>(MSTP2MAC)</i>	2	min: 1, max: 127	Set the local BACnet MS/TP network MAC address.	

Sub-Menu	Setting	Default	Range <i>(*indicates no configuration; display only)</i>	Description/Notes	
Network	SMTP <i>(SMTP)</i>				
		SMTP SSL <i>(SSL)</i>	Off	Off, On	Select whether to use a secure socket layer encrypt the communication between the device and the email server or to use the default socket. If turned to <i>On</i> , SMTP Port value must be set to <i>587</i> and <i>SMTP Username</i> and <i>SMTP Password</i> settings must be filled out. If turned to <i>Off</i> , use SMTP Port <i>25</i> to use server without login account or SMTP Port <i>587</i> if login details for email account have been entered.
		SMTP Port <i>(Port)</i>	25	25, 587	Select the port number to be used for email transfer. If set to <i>25</i> , server to server email transfer is enabled (can only be used if SMTP SSL is set to <i>Off</i>). If set to <i>587</i> , client to server email transfer is enabled.
		SMTP Server IP Address <i>(ServerAddr)</i>	192.168.100.100		Configure the server IP address for the email account.
		SMTP Mail From <i>(From)</i>	-		Set the email address that will be sending the notification messages.
		SMTP Mail To <i>(To)</i>	-		Set the email address that will be receiving the notification messages.
		SMTP Username <i>(Username)</i>	-		Set the login username for the email account.
		SMTP Password <i>(Password)</i>	-		Set the login password for the email account.
		Notify <i>(Notify)</i>			
		Notify Alarm <i>(Alarm)</i>	Off	Off, On	Select whether to get notified of all alarm messages by email.
	Notify Warning <i>(Warning)</i>	Off	Off, On	Select whether to get notified of all warning messages by email.	
	Notify App Msg <i>(AppMsg)</i>	Off	Off, On	Select whether to get notified of all event messages by email.	
Communication	IP Settings <i>(IPSettings)</i>				
		DHCP Enable <i>(DHCP)</i>	Inactive	Inactive, Active	Select whether to enable Dynamic Host Configuration Protocol (DHCP) to automatically provide an IP address to the device.
		Reset IP Settings <i>(RstIPSetting)</i>	No	No, Yes	Select whether to restart the IP module, in order to allow recent parameter modifications to be effective. This setting will automatically revert to <i>No</i> once the new settings are effective.
		StaticAddress <i>(StaticAddress)</i>	192.168.1.100		Set the local IP static address.
		StaticSubnetMask <i>(StaticSubnet)</i>	255.255.255.0		Set the local IP static subnet mask.
		StaticDefaultGateway <i>(StaticGateway)</i>	192.168.0.100		Set the local IP static default gateway.
		StaticDnsServer <i>(StaticDns)</i>	192.168.10.50		Set the local IP static DNS server (if used).
		ActualAddress <i>(ActualAddress)</i>	<i>Current Value</i>	*	Displays the actual local IP static address.
	ActualSubnetMask <i>(ActualSubnet)</i>	<i>Current Value</i>	*	Displays the actual local IP static subnet mask.	

Sub-Menu	Setting	Default	Range <i>(*indicates no configuration; display only)</i>	Description/Notes
Communication	ActualDefaultGateway <i>(ActualGateway)</i>	<i>Current Value</i>	*	Displays the actual local IP static default gateway.
	ActualDnsServer <i>(ActualDns)</i>	<i>Current Value</i>	*	Displays the actual local IP static DNS server (if used).
	Ethernet Settings <i>(ETHSettings)</i>			
	EthernetMacAdd <i>(EthernetMacAdd)</i>	<i>Current Value</i>	*	Displays the local Ethernet adapter MAC address.
Network Diagnostic	BACnetMSTP1 <i>(BACnetMSTP1)</i>			
	MSTP1RxValid <i>(RxValid)</i>	0	*	Displays information on the received communication frames for troubleshooting purposes.
	MSTP1RxInvalid <i>(RxInvalid)</i>	0	*	
	MSTP1RxLost <i>(RxLost)</i>	0	*	
	MSTP1Tx <i>(Tx)</i>	0	*	Displays information on the transmitted communication frames for troubleshooting purposes.
	MSTP1TxLost <i>(TxLost)</i>	0	*	
	BACnet IP <i>(BACnetIP)</i>			
	IP0RxValid <i>(RxValid)</i>	0	*	Displays information on the received communication frames for troubleshooting purposes.
	IP0RxInvalid <i>(RxInvalid)</i>	0	*	
	IP0RxLost <i>(RxLost)</i>	0	*	
	IP0Tx <i>(Tx)</i>	0	*	Displays information on the transmitted communication frames for troubleshooting purposes.
	IP0TxLost <i>(TxLost)</i>	0	*	
	BACnet Ethernet <i>(BACnetETH)</i>			
	Only appears if <i>Ethernet enable</i> is set to <i>enable</i>.			
	ETH0RxValid <i>(RxValid)</i>	0	*	Displays information on the received communication frames for troubleshooting purposes.
	ETH0RxInvalid <i>(RxInvalid)</i>	0	*	
	ETH0RxLost <i>(RxLost)</i>	0	*	
	ETH0Tx <i>(Tx)</i>	0	*	Displays information on the transmitted communication frames for troubleshooting purposes.
	ETH0TxLost <i>(TxLost)</i>	0	*	
	BACnetMSTP2 <i>(BACnetMSTP2)</i>			
Only appears for models CMMB-IP-R2B and CMMB-IP-RL2B.				
MSTP2RxValid <i>(RxValid)</i>	0	*	Displays information on the received communication frames for troubleshooting purposes.	

Sub-Menu	Setting	Default	Range <i>(*indicates no configuration; display only)</i>	Description/Notes
Network Diagnostic	MSTP2RxInvalid <i>(RxInvalid)</i>	0	*	
	MSTP2RxLost <i>(RxLost)</i>	0	*	Displays information on the received communication frames for troubleshooting purposes.
	MSTP2Tx <i>(Tx)</i>	0	*	Displays information on the transmitted communication frames for troubleshooting purposes.
	MSTP2TxLost <i>(TxLost)</i>	0	*	



BACnet Objects Table

ID ¹	Name	Description	Writable?	Range
AI.1	Analog Input 1 Signal	Displays the actual voltage on the analog input in Vdc.	Out of service	0 to 10Volt or -40 to 100°C or -40 to 212°F or 4 to 20mA or 0 to 1 Resolution: 0.01Volt or 0.01°C/0.02°F or 0.01mA or 1
AI.2	Analog Input 2 Signal	Displays the actual voltage on the analog input in Vdc.	Out of service	0 to 10Volt or -40 to 100°C or -40 to 212°F or 4 to 20mA or 0 to 1 Resolution: 0.01Volt or 0.01°C/0.02°F or 0.01mA or 1
AI.3	Analog Input 3 Signal	Displays the actual voltage on the analog input in Vdc.	Out of service	0 to 10Volt or -40 to 100°C or -40 to 212°F or 4 to 20mA or 0 to 1 Resolution: 0.01Volt or 0.01°C/0.02°F or 0.01mA or 1
AI.4	Analog Input 4 Signal	Displays the actual voltage on the analog input in Vdc.	Out of service	0 to 10Volt or -40 to 100°C or -40 to 212°F or 4 to 20mA or 0 to 1 Resolution: 0.01Volt or 0.01°C/0.02°F or 0.01mA or 1
AI.5	Analog Input 5 Signal	Displays the actual voltage on the analog input in Vdc.	Out of service	0 to 10Volt or -40 to 100°C or -40 to 212°F or 4 to 20mA or 0 to 1 Resolution: 0.01Volt or 0.01°C/0.02°F or 0.01mA or 1
AI.6	Analog Input 6 Signal	Displays the actual voltage on the analog input in Vdc.	Out of service	0 to 10Volt or -40 to 100°C or -40 to 212°F or 4 to 20mA or 0 to 1 Resolution: 0.01Volt or 0.01°C/0.02°F or 0.01mA or 1
AI.7	Analog Input 7 Signal	Displays the actual voltage on the analog input in Vdc.	Out of service	0 to 10Volt or -40 to 100°C or -40 to 212°F or 4 to 20mA or 0 to 1 Resolution: 0.01Volt or 0.01°C/0.02°F or 0.01mA or 1
AI.8	Analog Input 8 Signal	Displays the actual voltage on the analog input in Vdc.	Out of service	0 to 10Volt or -40 to 100°C or -40 to 212°F or 4 to 20mA or 0 to 1 Resolution: 0.01Volt or 0.01°C/0.02°F or 0.01mA or 1
AO.1	Analog Output 1 Signal	Commands the voltage on the analog output in Vdc.	Out of service Present Value	0 to 10V, Resolution: 0.001V
AO.2	Analog Output 2 Signal	Commands the voltage on the analog output in Vdc.	Out of service Present Value	0 to 10V, Resolution: 0.001V
AO.3	Analog Output 3 Signal	Commands the voltage on the analog output in Vdc.	Out of service Present Value	0 to 10V, Resolution: 0.001V
AO.4	Analog Output 4 Signal	Commands the voltage on the analog output in Vdc.	Out of service Present Value	0 to 10V, Resolution: 0.001V
AV.10	MCU Load	Displays the MCU usage load.	Out of service	0 to 100%, Resolution: 1%
AV.11	Memory Load	Displays the memory usage load.	Out of service	0 to 100%, Resolution: 1%
AV.39	AI1 Signal Min	Select the minimum Vdc voltage of the input for the 0-10 Vdc input mode.	Out of service Present Value	0 to 10V, Resolution: 0.5V
AV.40	AI1 Signal Max	Select the maximum Vdc voltage of the input for the 0-10 Vdc input mode.	Out of service Present Value	0 to 10V, Resolution: 0.5V
AV.43	AI1Temperature	In thermistor mode, it displays the actual temperature read by the 10K thermistor. In voltage or mA mode, it displays the temperature as set per the Temperature Min and Max parameters.	Out of service	-40 to 100°C or -40 to 212°F, Resolution: 0.01°C or 0.018°F
AV.44	AI1 Temperature Min	In voltage or mA mode, it sets the minimum temperature range of the selected transmitter.	Out of service Present Value	-50 to 10°C or -58 to 50°F, Resolution: 0.5°C or 0.9°F
AV.45	AI1 Temperature Max	In voltage or mA mode, it sets the maximum temperature range of the selected transmitter	Out of service Present Value	40 to 125°C or 104 to 257°F, Resolution: 0.5°C or 0.9°F
AV.46	AI1 Temperature Bias	In thermistor mode, it allows for a calibration offset of the input.	Out of service Present Value	-10 to 10°C or -18 to 18°F, Resolution: 0.01°C or 0.018°F

¹ ID is equal to ObjectType.Instance



ID ¹	Name	Description	Writable?	Range
AV.49	AI2 Signal Min	Select the minimum Vdc voltage of the input for the 0-10 Vdc input mode.	Out of service Present Value	0 to 10V, Resolution: 0.5V
AV.50	AI2 Signal Max	Select the maximum Vdc voltage of the input for the 0-10 Vdc input mode.	Out of service Present Value	0 to 10V, Resolution: 0.5V
AV.53	AI2 Temperature	In thermistor mode, it displays the actual temperature read by the 10K thermistor. In voltage or mA mode, it displays the temperature as set per the Temperature Min and Max parameters.	Out of service	-40 to 100°C or -40 to 212°F, Resolution: 0.01°C or 0.018°F
AV.54	AI2 Temperature Min	In voltage or mA mode, it sets the minimum temperature range of the selected transmitter.	Out of service Present Value	-50 to 10°C or -58 to 50°F, Resolution: 0.5°C or 0.9°F
AV.55	AI2 Temperature Max	In voltage or mA mode, it sets the maximum temperature range of the selected transmitter.	Out of service Present Value	40 to 125°C or 104 to 257°F, Resolution: 0.5°C or 0.9°F
AV.56	AI2 Temperature Bias	In thermistor mode, it allows for a calibration offset of the input.	Out of service Present Value	-10 to 10°C or -18 to 18°F, Resolution: 0.01°C or 0.018°F
AV.59	AI3 Signal Min	Selects the minimum Vdc voltage of the input for the 0-10 Vdc input mode.	Out of service Present Value	0 to 10V, Resolution: 0.5V
AV.60	AI3 Signal Max	Select the maximum Vdc voltage of the input for the 0-10 Vdc input mode.	Out of service Present Value	0 to 10V, Resolution: 0.5V
AV.63	AI3 Temperature	In thermistor mode, it displays the actual temperature read by the 10K thermistor. In voltage or mA mode, it displays the temperature as set per the Temperature Min and Max parameters.	Out of Service	-40 to 100°C or -40 to 212°F, Resolution: 0.01°C or 0.018°F
AV.64	AI3 Temperature Min	In voltage or mA mode, it sets the minimum temperature range of the selected transmitter.	Out of service Present Value	-50 to 10°C or -58 to 50°F, Resolution: 0.5°C or 0.9°F
AV.65	AI3 Temperature Max	In voltage or mA mode, it sets the maximum temperature range of the selected transmitter.	Out of service Present Value	40 to 125°C or 104 to 257°F, Resolution: 0.5°C or 0.9°F
AV.66	AI3 Temperature Bias	In thermistor mode, it allows for a calibration offset of the input.	Out of service Present Value	-10 to 10°C or -18 to 18°F, Resolution: 0.01°C or 0.018°F
AV.69	AI4 Signal Min	Select the minimum Vdc voltage of the input for the 0-10 Vdc input mode.	Out of service Present Value	0 to 10V, Resolution: 0.5V
AV.70	AI4 Signal Max	Select the maximum Vdc voltage of the input for the 0-10 Vdc input mode.	Out of service Present Value	0 to 10V, Resolution: 0.5V
AV.73	AI4 Temperature	In thermistor mode, it displays the actual temperature read by the 10K thermistor. In voltage or mA mode, it displays the temperature as set per the Temperature Min and Max parameters.	Out of service	-40 to 100°C or -40 to 212°F, Resolution: 0.01°C or 0.018°F
AV.74	AI4 Temperature Min	In voltage or mA mode, it sets the minimum temperature range of the selected transmitter.	Out of service Present Value	-50 to 10°C or -58 to 50°F, Resolution: 0.5°C or 0.9°F
AV.75	AI4 Temperature Max	In voltage or mA mode, it sets the maximum temperature range of the selected transmitter.	Out of service Present Value	40 to 125°C or 104 to 257°F, Resolution: 0.5°C or 0.9°F
AV.76	AI4 Temperature Bias	In thermistor mode, it allows for a calibration offset of the input.	Out of service Present Value	-10 to 10°C or -18 to 18°F, Resolution: 0.01°C or 0.018°F
AV.79	AI5 Signal Min	Select the minimum Vdc voltage of the input for the 0-10 Vdc input mode.	Out of service Present Value	0 to 10V, Resolution: 0.5V
AV.80	AI5 Signal Max	Select the maximum Vdc voltage of the input for the 0-10 Vdc input mode.	Out of service Present Value	0 to 10V, Resolution: 0.5V



ID ¹	Name	Description	Writable?	Range
AV.83	A15 Temperature	In thermistor mode, it displays the actual temperature read by the 10K thermistor. In voltage or mA mode, it displays the temperature as set per the Temperature Min and Max parameters.	Out of service	-40 to 100°C or -40 to 212°F, Resolution: 0.01°C or 0.018°F
AV.84	A15 Temperature Min	In voltage or mA mode, it sets the minimum temperature range of the selected transmitter.	Out of service Present Value	-50 to 10°C or -58 to 50°F, Resolution: 0.5°C or 0.9°F
AV.85	A15 Temperature Max	In voltage or mA mode, it sets the maximum temperature range of the selected transmitter.	Out of service Present Value	40 to 125°C or 104 to 257°F, Resolution: 0.5°C or 0.9°F
AV.86	A15 Temperature Bias	In thermistor mode, it allows for a calibration offset of the input.	Out of service Present Value	-10 to 10°C or -18 to 18°F, Resolution: 0.01°C or 0.018°F
AV.89	A16 Signal Min	Select the minimum Vdc voltage of the input for the 0-10 Vdc input mode.	Out of service Present Value	0 to 10V, Resolution: 0.5V
AV.90	A16 Signal Max	Select the maximum Vdc voltage of the input for the 0-10 Vdc input mode.	Out of service Present Value	0 to 10V, Resolution: 0.5V
AV.93	A16 Temperature	In thermistor mode, it displays the actual temperature read by the 10K thermistor. In voltage or mA mode, it displays the temperature as set per the Temperature Min and Max parameters.	Out of service	-40 to 100°C or -40 to 212°F, Resolution: 0.01°C or 0.018°F
AV.94	A16 Temperature Min	In voltage or mA mode, it sets the minimum temperature range of the selected transmitter.	Out of service Present Value	-50 to 10°C or -58 to 50°F, Resolution: 0.5°C or 0.9°F
AV.95	A16 Temperature Max	In voltage or mA mode, it sets the maximum temperature range of the selected transmitter.	Out of service Present Value	40 to 125°C or 104 to 257°F, Resolution: 0.5°C or 0.9°F
AV.96	A16 Temperature Bias	In thermistor mode, it allows for a calibration offset of the input.	Out of service Present Value	-10 to 10°C or -18 to 18°F, Resolution: 0.01°C or 0.018°F
AV.99	A17 Signal Min	Select the minimum Vdc voltage of the input for the 0-10 Vdc input mode.	Out of service Present Value	0 to 10V, Resolution: 0.5V
AV.100	A17 Signal Max	Selects the maximum Vdc voltage of the input for the 0-10 Vdc input mode.	Out of service Present Value	0 to 10V, Resolution: 0.5V
AV.103	A17 Temperature	In thermistor mode, it displays the actual temperature read by the 10K thermistor. In voltage or mA mode, it displays the temperature as set per the Temperature Min and Max parameters.	Out of service	-40 to 100°C or -40 to 212°F, Resolution: 0.01°C or 0.018°F
AV.104	A17 Temperature Min	In voltage or mA mode, it sets the minimum temperature range of the selected transmitter.	Out of service Present Value	-50 to 10°C or -58 to 50°F, Resolution: 0.5°C or 0.9°F
AV.105	A17 Temperature Max	In voltage or mA mode, it sets the maximum temperature range of the selected transmitter.	Out of service Present Value	40 to 125°C or 104 to 257°F, Resolution: 0.5°C or 0.9°F
AV.106	A17 Temperature Bias	In thermistor mode, it allows for a calibration offset of the input.	Out of service Present Value	-10 to 10°C or -18 to 18°F, Resolution: 0.01°C or 0.018°F
AV.109	A18 Signal Min	Select the minimum Vdc voltage of the input for the 0-10 Vdc input mode.	Out of service Present Value	0 to 10V, Resolution: 0.5V
AV.110	A18 Signal Max	Select the maximum Vdc voltage of the input for the 0-10 Vdc input mode.	Out of service Present Value	0 to 10V, Resolution: 0.5V
AV.113	A18 Temperature	In thermistor mode, it displays the actual temperature read by the 10K thermistor. In voltage or mA mode, it displays the temperature as set per the Temperature Min and Max parameters.	Out of service	-40 to 100°C or -40 to 212°F, Resolution: 0.01°C or 0.018°F
AV.114	A18 Temperature Min	In voltage or mA mode, it sets the minimum temperature range of the selected transmitter.	Out of service Present Value	-50 to 10°C or -58 to 50°F, Resolution: 0.5°C or 0.9°F



ID ¹	Name	Description	Writable?	Range
AV.115	AI8 Temperature Max	In voltage or mA mode, it sets the maximum temperature range of the selected transmitter.	Out of service Present Value	40 to 125°C or 104 to 257°F, Resolution: 0.5°C or 0.9°F
AV.116	AI8 Temperature Bias	In thermistor mode, it allows for a calibration offset of the input.	Out of service Present Value	-10 to 10°C or -18 to 18°F, Resolution: 0.01°C or 0.018°F
AV.125	Minimum Voltage AO1	Select the minimum Vdc voltage of the output for the 0-10 Vdc output.	Out of service Present Value	0 to 10V, Resolution: 0.01V
AV.126	Maximum Voltage AO1	Select the maximum Vdc voltage of the output for the 0-10 Vdc output.	Out of service Present Value	0 to 10V, Resolution: 0.01V
AV.127	AO1 Percentage	Command the analog output through arrays 1 to 16.	Out of service Present Value	0 to 100%, Resolution: 0.1%
AV.131	Minimum Voltage AO2	Select the minimum Vdc voltage of the output for the 0-10 Vdc output.	Out of service Present Value	0 to 10V, Resolution: 0.01V
AV.132	Maximum Voltage AO2	Select the maximum Vdc voltage of the output for the 0-10 Vdc output.	Out of service Present Value	0 to 10V, Resolution: 0.01V
AV.133	AO2 Percentage	Command the analog output through arrays 1 to 16.	Out of service Present Value	0 to 100%, Resolution: 0.1%
AV.137	Minimum Voltage AO3	Select the minimum Vdc voltage of the output for the 0-10 Vdc output.	Out of service Present Value	0 to 10V, Resolution: 0.01V
AV.138	Maximum Voltage AO3	Select the maximum Vdc voltage of the output for the 0-10 Vdc output.	Out of service Present Value	0 to 10V, Resolution: 0.01V
AV.139	AO3 Percentage	Command the analog output through arrays 1 to 16.	Out of service Present Value	0 to 100%, Resolution: 0.1%
AV.143	Minimum Voltage AO4	Select the minimum Vdc voltage of the output for the 0-10 Vdc output.	Out of service Present Value	0 to 10V, Resolution: 0.01V
AV.144	Maximum Voltage AO4	Select the maximum Vdc voltage of the output for the 0-10 Vdc output.	Out of service Present Value	0 to 10V, Resolution: 0.01V
AV.145	AO4 Percentage	Command the analog output through arrays 1 to 16.	Out of service Present Value	0 to 100%, Resolution: 0.1%
AV.150	Runtime	Displays the actual run time since the last power up in seconds.	Out of service	0 to 999999999, Resolution: 1
AV.158	Modbus TCP IP Keep Alive Time Out	Set the amount of time the Modbus communication stays open before connection is cut out, when no signal is received from the device.	Out of service Present Value	1 to 1440min, Resolution: 1min
AV.165	Binary Input 1 Pulse Count	Displays the number of pulses for the binary input.	Out of service	0 to 999999999, Resolution: 1
AV.166	Analog Input 1 Pulse Count	Displays the number of pulses for the analog input.	Out of service	0 to 999999999, Resolution: 1
AV.167	Analog Input 2 Pulse Count	Displays the number of pulses for the analog input.	Out of service	0 to 999999999, Resolution: 1
AV.168	Analog Input 3 Pulse Count	Displays the number of pulses for the analog input.	Out of service	0 to 999999999, Resolution: 1
AV.169	Analog Input 4 Pulse Count	Displays the number of pulses for the analog input.	Out of service	0 to 999999999, Resolution: 1
AV.170	Analog Input 5 Pulse Count	Displays the number of pulses for the analog input.	Out of service	0 to 999999999, Resolution: 1
AV.171	Analog Input 6 Pulse Count	Displays the number of pulses for the analog input.	Out of service	0 to 999999999, Resolution: 1
AV.172	Analog Input 7 Pulse Count	Displays the number of pulses for the analog input.	Out of service	0 to 999999999, Resolution: 1
AV.173	Analog Input 8 Pulse Count	Displays the number of pulses for the analog input.	Out of service	0 to 999999999, Resolution: 1
AV.174	Binary Input 2 Pulse Count	Displays the number of pulses for the binary input.	Out of service	0 to 999999999, Resolution: 1
AV.239	Network Timeout Delay	Set the network timeout delay.	Out of service Present Value	30 to 600 seconds, Resolution: 30 seconds
AV.241	Analog Output 1 Fail Safe Preset	Set the value of fail-safe preset for analog output 1.	Out of service Present Value	0 to 100%, Resolution: 0.1%
AV.242	Analog Output 2 Fail Safe Preset	Set the value of fail-safe preset for analog output 2.	Out of service Present Value	0 to 100%, Resolution: 0.1%
AV.243	Analog Output 3 Fail Safe Preset	Set the value of fail-safe preset for analog output 3.	Out of service Present Value	0 to 100%, Resolution: 0.1%
AV.244	Analog Output 4 Fail Safe Preset	Set the value of fail-safe preset for analog output 4.	Out of service Present Value	0 to 100%, Resolution: 0.1%



ID ¹	Name	Description	Writable?	Range
BI.1	Binary Input 1 Signal	Displays the status of the binary input.	Out of service	0= Open / 1= Close
BI.2	Binary Input 2 Signal	Displays the status of the binary input.	Out of service	0= Open / 1= Close
BO.1	Binary Output 1 Signal	Command the binary relays output through arrays 1 to 16.	Out of service Present Value	0= Open / 1= Close
BO.2	Binary Output 2 Signal	Command the binary relays output through arrays 1 to 16.	Out of service Present Value	0= Open / 1= Close
BO.3	Binary Output 3 Signal	Command the binary relays output through arrays 1 to 16.	Out of service Present Value	0= Open / 1= Close
BO.4	Binary Output 4 Signal	Commands the binary relays output through arrays 1 to 16.	Out of service Present Value	0= Open / 1= Close
BO.5	Binary Output 5 Signal	Command the binary relays output through arrays 1 to 16.	Out of service Present Value	0= Open / 1= Close
BO.6	Binary Output 6 Signal	Command the binary relays output through arrays 1 to 16.	Out of service Present Value	0= Open / 1= Close
BO.10	Alarm LED	Displays the status of the alarm LED.	Out of service	0= Off / 1=On
BO.11	Power LED	Displays the status of the power LED.	Out of service	0= Off / 1=On
BV.12	AI1 Binary	Displays the status of the analog input.	Out of service	0= Open / 1= Close
BV.13	AI2 Binary	Displays the status of the analog input.	Out of service	0= Open / 1= Close
BV.14	AI3 Binary	Displays the status of the analog input.	Out of service	0= Open / 1= Close
BV.15	AI4 Binary	Displays the status of the analog input.	Out of service	0= Open / 1= Close
BV.16	AI5 Binary	Displays the status of the analog input.	Out of service	0= Open / 1= Close
BV.17	AI6 Binary	Displays the status of the analog input.	Out of service	0= Open / 1= Close
BV.18	AI7 Binary	Displays the status of the analog input.	Out of service	0= Open / 1= Close
BV.19	AI8 Binary	Displays the status of the analog input.	Out of service	0= Open / 1= Close
BV.26	Ethernet enable	Select whether to enable or disable the Ethernet option.	Out of service Present Value	0= Disable / 1= Enable
BV.27	AO1 Binary	Override the status of the analog output when in Digital mode.	Out of service Present Value	0= Open / 1= Close
BV.28	AO1 Polarity	Select the polarity of the analog output.	Out of service Present Value	0= Direct / 1= Reverse
BV.29	Binary Input 1 Pulse Count Reset	Resets the value of binary input pulse counter	Out of service Present Value	0= No / 1= Yes
BV.30	Analog Input 1 Pulse Count Reset	Resets the value of analog input pulse counter	Out of service Present Value	0= No / 1= Yes
BV.31	Analog Input 2 Pulse Count Reset	Resets the value of analog input pulse counter	Out of service Present Value	0= No / 1= Yes
BV.32	Analog Input 3 Pulse Count Reset	Resets the value of analog input pulse counter	Out of service Present Value	0= No / 1= Yes
BV.33	Analog Input 4 Pulse Count Reset	Resets the value of analog input pulse counter	Out of service Present Value	0= No / 1= Yes
BV.34	Analog Input 5 Pulse Count Reset	Resets the value of analog input pulse counter	Out of service Present Value	0= No / 1= Yes
BV.35	Analog Input 6 Pulse Count Reset	Resets the value of analog input pulse counter	Out of service Present Value	0= No / 1= Yes
BV.36	Analog Input 7 Pulse Count Reset	Resets the value of analog input pulse counter	Out of service Present Value	0= No / 1= Yes
BV.37	Analog Input 8 Pulse Count Reset	Resets the value of analog input pulse counter	Out of service Present Value	0= No / 1= Yes
BV.38	Binary Input 2 Pulse Count Reset	Resets the value of binary input pulse counter	Out of service Present Value	0= No / 1= Yes
BV.39	AO2 Binary	Override the status of the analog output when in Digital mode.	Out of service Present Value	0= Open / 1= Close



ID ¹	Name	Description	Writable?	Range
BV.40	Inhibit Output Override	Select whether to prevent the manual override of outputs.	Out of service Present Value	0= Off / 1=On
BV.41	AO2 Polarity	Select the polarity of the analog output.	Out of service Present Value	0= Direct / 1= Reverse
BV.42	AO3 Binary	Override the status of the analog output when in Digital mode.	Out of service Present Value	0= Open / 1= Close
BV.43	AO3 Polarity	Select the polarity of the analog output.	Out of service Present Value	0= Direct / 1= Reverse
BV.44	AO4 Binary	Override the status of the analog output when in Digital mode.	Out of service Present Value	0= Open / 1= Close
BV.45	AO4 Polarity	Select the polarity of the analog output.	Out of service Present Value	0= Direct / 1= Reverse
BV.46	AI1 Polarity	Select the polarity of the analog input.	Out of service Present Value	0= Direct / 1= Reverse
BV.47	AI2 Polarity	Select the polarity of the analog input.	Out of service Present Value	0= Direct / 1= Reverse
BV.48	AI3 Polarity	Select the polarity of the analog input.	Out of service Present Value	0= Direct / 1= Reverse
BV.49	AI4 Polarity	Select the polarity of the analog input.	Out of service Present Value	0= Direct / 1= Reverse
BV.50	AI5 Polarity	Select the polarity of the analog input.	Out of service Present Value	0= Direct / 1= Reverse
BV.51	AI6 Polarity	Select the polarity of the analog input.	Out of service Present Value	0= Direct / 1= Reverse
BV.52	AI7 Polarity	Select the polarity of the analog input.	Out of service Present Value	0= Direct / 1= Reverse
BV.53	AI8 Polarity	Select the polarity of the analog input.	Out of service Present Value	0= Direct / 1= Reverse
BV.54	BI1 Polarity	Select the polarity of the binary input.	Out of service Present Value	0= Direct / 1= Reverse
BV.55	BI2 Polarity	Select the polarity of the binary input.	Out of service Present Value	0= Direct / 1= Reverse
BV.58	SMTP SSL	Select whether to use a secure socket layer encrypt the communication between the device and the email server or to use the default socket. If turned to <i>On</i> , SMTP Port value must be set to 587 and <i>SMTP Username</i> and <i>SMTP Password</i> settings must be filled out. If turned to <i>Off</i> , use SMTP Port 25 to use server without login account or SMTP Port 587 if login details for email account have been entered.	Out of service Present Value	0= Off / 1= On
BV.59	SMTP Port	Select the port number to be used for email transfer. If set to 25, server to server email transfer is enabled (can only be used if SMTP SSL is set to <i>Off</i>). If set to 587, client to server email transfer is enabled.	Out of service Present Value	0= 25 / 1= 587
BV.60	Notify Alarm	Select whether to get notified of all alarm messages by email.	Out of service Present Value	0= Off / 1= On
BV.61	Notify Warning	Select whether to get notified of all warning messages by email.	Out of service Present Value	0= Off / 1= On
BV.62	Notify App Msg	Select whether to get notified of all event messages by email.	Out of service Present Value	0= Off / 1= On
BV.68	Network Timeout Failsafe	Displays the network timeout fail-safe state.	Out of service	0 = Ok / 1 = Timeout
MSV.8	BACnet Server Language++	Local BACnet server language.	Out of service Present Value	1= English
MSV.9	BACnet Server List Mode	Local BACnet server object list level.	Out of service Present Value	1= Integrator 2= Advanced 3= Factory
MSV.10	BACnet Server Units	Configuration value to select the display units for the BACnet server	Out of service Present Value	1= Metric 2= Imperial



ID ¹	Name	Description	Writable?	Range
MSV.27	AI1 Signal Type	Select the input mode type operation. This setting should be the same as the jumper hardware configuration on the PCB.	Out of service Present Value	1= 0_10V 2= 4_20mA 3= 10K_TypeG 4= 10K_Type3A1 5= 10K_Type4A1 6= 10K_NTC 7= 20K_Type6A1 8= 30K_Type6A1 9= Digital_Input
MSV.28	AI2 Signal Type	Select the input mode type operation. This setting should be the same as the jumper hardware configuration on the PCB.	Out of service Present Value	1= 0_10V 2= 4_20mA 3= 10K_TypeG 4= 10K_Type3A1 5= 10K_Type4A1 6= 10K_NTC 7= 20K_Type6A1 8= 30K_Type6A1 9= Digital_Input
MSV.29	AI3 Signal Type	Select the input mode type operation. This setting should be the same as the jumper hardware configuration on the PCB.	Out of service Present Value	1= 0_10V 2= 4_20mA 3= 10K_TypeG 4= 10K_Type3A1 5= 10K_Type4A1 6= 10K_NTC 7= 20K_Type6A1 8= 30K_Type6A1 9= Digital_Input
MSV.30	AI4 Signal Type	Select the input mode type operation. This setting should be the same as the jumper hardware configuration on the PCB.	Out of service Present Value	1= 0_10V 2= 4_20mA 3= 10K_TypeG 4= 10K_Type3A1 5= 10K_Type4A1 6= 10K_NTC 7= 20K_Type6A1 8= 30K_Type6A1 9= Digital_Input
MSV.31	AI5 Signal Type	Select the input mode type operation. This setting should be the same as the jumper hardware configuration on the PCB.	Out of service Present Value	1= 0_10V 2= 4_20mA 3= 10K_TypeG 4= 10K_Type3A1 5= 10K_Type4A1 6= 10K_NTC 7= 20K_Type6A1 8= 30K_Type6A1 9= Digital_Input
MSV.32	AI6 Signal Type	Select the input mode type operation. This setting should be the same as the jumper hardware configuration on the PCB.	Out of service Present Value	1= 0_10V 2= 4_20mA 3= 10K_TypeG 4= 10K_Type3A1 5= 10K_Type4A1 6= 10K_NTC 7= 20K_Type6A1 8= 30K_Type6A1 9= Digital_Input
MSV.33	AI7 Signal Type	Select the input mode type operation. This setting should be the same as the jumper hardware configuration on the PCB.	Out of service Present Value	1= 0_10V 2= 4_20mA 3= 10K_TypeG 4= 10K_Type3A1 5= 10K_Type4A1 6= 10K_NTC 7= 20K_Type6A1 8= 30K_Type6A1 9= Digital_Input
MSV.34	AI8 Signal Type	Select the input mode type operation. This setting should be the same as the jumper hardware configuration on the PCB.	Out of service Present Value	1= 0_10V 2= 4_20mA 3= 10K_TypeG 4= 10K_Type3A1 5= 10K_Type4A1 6= 10K_NTC 7= 20K_Type6A1 8= 30K_Type6A1 9= Digital_Input



ID ¹	Name	Description	Writable?	Range
MSV.46	AO1 Mode	Select the mode for the analog output.	Out of service Present Value	1= Analog 2= Pulse 3= Digital
MSV.47	AO2 Mode	Select the mode for the analog output.	Out of service Present Value	1= Analog 2= Pulse 3= Digital
MSV.48	AO3 Mode	Select the mode for the analog output.	Out of service Present Value	1= Analog 2= Pulse 3= Digital
MSV.49	AO4 Mode	Select the mode for the analog output.	Out of service Present Value	1= Analog 2= Pulse 3= Digital
MSV.50	Binary Output 1 Fail Safe State	Select the fail-safe state for binary output 1.	Out of service Present Value	1= Last State 2= Open 3= Close
MSV.51	Binary Output 2 Fail Safe State	Select the fail-safe state for binary output 2.	Out of service Present Value	1= Last State 2= Open 3= Close
MSV.52	Binary Output 3 Fail Safe State	Select the fail-safe state for binary output 3.	Out of service Present Value	1= Last State 2= Open 3= Close
MSV.53	Binary Output 4 Fail Safe State	Select the fail-safe state for binary output 4.	Out of service Present Value	1= Last State 2= Open 3= Close
MSV.54	Binary Output 5 Fail Safe State	Select the fail-safe state for binary output 5.	Out of service Present Value	1= Last State 2= Open 3= Close
MSV.55	Binary Output 6 Fail Safe State	Select the fail-safe state for binary output 6.	Out of service Present Value	1= Last State 2= Open 3= Close
MSV.56	Analog Output 1 Fail Safe State	Select the fail-safe state for analog output 1.	Out of service Present Value	1= Last State 2= Preset
MSV.57	Analog Output 2 Fail Safe State	Select the fail-safe state for analog output 2.	Out of service Present Value	1= Last State 2= Preset
MSV.58	Analog Output 3 Fail Safe State	Select the fail-safe state for analog output 3.	Out of service Present Value	1= Last State 2= Preset
MSV.59	Analog Output 4 Fail Safe State	Select the fail-safe state for analog output 4.	Out of service Present Value	1= Last State 2= Preset
FIL.4	Sys Log Alarm	System Log Alarm file.		
FIL.5	USB System Log File	USB System Log file.		
FIL.6	USB System Alarm Log File	USB System Alarm Log file.		
FIL.16	System Log File	Current log file being archived and is sent to the SD card when file is full and a new one is started.		
CSV.10	HmiOverwrite	Overwrite the value displayed on the local display menu.	Present Value	
CSV.20	SMTP Server IP Address	Configure the server IP address for the email account.	Present Value	
CSV.21	SMTP Mail From	Set the email address that will be sending the notification messages.	Present Value	
CSV.22	SMTP Mail To	Set the email address that will be receiving the notification messages.	Present Value	
CSV.23	SMTP Username	Set the login username for the email account.	Present Value	
CSV.25	SMTP Password	Set the login password for the email account.	Present Value	
CSV.35	Ethernet Mac Add	Displays the local Ethernet MAC address.		

Modbus Registers

- Register address
 - As per protocol base (base 0); for PLC add 1 to protocol base.
 - As per holding register (base 400001)
- Functions:
 - 03 Read Holding Register
 - 06 Write Single Register
 - 16 Write Multiple Registers
- Error Codes:
 - 02 Illegal Data Address
 - 03 Illegal Value
 - 06 Slave Device Busy
- W = Writable register, RO = read only.
- No Real number in Modbus register, use scale to calculate real number. Register = Real number * Scale => Real number = Register / Scale. Scale could be 1, 10 or 100.
- When writing a register that contains a bit string, if the bit is writable (conditional or not), the write will always be accepted. If the bit is reserved or not writable, the write will be ignored and will keep its actual state.
- Use READ-MODIFY-WRITE sequence.

Protocol Base	Holding Register	Description	Data Type	Units/Values	Writable	Default Value
0	400001	Modbus Address and Product Type	Unsigned	MSB = Product type, not writable LSB = Modbus Address (1 to 247), writable	W	
1	400002	Device Baud Rate	Unsigned Scale 100	0, 9600, 19200, 38400, and 57600, 0 = Auto Baud Rate Detection Value/100 (e.g. 38400 baud = 384)	W	38400
2	400003	Modbus Slave Communication Port Configuration	Unsigned	0 = No parity, 2 Stop bits 1 = Even parity, 1 Stop bit 2 = Odd parity, 1 Stop bit	W	No parity, 2 Stops bits
3	400004	Product Name (characters 8 & 7)	ASCII	MSB = char 6, LSB = char 7	W	
4	400005	Product Name (characters 6 & 5)	ASCII	MSB = char 4, LSB = char 5	W	
5	400006	Product Name (characters 4 & 3)	ASCII	MSB = char 2, LSB = char 3	W	
6	400007	Product Name (characters 2 & 1)	ASCII	MSB = char 0, LSB = char 1	W	
7	400008	Product Actual Firmware Version	Unsigned	1 to 65535 (e.g. 100)	RO	
8	400009	Product Actual EEPROM Version	Unsigned	1 to 65535 (e.g. 100)	RO	

Protocol Base	Holding Register	Description	Data Type	Units/Values	Writable	Default Value
2000	402001	Analog Input 1 Signal		0-10V: Type: Unsigned, Scale:100, Unit: Volt, Range: 0.00-10.00V 4-20mA: Type: Unsigned, Scale:100, Unit: mA, Range: 4.00-20.00 mA, 10K Type G, 10K Type 3A1, 10K Type 4AI, 10K NTC, 20K Type 6AI, 30K Type 6AI: Type: Signed, Scale:100, Unit: °C, Range: -40.00 - 100.00 °C Type: Signed, Scale:100, Unit: °F, Range: -40.00 - 212.00 °F DI: Type: Unsigned, Scale:1, No Unit, Range: 0-1	RO	0
2001	402002	Analog Input 2 Signal				
2002	402003	Analog Input 3 Signal				
2003	402004	Analog Input 4 Signal				
2004	402005	Analog Input 5 Signal				
2005	402006	Analog Input 6 Signal				
2006	402007	Analog Input 7 Signal				
2007	402008	Analog Input 8 Signal				
4000	404001	Analog Output 1 Signal	Unsigned Scale 1000	Unit: Volt (V), Range: 0V to 10V, Value x 1000 (e.g. 3V = 3000)	W	0%
4001	404002	Analog Output 2 Signal		Unit: Volt (V), Range: 0V to 10V, Value x 1000 (e.g. 3V = 3000)	W	0%
4002	404003	Analog Output 3 Signal		Unit: Volt (V), Range: 0V to 10V, Value x 1000 (e.g. 3V = 3000)	W	0%
4003	404004	Analog Output 4 Signal		Unit: Volt (V), Range: 0V to 10V, Value x 1000 (e.g. 3V = 3000)	W	0%
6000	406001	AI1 Signal Min	Unsigned Scale 100	Unit: Volt (V), Range: 0V to 10V, Value x 100 (e.g. 2V = 200)	W	0V
6001	406002	AI1 Signal Max		Unit: Volt (V), Range: 0V to 10V, Value x 100 (e.g. 2V = 200)	W	10V
6002	406003	AI1 Temperature	Signed Scale 100	Unit: °C/°F, Range: -40°C to 100°C or -40°F to 212°F Value x 100 (e.g. 5°C = 500 or 10°F = 1000)	RO	0°C, 32°F
6003	406004	AI1 Temperature Min		Unit: °C/°F, Range: -50°C to 10°C or -58°F to 50°F Value x 100 (e.g. 5°C = 500 or 10°F = 1000)	W	-40°C, -40°F
6004	406005	AI1 Temperature Max		Unit: °C/°F, Range: 40°C to 125°C or 104°F to 257°F (Value x 100 (e.g. 50°C = 5000 or 105°F = 10500)	W	100°C, 212°F
6005	406006	AI1 Temperature Bias		Unit: °C/°F, Range: -10°C to 10°C or -18°F to 18°F Value x 100 (e.g. 5°C = 500 or 10°F = 1000)	W	0°C, 0°F
6006	406007	AI2 Signal Min	Unsigned Scale 100	Unit: Volt (V), Range: 0V to 10V, Value x 100 (e.g. 2V = 200)	W	0V
6007	406008	AI2 Signal Max		Unit: Volt (V), Range: 0V to 10V, Value x 100 (e.g. 2V = 200)	W	10V
6008	406009	AI2 Temperature	Signed Scale 100	Unit: °C/°F, Range: -40°C to 100°C or -40°F to 212°F Value x 100 (e.g. 5°C = 500 or 10°F = 1000)	RO	0°C, 32°F
6009	406010	AI2 Temperature Min		Unit: °C/°F, Range: -50°C to 10°C or -58°F to 50°F Value x 100 (e.g. 5°C = 500 or 10°F = 1000)	W	-40°C, -40°F
6010	406011	AI2 Temperature Max		Unit: °C/°F, Range: 40°C to 125°C or 104°F to 257°F (Value x 100 (e.g. 50°C = 5000 or 105°F = 10500)	W	100°C, 212°F
6011	406012	AI2 Temperature Bias		Unit: °C/°F, Range: -10°C to 10°C or -18°F to 18°F Value x 100 (e.g. 5°C = 500 or 10°F = 1000)	W	0°C, 0°F
6012	406013	AI3 Signal Min	Unsigned Scale 100	Unit: Volt (V), Range: 0V to 10V, Value x 100 (e.g. 2V = 200)	W	0V
6013	406014	AI3 Signal Max		Unit: Volt (V), Range: 0V to 10V, Value x 100 (e.g. 2V = 200)	W	10V
6014	406015	AI3 Temperature	Signed Scale 100	Unit: °C/°F, Range: -40°C to 100°C or -40°F to 212°F Value x 100 (e.g. 5°C = 500 or 10°F = 1000)	RO	0°C, 32°F

Protocol Base	Holding Register	Description	Data Type	Units/Values	Writable	Default Value
6015	406016	AI3 Temperature Min		Unit: °C/°F, Range: -50°C to 10°C or -58°F to 50°F Value x 100 (e.g. 5°C = 500 or 10°F = 1000)	W	-40°C, -40°F
6016	406017	AI3 Temperature Max		Unit: °C/°F, Range: 40°C to 125°C or 104°F to 257°F (Value x 100 (e.g. 50°C = 5000 or 105°F = 10500))	W	100°C, 212°F
6017	406018	AI3 Temperature Bias		Unit: °C/°F, Range: -10°C to 10°C or -18°F to 18°F Value x 100 (e.g. 5°C = 500 or 10°F = 1000)	W	0°C, 0°F
6018	406019	AI4 Signal Min	Unsigned Scale 100	Unit: Volt (V), Range: 0V to 10V, Value x 100 (e.g. 2V = 200)	W	0V
6019	406020	AI4 Signal Max		Unit: Volt (V), Range: 0V to 10V, Value x 100 (e.g. 2V = 200)	W	10V
6020	406021	AI4 Temperature	Signed Scale 100	Unit: °C/°F, Range: -40°C to 100°C or -40°F to 212°F Value x 100 (e.g. 5°C = 500 or 10°F = 1000)	RO	0°C, 32°F
6021	406022	AI4 Temperature Min		Unit: °C/°F, Range: -50°C to 10°C or -58°F to 50°F Value x 100 (e.g. 5°C = 500 or 10°F = 1000)	W	-40°C, -40°F
6022	406023	AI4 Temperature Max		Unit: °C/°F, Range: 40°C to 125°C or 104°F to 257°F (Value x 100 (e.g. 50°C = 5000 or 105°F = 10500))	W	100°C, 212°F
6023	406024	AI4 Temperature Bias		Unit: °C/°F, Range: -10°C to 10°C or -18°F to 18°F Value x 100 (e.g. 5°C = 500 or 10°F = 1000)	W	0°C, 0°F
6024	406025	AI5 Signal Min	Unsigned Scale 100	Unit: Volt (V), Range: 0V to 10V, Value x 100 (e.g. 2V = 200)	W	0V
6025	406026	AI5 Signal Max		Unit: Volt (V), Range: 0V to 10V, Value x 100 (e.g. 2V = 200)	W	10V
6026	406027	AI5 Temperature	Signed Scale 100	Unit: °C/°F, Range: -40°C to 100°C or -40°F to 212°F Value x 100 (e.g. 5°C = 500 or 10°F = 1000)	RO	0°C, 32°F
6027	406028	AI5 Temperature Min		Unit: °C/°F, Range: -50°C to 10°C or -58°F to 50°F Value x 100 (e.g. 5°C = 500 or 10°F = 1000)	W	-40°C, -40°F
6028	406029	AI5 Temperature Max		Unit: °C/°F, Range: 40°C to 125°C or 104°F to 257°F (Value x 100 (e.g. 50°C = 5000 or 105°F = 10500))	W	100°C, 212°F
6029	406030	AI5 Temperature Bias		Unit: °C/°F, Range: -10°C to 10°C or -18°F to 18°F Value x 100 (e.g. 5°C = 500 or 10°F = 1000)	W	0°C, 0°F
6030	406031	AI6 Signal Min	Unsigned Scale 100	Unit: Volt (V), Range: 0V to 10V, Value x 100 (e.g. 2V = 200)	W	0V
6031	406032	AI6 Signal Max		Unit: Volt (V), Range: 0V to 10V, Value x 100 (e.g. 2V = 200)	W	10V
6032	406033	AI6 Temperature	Signed Scale 100	Unit: °C/°F, Range: -40°C to 100°C or -40°F to 212°F Value x 100 (e.g. 5°C = 500 or 10°F = 1000)	RO	0°C, 32°F
6033	406034	AI6 Temperature Min		Unit: °C/°F, Range: -50°C to 10°C or -58°F to 50°F Value x 100 (e.g. 5°C = 500 or 10°F = 1000)	W	-40°C, -40°F
6034	406035	AI6 Temperature Max		Unit: °C/°F, Range: 40°C to 125°C or 104°F to 257°F (Value x 100 (e.g. 50°C = 5000 or 105°F = 10500))	W	100°C, 212°F
6035	406036	AI6 Temperature Bias		Unit: °C/°F, Range: -10°C to 10°C or -18°F to 18°F Value x 100 (e.g. 5°C = 500 or 10°F = 1000)	W	0 °C, 0°F
6036	406037	AI7 Signal Min	Unsigned Scale 100	Unit: Volt (V), Range: 0V to 10V, Value x 100 (e.g. 2V = 200)	W	0V
6037	406038	AI7 Signal Max		Unit: Volt (V), Range: 0V to 10V, Value x 100 (e.g. 2V = 200)	W	10V

Protocol Base	Holding Register	Description	Data Type	Units/Values	Writable	Default Value
6038	406039	AI7 Temperature	Signed Scale 100	Unit: °C/°F, Range: -40°C to 100°C or -40°F to 212°F Value x 100 (e.g. 5°C = 500 or 10°F = 1000)	RO	0°C, 32°F
6039	406040	AI7 Temperature Min		Unit: °C/°F, Range: -50°C to 10°C or -58°F to 50°F Value x 100 (e.g. 5°C = 500 or 10°F = 1000)	W	-40°C, -40°F
6040	406041	AI7 Temperature Max		Unit: °C/°F, Range: 40°C to 125°C or 104°F to 257°F (Value x 100 (e.g. 50°C = 5000 or 105°F = 10500))	W	100°C, 212°F
6041	406042	AI7 Temperature Bias		Unit: °C/°F, Range: -10°C to 10°C or -18°F to 18°F Value x 100 (e.g. 5°C = 500 or 10°F = 1000)	W	0°C, 0°F
6042	406043	AI8 Signal Min	Unsigned Scale 100	Unit: Volt (V), Range: 0V to 10V, Value x 100 (e.g. 2V = 200)	W	0V
6043	406044	AI8 Signal Max		Unit: Volt (V), Range: 0V to 10V, Value x 100 (e.g. 2V = 200)	W	10V
6044	406045	AI8 Temperature	Signed Scale 100	Unit: °C/°F, Range: -40°C to 100°C or -40°F to 212°F Value x 100 (e.g. 5°C = 500 or 10°F = 1000)	RO	0°C, 32 °F
6045	406046	AI8 Temperature Min		Unit: °C/°F, Range: -50°C to 10°C or -58°F to 50°F Value x 100 (e.g. 5°C = 500 or 10°F = 1000)	W	-40°C, -40°F
6046	406047	AI8 Temperature Max		Unit: °C/°F, Range: 40°C to 125°C or 104°F to 257°F (Value x 100 (e.g. 50°C = 5000 or 105°F = 10500))	W	100°C, 212°F
6047	406048	AI8 Temperature Bias		Unit: °C/°F, Range: -10°C to 10°C or -18°F to 18°F Value x 100 (e.g. 5°C = 500 or 10°F = 1000)	W	0°C, 0°F
6048	406049	Minimum Voltage AO1	Unsigned Scale 1000	Unit: Volt (V), Range: 0V to 10V, Value x 1000 (e.g. 3 V = 3000)	W	0V
6049	406050	Maximum Voltage AO1		Unit: Volt (V), Range: 0V to 10V, Value x 1000 (e.g. 3 V = 3000)	W	10V
6050	406051	AO1 Percentage	Unsigned Scale 10	Unit: %, Range: 0% to 100%, Value x 10 (e.g. 30% = 300)	W	0%
6051	406052	Minimum Voltage AO2	Unsigned Scale 1000	Unit: Volt (V), Range: 0V to 10V, Value x 1000 (e.g. 3 V = 3000)	W	0V
6052	406053	Maximum Voltage AO2		Unit: Volt (V), Range: 0V to 10V, Value x 1000 (e.g. 3 V = 3000)	W	10V
6053	406054	AO2 Percentage	Unsigned Scale 10	Unit: %, Range: 0% to 100%, Value x 10 (e.g. 30% = 300)	W	0%
6054	406055	Minimum Voltage AO3	Unsigned Scale 1000	Unit: Volt (V), Range: 0V to 10V, Value x 1000 (e.g. 3 V = 3000)	W	0V
6055	406056	Maximum Voltage AO3		Unit: Volt (V), Range: 0V to 10V, Value x 1000 (e.g. 3 V = 3000)	W	10V
6056	406057	AO3 Percentage	Unsigned Scale 10	Unit: %, Range: 0% to 100%, Value x 10 (e.g. 30% = 300)	W	0%
6057	406058	Minimum Voltage AO4	Unsigned Scale 1000	Unit: Volt (V), Range: 0V to 10V, Value x 1000 (e.g. 3 V = 3000)	W	0V
6058	406059	Maximum Voltage AO4		Unit: Volt (V), Range: 0V to 10V, Value x 1000 (e.g. 3 V = 3000)	W	10V
6059	406060	AO4 Percentage	Unsigned Scale 10	Unit: %, Range: 0% to 100%, Value x 10 (e.g. 30% = 300)	W	0%
6060	406061	Modbus TCP IP Keep Alive Time Out (0)	Unsigned Scale 1	Unit: Minutes (min), Range: 1 min to 1440 min Value x 1 (e.g. 100 min = 100)	W	5 min
6061	406062	Modbus TCP IP Keep Alive Time Out (1)				

Protocol Base	Holding Register	Description	Data Type	Units/Values	Writable	Default Value
6062	406063	Binary Input 1 Pulse Count (0)	Unsigned Scale 1	No Unit, Range: 0 to 999999999 Value x 1 (e.g. 100 = 100)	RO	0
6063	406064	Binary Input 1 Pulse Count (1)			RO	
6064	406065	Binary Input 1 Pulse Count (2)			RO	
6065	406066	Binary Input 1 Pulse Count (3)			RO	
6066	406067	Analog Input 1 Pulse Count (0)	Unsigned Scale 1	No Unit, Range: 0 to 999999999 Value x 1 (e.g. 100 = 100)	RO	0
6067	406068	Analog Input 1 Pulse Count (1)			RO	
6068	406069	Analog Input 1 Pulse Count (2)			RO	
6069	406070	Analog Input 1 Pulse Count (3)			RO	
6070	406071	Analog Input 2 Pulse Count (0)	Unsigned Scale 1	No Unit, Range: 0 to 999999999 Value x 1 (e.g. 100 = 100)	RO	0
6071	406072	Analog Input 2 Pulse Count (1)			RO	
6072	406073	Analog Input 2 Pulse Count (2)			RO	
6073	406074	Analog Input 2 Pulse Count (3)			RO	
6074	406075	Analog Input 3 Pulse Count (0)	Unsigned Scale 1	No Unit, Range: 0 to 999999999 Value x 1 (e.g. 100 = 100)	RO	0
6075	406076	Analog Input 3 Pulse Count (1)			RO	
6076	406077	Analog Input 3 Pulse Count (2)			RO	
6077	406078	Analog Input 3 Pulse Count (3)			RO	
6078	406079	Analog Input 4 Pulse Count (0)	Unsigned Scale 1	No Unit, Range: 0 to 999999999 Value x 1 (e.g. 100 = 100)	RO	0
6079	406080	Analog Input 4 Pulse Count (1)			RO	
6080	406081	Analog Input 4 Pulse Count (2)			RO	
6081	406082	Analog Input 4 Pulse Count (3)			RO	
6082	406083	Analog Input 5 Pulse Count (0)	Unsigned Scale 1	No Unit, Range: 0 to 999999999 Value x 1 (e.g. 100 = 100)	RO	0
6083	406084	Analog Input 5 Pulse Count (1)			RO	
6084	406085	Analog Input 5 Pulse Count (2)			RO	
6085	406086	Analog Input 5 Pulse Count (3)			RO	
6086	406087	Analog Input 6 Pulse Count (0)	Unsigned Scale 1	No Unit, Range: 0 to 999999999 Value x 1 (e.g. 100 = 100)	RO	0
6087	406088	Analog Input 6 Pulse Count (1)			RO	
6088	406089	Analog Input 6 Pulse Count (2)			RO	
6089	406090	Analog Input 6 Pulse Count (3)			RO	

Protocol Base	Holding Register	Description	Data Type	Units/Values	Writable	Default Value
6090	406091	Analog Input 7 Pulse Count (0)	Unsigned Scale 1	No Unit, Range: 0 to 999999999 Value x 1 (e.g. 100 = 100)	RO	0
6091	406092	Analog Input 7 Pulse Count (1)			RO	
6092	406093	Analog Input 7 Pulse Count (2)			RO	
6093	406094	Analog Input 7 Pulse Count (3)			RO	
6094	406095	Analog Input 8 Pulse Count (0)	Unsigned Scale 1	No Unit, Range: 0 to 999999999 Value x 1 (e.g. 100 = 100)	RO	0
6095	406096	Analog Input 8 Pulse Count (1)			RO	
6096	406097	Analog Input 8 Pulse Count (2)			RO	
6097	406098	Analog Input 8 Pulse Count (3)			RO	
6098	406099	Binary Input 2 Pulse Count (0)	Unsigned Scale 1	No Unit, Range: 0 to 999999999 Value x 1 (e.g. 100 = 100)	RO	0
6099	406100	Binary Input 2 Pulse Count (1)			RO	
6100	406101	Binary Input 2 Pulse Count (2)			RO	
6101	406102	Binary Input 2 Pulse Count (3)			RO	
6102	406103	Network Timeout Delay (0)	Unsigned Scale 1	Unit: Seconds (sec), Range: 30 sec to 600 sec Value x 1 (e.g. 1 sec = 1)	W	60 sec
6103	406104	Network Timeout Delay (1)				
6104	406105	Analog Output 1 Fail Safe Preset (0)	Unsigned Scale 10	Unit: %, Range: 0% to 100%, Value x 10 (e.g. 30% = 300)	W	0%
6105	406106	Analog Output 1 Fail Safe Preset (1)				
6106	406107	Analog Output 2 Fail Safe Preset (0)	Unsigned Scale 10	Unit: %, Range: 0% to 100%, Value x 10 (e.g. 30% = 300)	W	0%
6107	406108	Analog Output 2 Fail Safe Preset (1)				
6108	406109	Analog Output 3 Fail Safe Preset (0)	Unsigned Scale 10	Unit: %, Range: 0% to 100%, Value x 10 (e.g. 30% = 300)	W	0%
6109	406110	Analog Output 3 Fail Safe Preset (1)				
6110	406111	Analog Output 4 Fail Safe Preset (0)	Unsigned Scale 10	Unit: %, Range: 0% to 100%, Value x 10 (e.g. 30% = 300)	W	0%
6111	406112	Analog Output 4 Fail Safe Preset (1)				
10000	410001	Binary Input 1 Signal	Unsigned	0= Open 1= Close	RO	0
10001	410002	Binary Input 2 Signal	Unsigned	0= Open 1= Close	RO	0
11000	411001	Binary Output 1 Signal	Unsigned	0= Open 1= Close	W	0
11001	411002	Binary Output 2 Signal	Unsigned	0= Open 1= Close	W	0
11002	411003	Binary Output 3 Signal	Unsigned	0= Open 1= Close	W	0
11003	411004	Binary Output 4 Signal	Unsigned	0= Open 1= Close	W	0

Protocol Base	Holding Register	Description	Data Type	Units/Values	Writable	Default Value
11004	411005	Binary Output 5 Signal	Unsigned	0= Open 1= Close	W	0
11005	411006	Binary Output 6 Signal	Unsigned	0= Open 1= Close	W	0
11006	411007	Alarm LED	Unsigned	0= Off 1= On	RO	0
11007	411008	Power LED	Unsigned	0= Off 1= On	RO	0
12000	412001	AI1 Binary	Unsigned	0= Open 1= Close	RO	0
12001	412002	AI2 Binary	Unsigned	0= Open 1= Close	RO	0
12002	412003	AI3 Binary	Unsigned	0= Open 1= Close	RO	0
12003	412004	AI4 Binary	Unsigned	0= Open 1= Close	RO	0
12004	412005	AI5 Binary	Unsigned	0= Open 1= Close	RO	0
12005	412006	AI6 Binary	Unsigned	0= Open 1= Close	RO	0
12006	412007	AI7 Binary	Unsigned	0= Open 1= Close	RO	0
12007	412008	AI8 Binary	Unsigned	0= Open 1= Close	RO	0
12008	412009	AO1 Binary	Unsigned	0= Open 1= Close	W	0
12009	412010	AO1 Polarity	Unsigned	0= Direct 1= Reverse	W	0
12010	412011	Binary Input 1 Pulse Count Reset	Unsigned	0= No 1= Yes	W	0
12011	412012	Analog Input 1 Pulse Count Reset	Unsigned	0= No 1= Yes	W	0
12012	412013	Analog Input 2 Pulse Count Reset	Unsigned	0= No 1= Yes	W	0
12013	412014	Analog Input 3 Pulse Count Reset	Unsigned	0= No 1= Yes	W	0
12014	412015	Analog Input 4 Pulse Count Reset	Unsigned	0= No 1= Yes	W	0
12015	412016	Analog Input 5 Pulse Count Reset	Unsigned	0= No 1= Yes	W	0
12016	412017	Analog Input 6 Pulse Count Reset	Unsigned	0= No 1= Yes	W	0
12017	412018	Analog Input 7 Pulse Count Reset	Unsigned	0= No 1= Yes	W	0
12018	412019	Analog Input 8 Pulse Count Reset	Unsigned	0= No 1= Yes	W	0
12019	412020	Binary Input 2 Pulse Count Reset	Unsigned	0= No 1= Yes	W	0
12020	412021	AO2 Binary	Unsigned	0= Open 1= Close	W	0
12021	412022	AO2 Polarity	Unsigned	0= Direct 1= Reverse	W	0
12022	412023	AO3 Binary	Unsigned	0= Open 1= Close	W	0
12023	412024	AO3 Polarity	Unsigned	0= Direct 1= Reverse	W	0
12024	412025	AO4 Binary	Unsigned	0= Open 1= Close	W	0

Protocol Base	Holding Register	Description	Data Type	Units/Values	Writable	Default Value
12025	412026	AO4 Polarity	Unsigned	0= Direct 1= Reverse	W	0
12026	412027	AI1 Polarity	Unsigned	0= Direct 1= Reverse	W	0
12027	412028	AI2 Polarity	Unsigned	0= Direct 1= Reverse	W	0
12028	412029	AI3 Polarity	Unsigned	0= Direct 1= Reverse	W	0
12029	412030	AI4 Polarity	Unsigned	0= Direct 1= Reverse	W	0
12030	412031	AI5 Polarity	Unsigned	0= Direct 1= Reverse	W	0
12031	412032	AI6 Polarity	Unsigned	0= Direct 1= Reverse	W	0
12032	412033	AI7 Polarity	Unsigned	0= Direct 1= Reverse	W	0
12033	412034	AI8 Polarity	Unsigned	0= Direct 1= Reverse	W	0
12034	412035	BI1 Polarity	Unsigned	0= Direct 1= Reverse	W	0
12035	412036	BI2 Polarity	Unsigned	0= Direct 1= Reverse	W	0
12036	412037	Notify Alarm	Unsigned	0= Off 1= On	W	0
12037	412038	Notify Warning	Unsigned	0= Off 1= On	W	0
12038	412039	Notify App Msg	Unsigned	0= Off 1= On	W	0
12039	412040	Network Timeout Failsafe	Unsigned	0= Ok 1= Timeout	RO	0
15000	415001	Modbus Server Units	Unsigned	0 = Metric 1 = Imperial	W	0
15001	415002	AI1 Signal Type	Unsigned	0= 0_10V 1= 4_20mA 2= 10K_TypeG 3= 10K_Type3A1 4= 10K_Type4A1 5= 10K_NTC 6= 20K_Type6A1 7= 30K_Type6A1 8= Digital_Input	W	2
15002	415003	AI2 Signal Type	Unsigned	0= 0_10V 1= 4_20mA 2= 10K_TypeG 3= 10K_Type3A1 4= 10K_Type4A1 5= 10K_NTC 6= 20K_Type6A1 7= 30K_Type6A1 8= Digital_Input	W	2
15003	415004	AI3 Signal Type	Unsigned	0= 0_10V 1= 4_20mA 2= 10K_TypeG 3= 10K_Type3A1 4= 10K_Type4A1 5= 10K_NTC 6= 20K_Type6A1 7= 30K_Type6A1 8= Digital_Input	W	2
15004	415005	AI4 Signal Type	Unsigned	0= 0_10V 1= 4_20mA 2= 10K_TypeG 3= 10K_Type3A1 4= 10K_Type4A1 5= 10K_NTC 6= 20K_Type6A1 7= 30K_Type6A1 8= Digital_Input	W	2

Protocol Base	Holding Register	Description	Data Type	Units/Values	Writable	Default Value
15005	415006	AI5 Signal Type	Unsigned	0= 0_10V 1= 4_20mA 2= 10K_TypeG 3= 10K_Type3A1 4= 10K_Type4A1 5= 10K_NTC 6= 20K_Type6A1 7= 30K_Type6A1 8= Digital_Input	W	2
15006	415007	AI6 Signal Type	Unsigned	0= 0_10V 1= 4_20mA 2= 10K_TypeG 3= 10K_Type3A1 4= 10K_Type4A1 5= 10K_NTC 6= 20K_Type6A1 7= 30K_Type6A1 8= Digital_Input	W	2
15007	415008	AI7 Signal Type	Unsigned	0= 0_10V 1= 4_20mA 2= 10K_TypeG 3= 10K_Type3A1 4= 10K_Type4A1 5= 10K_NTC 6= 20K_Type6A1 7= 30K_Type6A1 8= Digital_Input	W	2
15008	415009	AI8 Signal Type	Unsigned	0= 0_10V 1= 4_20mA 2= 10K_TypeG 3= 10K_Type3A1 4= 10K_Type4A1 5= 10K_NTC 6= 20K_Type6A1 7= 30K_Type6A1 8= Digital_Input	W	2
15009	415010	AO1 Mode	Unsigned	0= Analog 1= Pulsed 2= Digital	W	0
15010	415011	AO2 Mode	Unsigned	0= Analog 1= Pulsed 2= Digital	W	0
15011	415012	AO3 Mode	Unsigned	0= Analog 1= Pulsed 2= Digital	W	0
15012	415013	AO4 Mode	Unsigned	0= Analog 1= Pulsed 2= Digital	W	0
15013	415014	Binary Output 1 Fail Safe State	Unsigned	0= Last State 1= Open 2= Close	W	0
15014	415015	Binary Output 2 Fail Safe State	Unsigned	0= Last State 1= Open 2= Close	W	0
15015	415016	Binary Output 3 Fail Safe State	Unsigned	0= Last State 1= Open 2= Close	W	0
15016	415017	Binary Output 4 Fail Safe State	Unsigned	0= Last State 1= Open 2= Close	W	0

Protocol Base	Holding Register	Description	Data Type	Units/Values	Writable	Default Value
15017	415018	Binary Output 5 Fail Safe State	Unsigned	0= Last State 1= Open 2= Close	W	0
15018	415019	Binary Output 6 Fail Safe State	Unsigned	0= Last State 1= Open 2= Close	W	0
15019	415020	Analog Output 1 Fail Safe State	Unsigned	0= Last State 1= Preset	W	0
15020	415021	Analog Output 2 Fail Safe State	Unsigned	0= Last State 1= Preset	W	0
15021	415022	Analog Output 3 Fail Safe State	Unsigned	0= Last State 1= Preset	W	0
15022	415023	Analog Output 4 Fail Safe State	Unsigned	0= Last State 1= Preset	W	0





Recycling at end of life: please return this product to your Neptronic local distributor for recycling. If you need to find the nearest Neptronic authorized distributor, please consult www.neptronic.com.



neptronic[®]

400 Lebeau blvd, Montreal, Qc, H4N 1R6, Canada

www.neptronic.com

Toll free in North America: 1-800-361-2308

Tel.: (514) 333-1433

Fax: (514) 333-3163

Customer service fax: (514) 333-1091

Monday to Friday: 8:00am to 5:00pm (Eastern time)